

ICR-3211B

INDUSTRIAL IoT LTE Cat M1 & NB-IoT ROUTER & GATEWAY



- + Industrial IoT LPWAN Gateway
- + Global LTE Cat.M1 & NB-IoT coverage with GSM fallback
- + Powerful CPU with 1.3 GB storage to host customer SW applications
- + 2x SIM with cover, eSIM ready
- + 2x Ethernet 10/100, 1x RS232, 1x RS485 and I/O
- + Robust metal cover with DIN and Wall mount options
- + Operational temperature range from -40 °C to +75 °C
- + Backup real time clock
- + Sleep mode & Power ignition
- + Last-gasp Supercapacitor

ICR-3211B is an industrial cellular gateway intended for the North American (NAM) and European (EMEA) markets. The ICR-3211B router is designed for wireless communication in the mobile networks that make use of traditional cellular technologies. The primary purpose of this router is its use in the Category M1 (LTE-M) as well as Narrowband Internet of Things (NB-IoT) services on the cellular LTE network.

LTE Cat M1 is a new cellular technology specifically designed for the needs of applications targeting the Internet of Things (IoT) or machine-to-machine (M2M) communications. LTE Cat M1 is a low-power wide-area (LPWA) air interface that lets you connect IoT and M2M devices with medium data rate requirements (375 kbps upload and download speeds in half duplex mode).

In addition to its two independent or switched Ethernet ports, serial ports RS232 and RS485, ICR-3211B has built-in digital I/O connectivity, backup real-time clock and sleep mode support. The device has two SIM readers protected by metallic cover for carrier failover redundancy. As an addition the router is ready to use internal eSIM.

The Last-gasp supercapacitor ensures safe sending out of information about power failure or send last processed data.

The router supports VPN tunnel creation using various protocols to ensure safe communications. The router provides diagnostic functions which include automatic monitoring of the wireless and wired connections, automatic restart in case of connection losses, and a hardware watchdog that monitors the router status.

The ICR-3211B places intelligence at the network edge with an extremely powerful Cortex A8 CPU at 1GHz, 512 MB RAM and 4 GB EMMC FLASH memory in pSLC mode for a long-lifetime and critical industrial applications. 1.3 GB of memory space is allocated for customer SW applications and data. With open Linux platform and wide possibilities of programming customer SW applications in Python, C/C++ or browser-based flow editor Node-RED the ICR-3211B offers a real open development platform for Industrial IoT applications.

The Advantech existing app library (User modules) with apps already developed to enhance specific router functionality including industrial protocol conversions and support of IoT platforms such as MS Azure, Cumulocity, ThingWorx and others are supported on the router.

ICR-3211B is easy to install using WebAccess/DMP, a full featured configuration and monitoring tool for mass deployment. The router also supports additional traffic and health monitoring software R-SeeNet.



ORDERING INFORMATION – Antennas & Power Supplies Sold Separately

MODEL NO. - ORDER CODES	REGION	2x ETHERNET	RS232 RS485	I/O	LTE ANT	2x SIM	LAST-GASP
 ICR-3211B	NAM EMEA	✓	✓	✓	✓	✓	✓



ACCESSORIES - INCLUDED

DESCRIPTION	
Wall mount kit	
DIN clip	BB-DIN-ICR32
Serial / IO connector	BB-CON-ICR32-10
PWR connector	BB-CON-WR2
Quick Start Guide	

ACCESSORIES - SOLD SEPARATELY

ORDER CODE	DESCRIPTION
BB-GA.110.101111	Antenna LTE, Magnet Mount
BB-TG.10.0113	Antenna LTE, Terminal
BB-RPS-v2-WR2-US	Wall mount Power Supply 12V/1A, US plug

SPECIFICATIONS

NETWORKING	
Network and Routing	DHCP Server, NAT/PAT, VRRP, Dynamic DNS client, DNS proxy, VLAN, QoS, DMVPN, NTP Client/ Server, IGMP, BGP, OSPF, RIP, SMTP, SMTPS, SNMP v1/ v2c/ v3, Backup Routers, PPP, PPPoE, SSL, Port Forwarding, Host Port Routing, Ethernet Bridging, Load Balancing, IPv6 Dual Stack
Security	HTTPS, SSH, VPN tunnels, SFTP, DMZ, Firewall (IP Filtering, MAC address filtering, Inbound and outbound Port filtering)
VPN Tunnelling	Open VPN client and server and P2P, L2TP, PPTP, GRE, EasyVPN, IPsec with IKEv1 and IKEv2
Configuration	Webserver, SSH, Four configuration switchable profiles, Automatic configuration update from server, Backup configuration, Restore configuration
Firmware Management	Automatic firmware updates from the server, locally via LAN or remotely via WAN (HTTP, HTTPS), Over-the-Air cellular module firmware updates
Diagnostic	One CLICK report - current configuration / factory identification / system log / kernel log / reboot log / routing table, Remote diagnostics possible via SSH
Status	Network Status, DHCP Status, IPsec Status, Statistics history for last 60days
Log	System Log, Reboot Log, Kernel Log
Controlling and Diagnostic	SMS, SNMP v1/v2c/v3, Statuses
Event Engine	StartUp script & Up/Down script (Bash, Python), Digital Input, Network Parameters, Data Usage, Timer, Power, Device Temperature. Report Types: SMS, email, SNMP Trap
Industrial Protocols	Modbus RTU/TCP gateway, IEC 60870-5-101 to 104 gateway, DF1, DNP3
Applications Development	Open Linux, Python, BASH, C/C++, Node-RED

PORTS, LED, ANTENNAS	
2x Ethernet	RJ45, 10/100 Mbps
2x SIM	Mini SIMs (2FF)
LED indicators	PWR, SIGNAL, DAT, SIM1, SIM2, USR, ETH
1x ANT	SMA connectors
1x RS232, 1x RS485	(10-Way Terminal block)
I/O	1x Digital Input (On Voltage: 2.7V to 36VDC) 1x Binary Output (10-Way Terminal block)

CPU, MEMORY	
CPU	Cortex-A8, 1000 MHz
RAM	512 MB
Flash memory	eMMC - 4096 MB (838 MB for Router Apps, 512 MB for customer data)

MECHANICAL	
Metal case, Metal DIN rail, Wall mount kit	Metal
Enclosure Dimensions	31.2 x 94 x 129 mm
Weight	457 g

CELLULAR MODULE PARAMETERS	
LTE parameters	LTE: Cat M1 / Cat NB1 FDD frequencies: B12, B13, B28 (700 MHz), B20 (800 MHz), B5, B18, B19, B26 (850 MHz), B8 (900 MHz), B4 (1700 MHz), B3 (1800 MHz), B2 (1900 MHz), B1 (2100 MHz) TDD frequencies: B39 (1900 MHz) Cat M1 only LTE bit rates: 375 Kbps (DL) / 375 Kbps (UL)
EDGE parameters	Supported frequencies: 850 MHz, 900 MHz, 1800 MHz, 1900 MHz EDGE bit rates: 296 Kbps (DL) / 236.8 Kbps (UL)
GPRS parameters	Supported frequencies: 850 MHz, 900 MHz, 1800 MHz, 1900 MHz GPRS bit rates: 107 Kbps (DL) / 85.6 Kbps (UL)



SPECIFICATIONS - CONTINUED

POWER, CONSUMPTION, ENVIRONMENTAL, IP COVER

Power Supply	9 – 36VDC (2-Way Terminal block)
Power Consumption - Idle / Average / Peak / Sleep Mode	2.5 / 4 W / 11 W / 0.085 W
Temperature Range – Operating / Storage	-40 to +75 °C / -40 to +85 °C
Humidity – Operating / Storage (noncondensing)	0 to 95 % / 0 to 95 %
Cold Start	-40 °C
Operating Altitude	2000 m / 70 kPa
Enclosure Rating	IP30
Grounding screw	

STANDARDS AND REGULATIONS

Radio	PTCRB, EN 301 511, EN 301 908-1, EN 301 908-13, EN 303 413
EMC	EN301 489-1, EN301 489-19, EN301 489-52, EN61000-6-2, EN61000-6-4, FCC 15.107 Class B, FCC 15.109 Class B, IC
Safety	EN 60 950-1:2006 + A11:2009 + A1:2010 + A12:2011 + A2:2013 + AC:2011
Transportation	EN 45545-2
Carrier approvals	Verizon, AT&T
National	FCC, IC, CE compliant
Environmental	REACH, RoHS and WEEE compliant

ICR-3211B

INDUSTRIAL IoT LTE Cat M1 & NB-IoT ROUTER & GATEWAY



MECHANICAL DRAWING

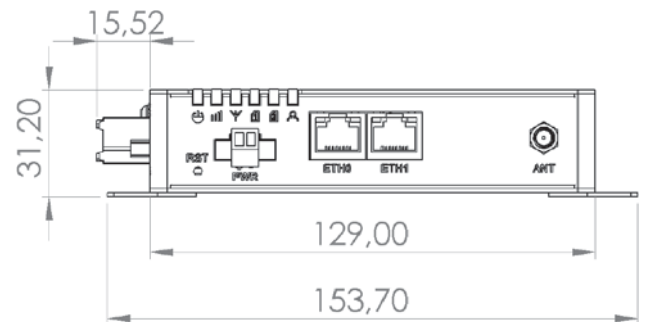
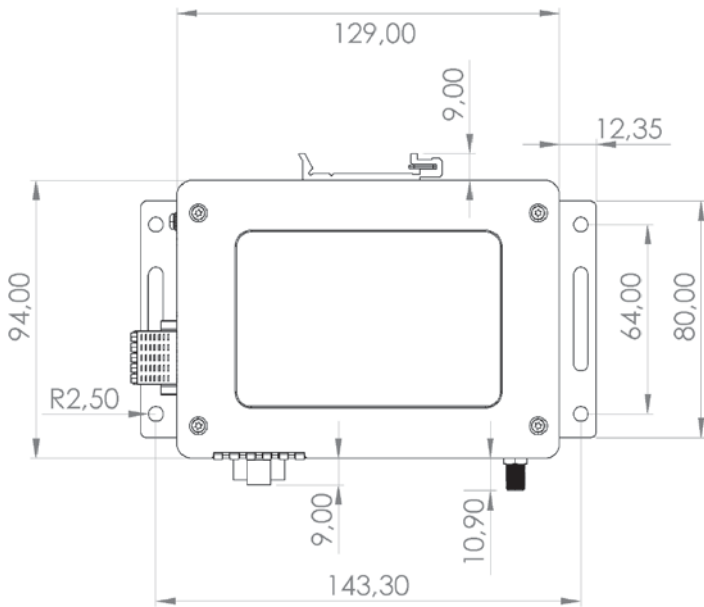

FRONT VIEW

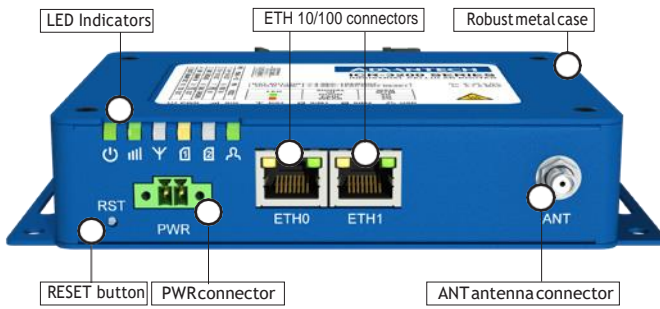

REAR VIEW

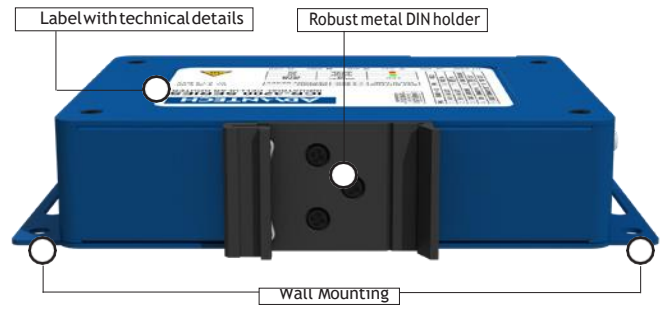

LEFT SIDE VIEW

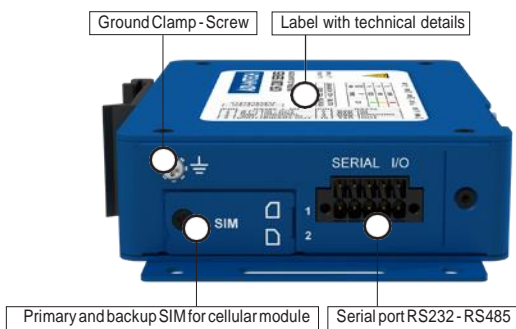

RIGHT SIDE VIEW



ICR-3211B

INDUSTRIAL IoT LTE Cat M1 & NB-IoT ROUTER & GATEWAY