

EKI-5526/I-EI EKI-5528/I-EI

16 port Entry-Level Managed Switch Supporting EtherNet/IP
8 port Entry-Level Managed Switch Supporting EtherNet/IP



Features

- ③ 16 ports Fast Ethernet RJ-45 (EKI-5526/I-EI) & 8 ports Fast Ethernet RJ-45 (EKI-5528/I-EI)
- ③ Entry-Level Managed Switch
- ③ IXM function enables fast deployment
- ③ Provides EtherNet/IP EDS (Electronic Data Sheet) file, AOI (Add On Instructions) file, and FactoryTalk® View faceplate
- ③ Management: SNMP v1/v2c/v3, WEB, Standard MIB, Private MIB



Introduction

The EKI-5526/I-EI and EKI-5528/I-EI are a new generation of entry-level managed switch products. They support the EtherNet/IP protocol to communicate with EtherNet/IP based PLCs. Advantech also provides the FactoryTalk® View compliant faceplate, so users can easily integrate the switch with Allen-Bradley® PLCs. "Electronic Data Sheet" (EDS files) are also available for users to customize faceplate. The devices come with a compact metal housing that is IP30 rated to protect against dusty industrial environments. The wide power input power (8.4 to 52.8 VDC) is dedicated to operating in areas of unstable power and rugged environments.

Specifications

Communications

- ③ **Standard** IEEE 802.3, 802.3u, 802.3x, 802.1D, 802.1w, 802.1p, 802.1Q, 802.1X, 802.3AD, 802.3az
- ③ **LAN** 10/100Base-T (X),
- ③ **Transmission Distance** Ethernet: Up to 100 m
- ③ **Transmission Speed Ethernet** 10/100Mbps Auto-Negotiation

Interface

- ③ **I/O Port** EKI-5526/I-EI: 16 x RJ-45
EKI-5528/I-EI: 8 x RJ-45
- ③ **Power Connector** 6-pin screw Terminal Block (including relay)

Physical

- ③ **Enclosure** Metal Shell
- ③ **Protection Class** IP 30
- ③ **Installation** DIN-Rail
- ③ **Dimensions (W x H x D)** EKI-5526/I-EI: 74 x 120 x 84 mm
EKI-5528/I-EI: 43 x 120 x 84 mm

LED Display

- ③ **System LED** PWR1, PWR2, P-Activity
- ③ **Port LED** Link / Speed /

Environment

- ③ **Operating Temperature** EKI-5526-I-EI & EKI-5528-I-EI: -40 ~ 75°C (-40 ~ 167°F)
EKI-5526-EI & EKI-5528-EI: -10 ~ 60°C (14 ~ 140°F)
- ③ **Storage Temperature** -40 ~ 85°C
- ③ **Ambient Relative Humidity** 10 ~ 95% (non-condensing)

- ③ 95% (non-condensing)
- ③ **MTBF**

Humidity 10 ~ 95% (non-condensing)
EKI-5528/I-EI: 4,176,861 hours
EKI-5526/I-EI: 2,788,343 hours

Power

- ③ Max. 8W
- ③ EKI-5526/I-EI:
EKI-5528/I-EI: Max. 5.2 W
- ③ **Power Input** 12~48V_{DC}(8.4~52.8V_{DC}),
redundant dual power input
- ③ **Fault Output** 1 Relay Output

Certification

- ③ **EMI CE**, FCC Class A
- ③ **Safety** UL508, Class 1 Division 2,
ATEX
- ③ **EMC** EN 61000-4-2; EN 61000-4-3; EN 61000-4-4;
EN 61000-4-5; EN 61000-4-6; EN 61000-4-8
IEC 60068-2-27
- ③ **Shock**
- ③ **Freefall** IEC 60068-2-32
- ③ **Vibration** IEC 60068-2-6

L2 Features

- ③ **L2 MAC Address** 8K
- ③ **Jumbo Frame** 9216 Bytes
- ③ **VLAN Group** 256 (VLAN ID 1~4094)

③

③

③

③

unicast

③

MSTP, IEEE

QoS

- ③ **Priority Queue** WRR (Weighted Round Robin), SP
(Strict Scheduling
Scheduling Priority) Hybrid Priority
- ③ **Class of Service** IEEE 802.1p Based CoS,
IP TOS, DSCP based CoS
- ③ **Rate Limiting** Ingress Rate limit, Egress Rate
limit
- ③ **Link Aggregation** IEEE 802.3ad Dynamic
Port Trunking, Static Port
Trunking

VLAN Arrange Port based VLAN, GVRP

Port Mirroring Per port, Multi-source port,

IP Multicast IGMP

Snooping v1/v2/v3, MLD

Snooping, IGMP Immediate leave

Storm Control Broadcast, Multicast, Unknown

Redundancy IEEE 802.1D-STP, IEEE 802.1s-

802.1w-RSTP, X-Ring, with ultra high-speed recovery
time less than 20ms

Dimensions

Unit: mm[inch]

EKI-5526/I-EI

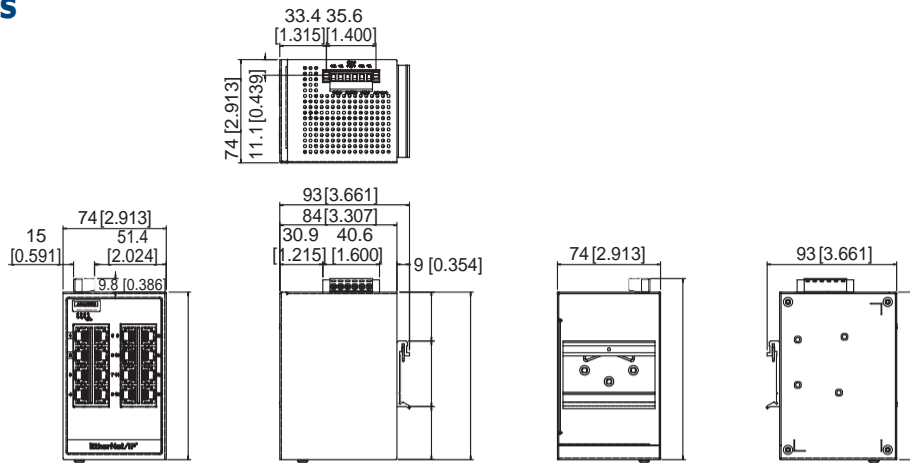

EKI-5528/I-EI

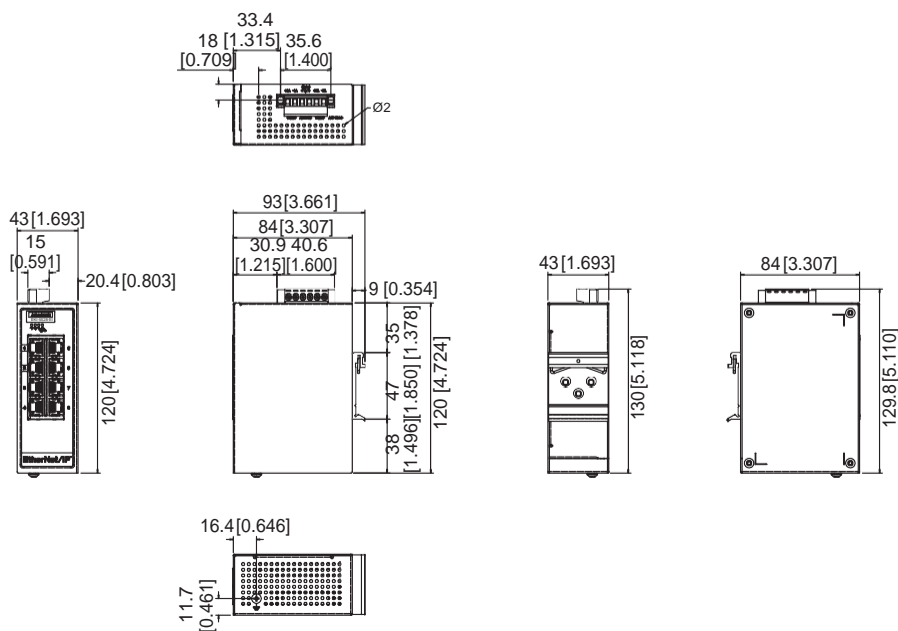

Security

- ③ **Port Security** Static, Dynamic, MAC address filtering
- ③ **Authentication** 802.1x (Port-Based, MD5/TLS/TTLS/PEAP Encryption)

Management

- ③ **DHCP** Client, Option 82
- ③ **Access** SNMP v1/v2c/v3, WEB, Standard MIB, Private MIB
- ③ **Software upgrade** TFTP, HTTP, Dual Image
- ③ **NTPSntp client**
- ③ **Data** Syslog
- ③ **Protocols** IPV6, LLDP, EtherNet/IP

Ordering Information

- ③ **EKI-5526-EI-AE** 16 port entry-level managed switch support EtherNet/IP
- ③ **EKI-5526I-EI-AE** 16 port entry-level managed switch support EtherNet/IP w/wide temp.
- ③ **EKI-5528-EI-AE** 8 port entry-level managed switch support EtherNet/IP
- ③ **EKI-5528I-EI-AE** 8 port entry-level managed switch support EtherNet/IP w/wide temp.

120 [4.724]

11.7
[0.461]

11.1
[0.439]

38 47 35
[1.496][1.850][1.378]
120 [4.724]

129.8[5.110]

120 [4.724]