

Model:

Food Prep Table:

SPS-48-12

Solid Door Sandwich / Salad Unit



SPS-48-12

- **Stainless steel interior and exterior** retains attractive finish longer. Matching aluminium finished back
- **Rounded corner** design inside of the cabinet makes it easy to clean the inside storage room
- **Standard door features:**
Positive seal self-closing door(s) with 90° stay open feature.
Magnetic door gasket(s) removable without tools for easy of cleaning
- **R290 Refrigeration system** holds 33°F to 41°F (0.5°C to 5°C) for the best in food preservation.
- **Electronic control system:**
Adjustable temperature set point and defrost frequency
Error codes to diagnose service issues
- **Shelf:** Adjustable, heavy duty PVC coated shelves.
- **Standard heavy-duty casters** make it easy to move and clean underneath
- **Condensing unit** access in back of cabinet, slides out for easy maintenance
- **Insulated lid** on prep units helps maintain food freshness.

Rough-In Data

Specifications subject to change without notice.

Chart dimensions rounded up to the nearest 1/8" (millimeters rounded up to next whole number).

Model	Doors	Shelves	Cabinet Dimensions (inches) (mm)			CAP. CU.FT. LITER	HP	Voltage	Amps	NEMA Config.
			L	D	H					
SPS-48-12	2	2	46-3/4 1188	29-1/2 750	42-1/4 1075	9.5 268	1/3+	115/60/1	6.1	5-15P 

Plug type varies by country.



SABA

Add: 3390 Enterprise Avenue, Hayward, CA 94545-3228

Tel: (510) 293-0189 Fax: (510) 293-0199 E-mail: info@sabacorpusa.com Website: www.sabacorpusa.com

SPS-48-12 Plan View

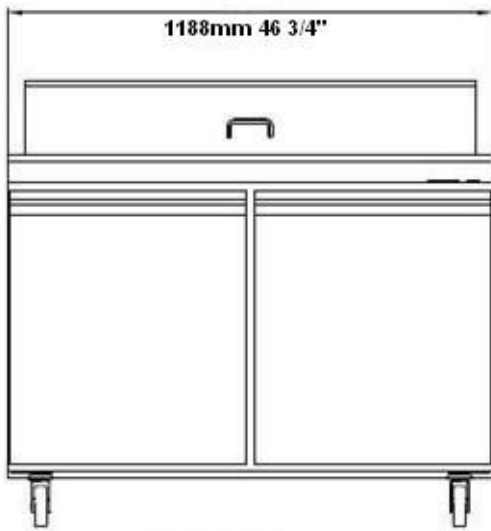

Elevation

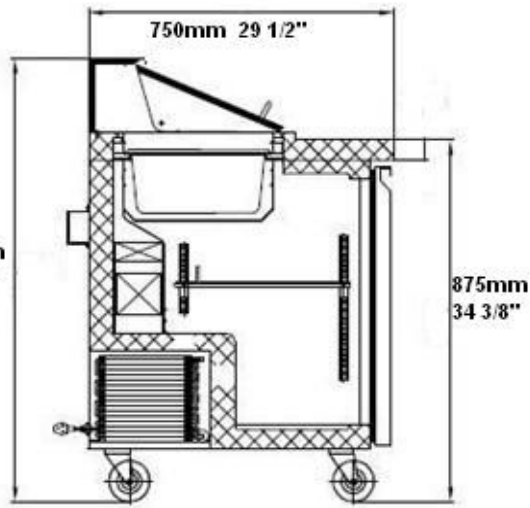

Section View

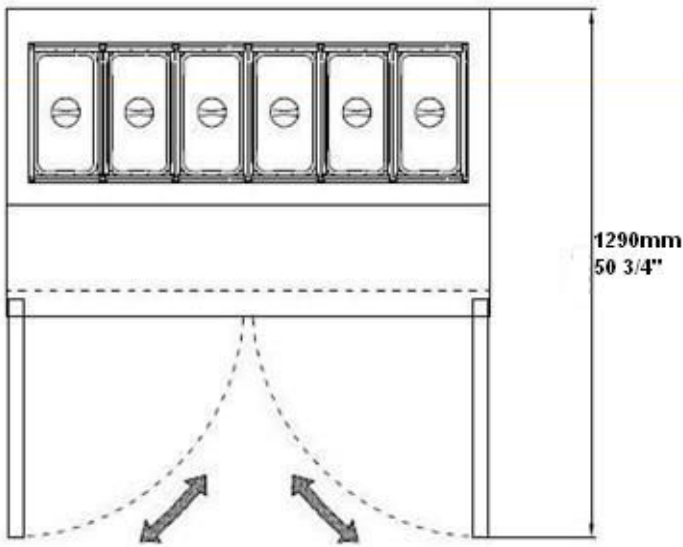

Plan

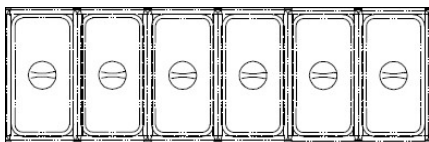

PAN LAYOUTS 1
6 (pcs) 1/3 pans



PAN LAYOUTS 2
12 (pcs) 1/6 pans