

# Gas Stock Pot Range

**SABA**

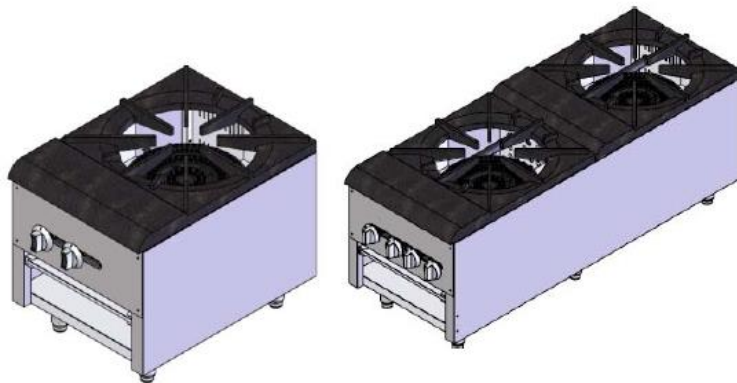

**This manual contains important information regarding your purchased equipment. Please read the manual thoroughly prior to equipment set-up, operation and maintenance.**

**Failure to comply with regular maintenance guidelines outlined in this manual may void the warranty. Please keep it for future reference after installation and do not throw it away!**

**This is a universal installation and operation instruction book which would apply to different models.**

**PLEASE READ!!!**

SABA

3390 Enterprise Ave., Hayward, CA 94545

Toll Free: +1 (844) 422-8900 Telephone: +1 (510) 293-0189 Fax: +1 (510) 293-0199

## **WARNINGS**

- Do not store or use gasoline or other flammable vapors or liquids in the vicinity of this or any other equipment.
- Improper installation, adjustment, alteration, service or maintenance can cause property damage, injury or death.
- Read the installation and maintenance instructions thoroughly before installing or servicing this equipment.
- Have the equipment installed by a qualified installer in accordance with all federal, state and local codes.
- Do not install or use without all 4 legs.
- This equipment is for use in non-combustible locations only.
- Do not obstruct the flow of combustion and ventilation air.
- Do not spray controls or the outside of the equipment with liquids or cleaning agents
- Allow for hot parts to cool before cleaning or moving.
- This equipment should only be used in a flat, level position.
- Do not operate unattended.
- Any loose dirt or metal particles that are allowed to enter the gas lines on this equipment will damage the valve and affect its operation.
- If you smell gas, follow the instructions provided by the gas supplier. Do not touch any electrical switch; do not try to light the burner; do not use a telephone within close proximity.
- Never attempt to move grates while cooking.

## **SET UP**

1. Remove all packing material and tape, as well as any protective plastic from the equipment.
2. Place the equipment in the desired position and height.
3. Install the four (4) legs onto the equipment.
4. Clean and dry the equipment thoroughly before using.

## **INSTALLATION:**

**The installation of this equipment must conform with local codes, or with the National Gas Code, ANSIZ223.1/NFPA 54, or the Natural Gas and Propane Installation Code, CSA B149.1, as applicable.**

- The equipment and its individual shutoff valve must be disconnected from the gas supply piping system during any pressure testing of that system at test pressures in excess of ½ psi (3.5 kPa).
- The equipment must be isolated from the gas supply piping system by closing its individual manual shutoff valve during any pressure testing of the gas supply piping system at test pressures equal to or less than ½ psi (3.5 kPa).

### **Clearance and positioning around the equipment:**

The installation location must be kept free and clear of combustibles. Do not obstruct the flow of combustion and ventilation air. DO NOT install the stockpot adjacent to open burners or fryers. Sufficient air should be allowed to enter the room to compensate for the amount of air removed by any ventilating system and for combustion of the gas burners. Do not obstruct the air flow into and around the appliance. Do not obstruct the flow of flue gases through and above the stockpot top grate. Position the stockpot in its final location. Check that there are sufficient clearances to service the stockpot and to make the required gas supply connection(s). Provide 24" clearance at the front

for cleaning, maintenance, service and proper operation.

Minimum Clearance	Combustible Construction	Non-Combustible Construction
Rear	24"	4"
Sides	18"	0"

#### **Air Supply and ventilation:**

- The area in front and around the equipment must be kept clear to avoid any obstruction of the flow of combustion and ventilation air.
- Adequate clearance must be maintained at all times in front of and at the sides of the equipment for servicing and proper ventilation.

#### **Pressure Regulator:**

- All commercial cooking equipment must have a pressure regulator on the incoming service line for safe and efficient operation. The regulator provided for this equipment is adaptable for both Natural gas and LP gas.
- Regulator specifications:  $\frac{3}{4}$ " NPT inlet and outlet, factory adjusted for same type of gas stated on the rating label standard and may be converted by qualified personnel to be used for the other type of gas. Natural gas is pre-set at 4"W/C, propane gas is pre-set at 10"W/C.

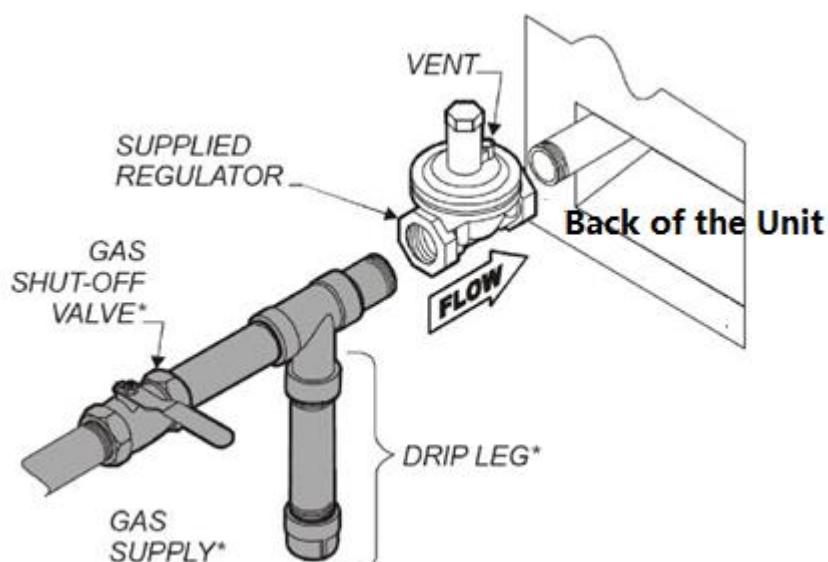

Prior to connecting the regulator, check the incoming line pressure. The regulator can only withstand a maximum pressure of  $\frac{1}{2}$  PSI (14" WC). If the line pressure is beyond this limit, a step down regulator before the regulator provided will be required. The arrow above (FLOW) shows gas flow direction and should point downstream to the equipment.

#### **GAS CONVERSION**

This unit is shipped from the factory equipped with fixed burner orifices for the type of gas printed on the rating plate. The burner orifices required to convert the unit to the other type of gas are shipped with the unit in the shipping packaging. It is recommended that a trained gas service technician with the necessary tools, instruments and skills perform the conversion.

To do the gas conversion, following steps must be completed:

1. Remove all pre-installed gas burner orifices and install the provided conversion burner orifices.
2. Set the regulator by inverting the regulator spring plug like below pictures

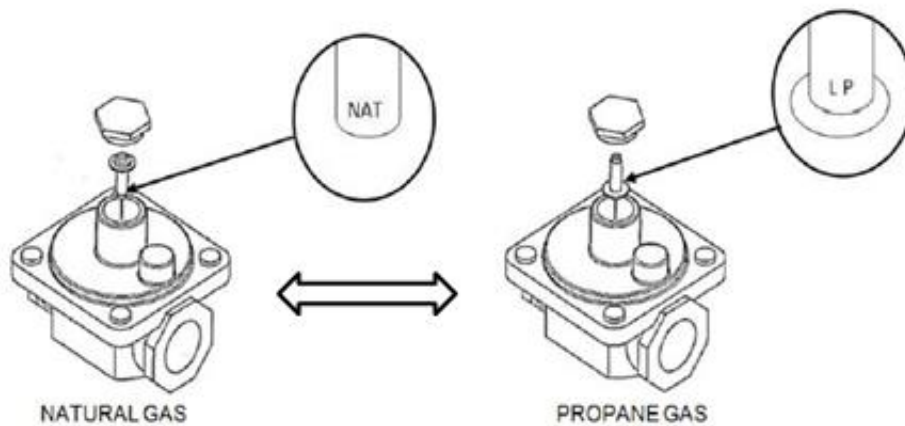

#### **LIGHTING THE PILOT:**

**The manifold units are equipped with standing pilots and each should be lit immediately after the gas is supplied to the equipment.**

1. Before attempting to light the pilots, turn off the main gas valve to the equipment and wait 5 minutes to clear the gas.
2. Turn off all gas control knobs.
3. Turn on control valve and light all pilots.
4. The pilot burner must be lit from the top. Hold an ignition source and light the pilot. When the flame is stable, remove ignition source.
5. Turn off the main gas valve to shut down the equipment.

Smoke appearing on initial start of the equipment is normal. This is a result of the painted coating burning off. Allow the equipment to “burn in” for at least 20 minutes before the first use.

#### **Pilot Flame Height Adjustment:**

- The pilot flame on the equipment has been factory adjusted. When adjustment is necessary, adjust the pilot flames as small as possible but high enough to light the burner immediately when the burner valve is turned to the highest setting. Access to the pilot flame adjustment screw is obtained through the holes in the front panel

#### **Burner Adjustment:**

- Remove the front panel to gain access. Turn burner valve knob to highest setting. Slowly decrease the air shutters to give a soft blue flame having luminous tips. Then slowly increase opening to a point where the yellow tips disappear and a hard blue flame is obtained.

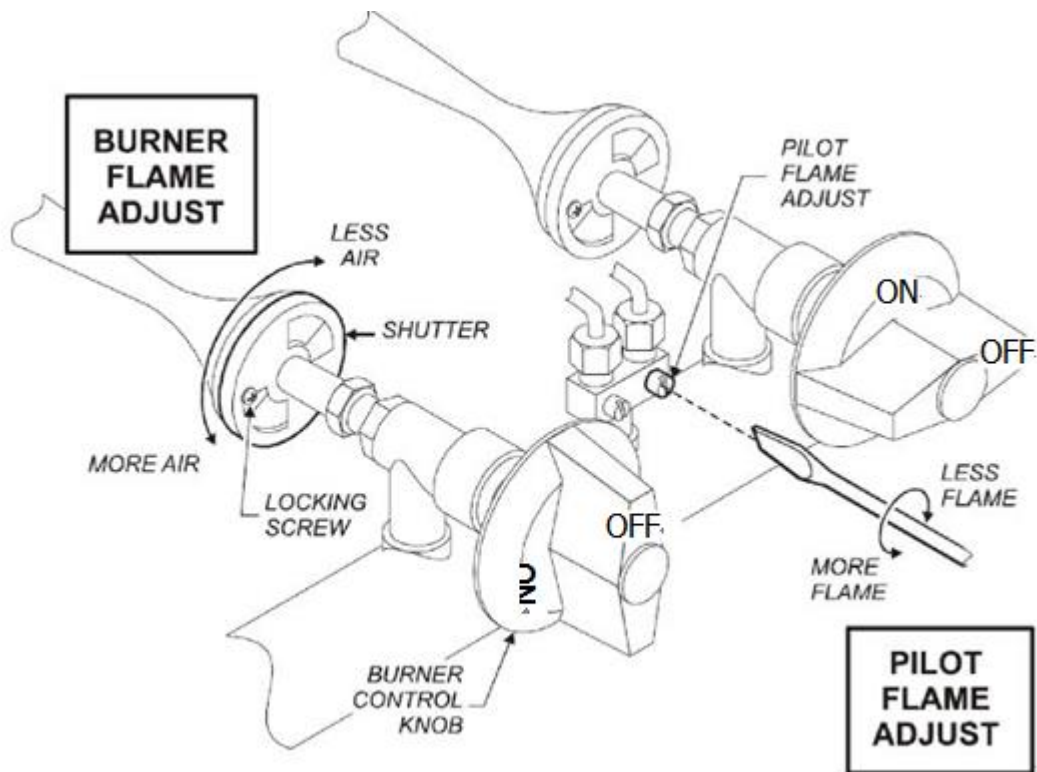

**OPERATION:**

Before initial use, turn the gas control knob to the maximum setting and allow the equipment to burn-in for 20 minutes.

Seeing smoke coming from the cooking surface is normal during burn-in. After 20 minutes of burn-in, equipment is ready for use.

1. To ignite the burners, depress and turn the gas control knob to high position
2. After cooking is done, please turn the valve to off position.

**CLEANING:**

To maintain the appearance and increase the service life, clean your equipment daily.

**DO NOT** clean equipment with steel wool.

1. Allow the equipment to cool completely before cleaning.
2. Using a wire brush, scrape the grill grate(s) to remove any food residue.
3. To clean equipment, use either a damp cloth, sponge with soapy water.
4. Dry grates thoroughly to prevent rusting.
5. Empty and clean the drip tray.

**MAINTENANCE:**

- A qualified service company should check the unit for safe and efficient operation on an annual basis.
- Gas piping shall be a certain size and installed to provide a supply of gas sufficient to meet the full gas input of the equipment.
- A manual shut off valve should be installed upstream from the manifold within 4 ft. (1.2m) of the equipment and in a position where it can be reached in the event of an emergency.
- Check entire gas piping system for leaks every so often. Using a gas leak detector or soapy water

solution is recommended.

- Install equipment under efficient exhaust hood with flameproof filters with a distance of no less than 4 feet between the top of the equipment and the filters or any other combustible materials.

Pilot Outage	<ol style="list-style-type: none"> <li>1. Pilot flame too low</li> <li>2. Restriction in pilot orifice</li> <li>3. Restriction in pilot valve</li> </ol>
Improper burner combustion	<ol style="list-style-type: none"> <li>1. Improper ventilation</li> </ol>
Poor Ignition	<ol style="list-style-type: none"> <li>1. Insufficient gas input</li> <li>2. Poor air-gas adjustment</li> <li>3. Restriction in pilot orifice</li> <li>4. Restriction in main burner ignition port</li> <li>5. Restriction in control valve</li> <li>6. Restriction in gas orifice</li> </ol>

Product Specification Sheet

MODEL	Natural Gas BTU/hr Input Rating	Propane Gas BTU/hr Input Rating	Qty of burners
SP-1	110,000	85,000	1 outer+1 inner
SP-2	220,000	170,000	2 outer+2 inner

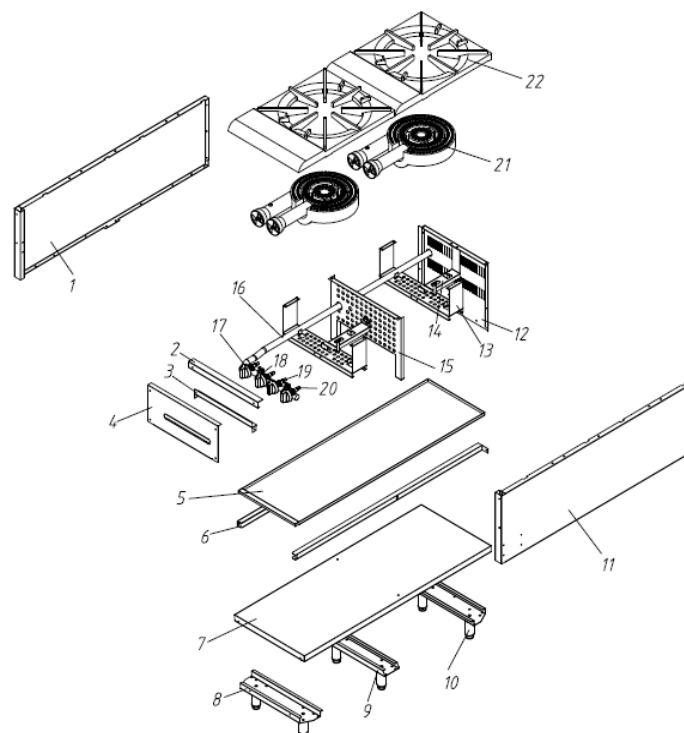

S/N	SP-1	SP-2	Description
1	20228023025	20228057003	Left side sheet
2	20228023029	20228057014	Front reinforcement sheet
3			Front cross sheet
4	20228023023	20228057001	Front panel
5	20228023010	20228057011	Crumb tray
6	20228023009	20228057009	Crumb tray runner
7	20228023005	20228057005	Bottom board
8	20228023011	20228023011	Leg support board
9	N/A	20228057012	Middle leg support board for SP-2
10	302090138	302090138	Leg
11	20228023024	20228057002	Right side board
12	20228023026	20228057006	Rear board
13	20228023027	20228023027	Burner bracket
14	20228023028	20228023028	Burner connecting board
15			Nozzle fixing board
16	302180115	302060097	Venturi pipe
17	301110459	301110459	Knob
18	302220027	302220027	Pilot valve
19	302220059	302220059	Valve
20	302150059	302150059	Nozzle
21	302250052	302250052	Burner
22	302250053	302250053	Grate