

24028

28

(IT) ISTRUZIONI DI MONTAGGIO (GB) FITTING INSTRUCTIONS (E) INSTRUCCIONES PARA SU MONTAJE (D) MONTAGEANWEISUNGEN (F) INSTRUCTIONS DE MONTAGE (NL) MONTAGE INSTRUCTIES (P) INSTRUÇÕES DE MONTAGEM (H) SZERELÉSI UTASITÁS (PL) INSTRUKCJA MONTAZU (SLO) NAVODILA O MONTAŽI (HR) UPUTE ZA MONTAŽU.

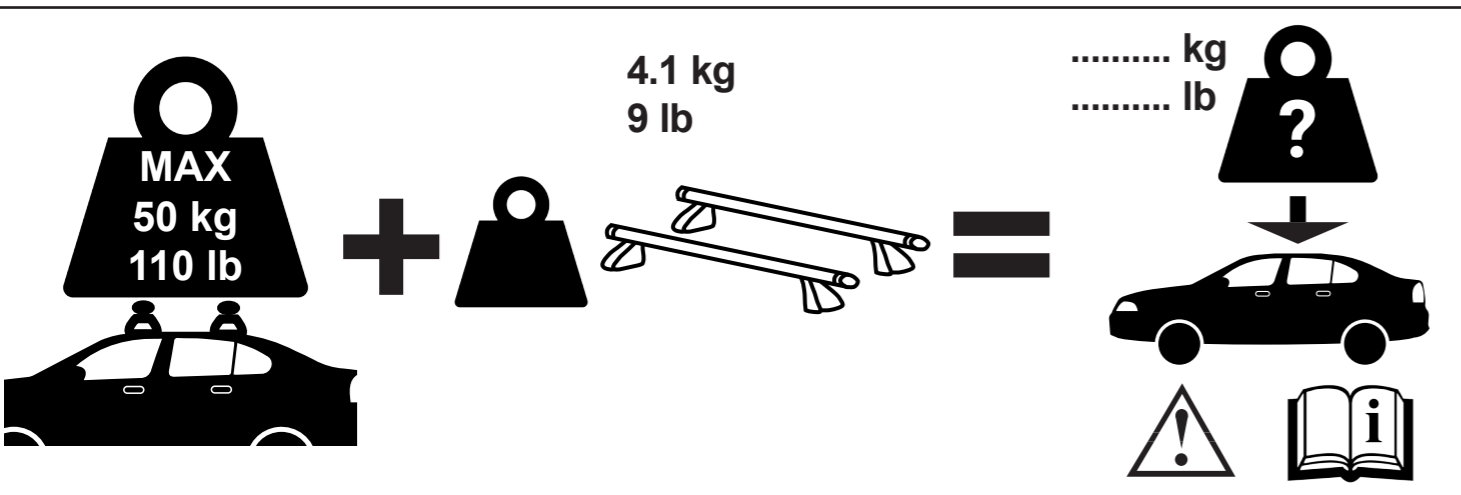
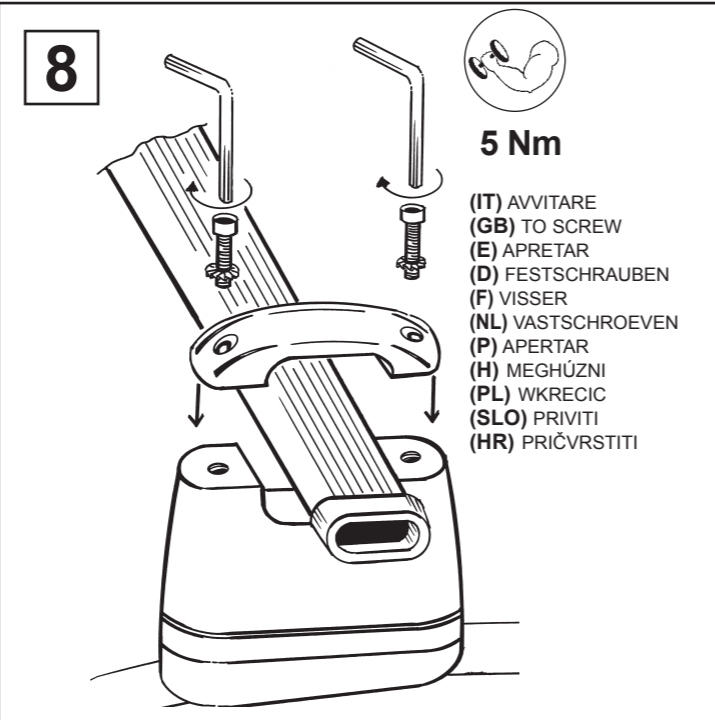
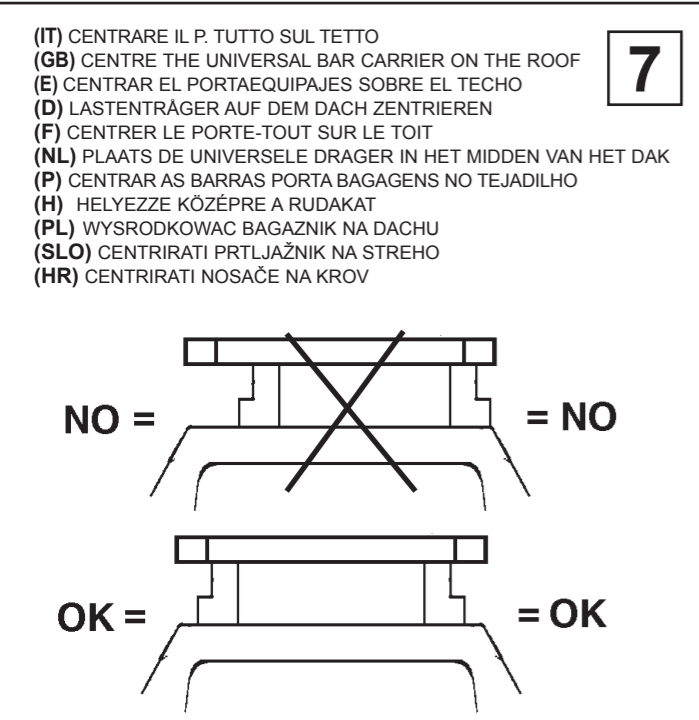
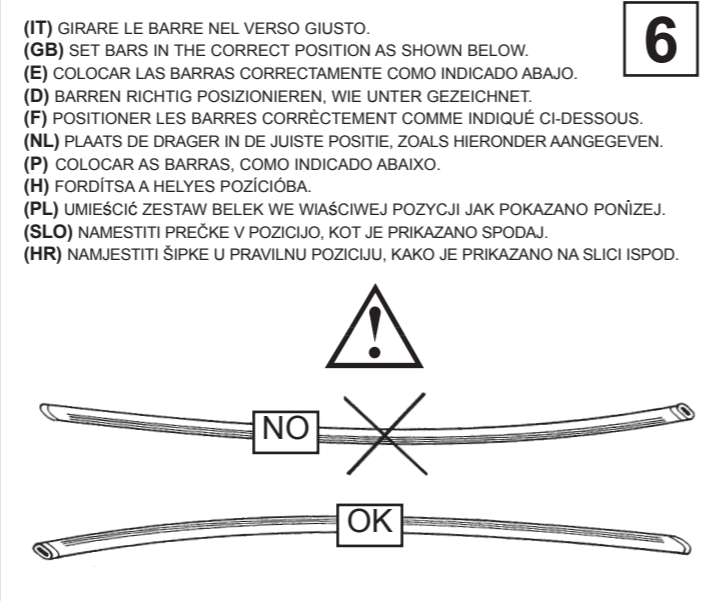
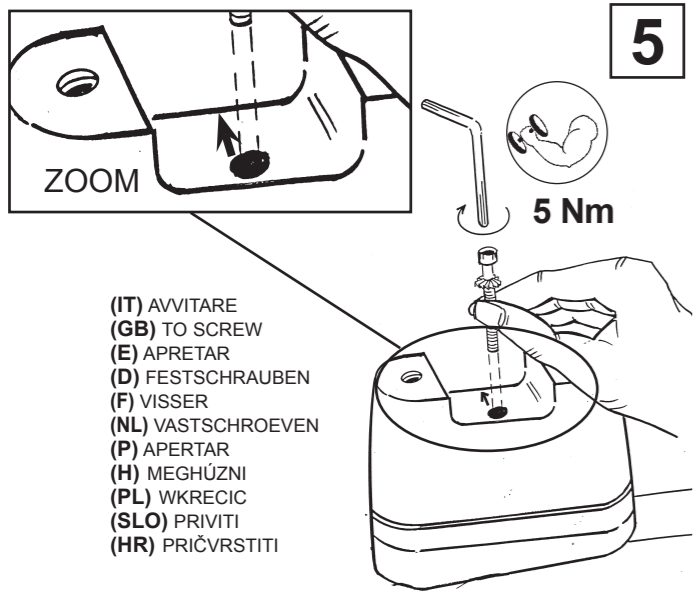

1

(IT) MODELLI AUTO (GB) CARS (E) COCHES (D) WAGEN (F) VOITURES (NL) AUTO (P) MODELO AUTO (H) AUTÓ TIPUS (PL) MODELE SAMOCHODÓW (SLO) MODELI AVTOMOBILOV (HR) MODELI AUTA

**CITROEN: C5 I 5P (01->08)**  
**PEUGEOT: 307 3-5P (01->08)**  
**PEUGEOT: 607 4P (00->10)**

“À TROUVER SUR LE BATTANT DE LA PORTE OU DANS LE MANUAL TECHNIQUE DE LA VOITURE”

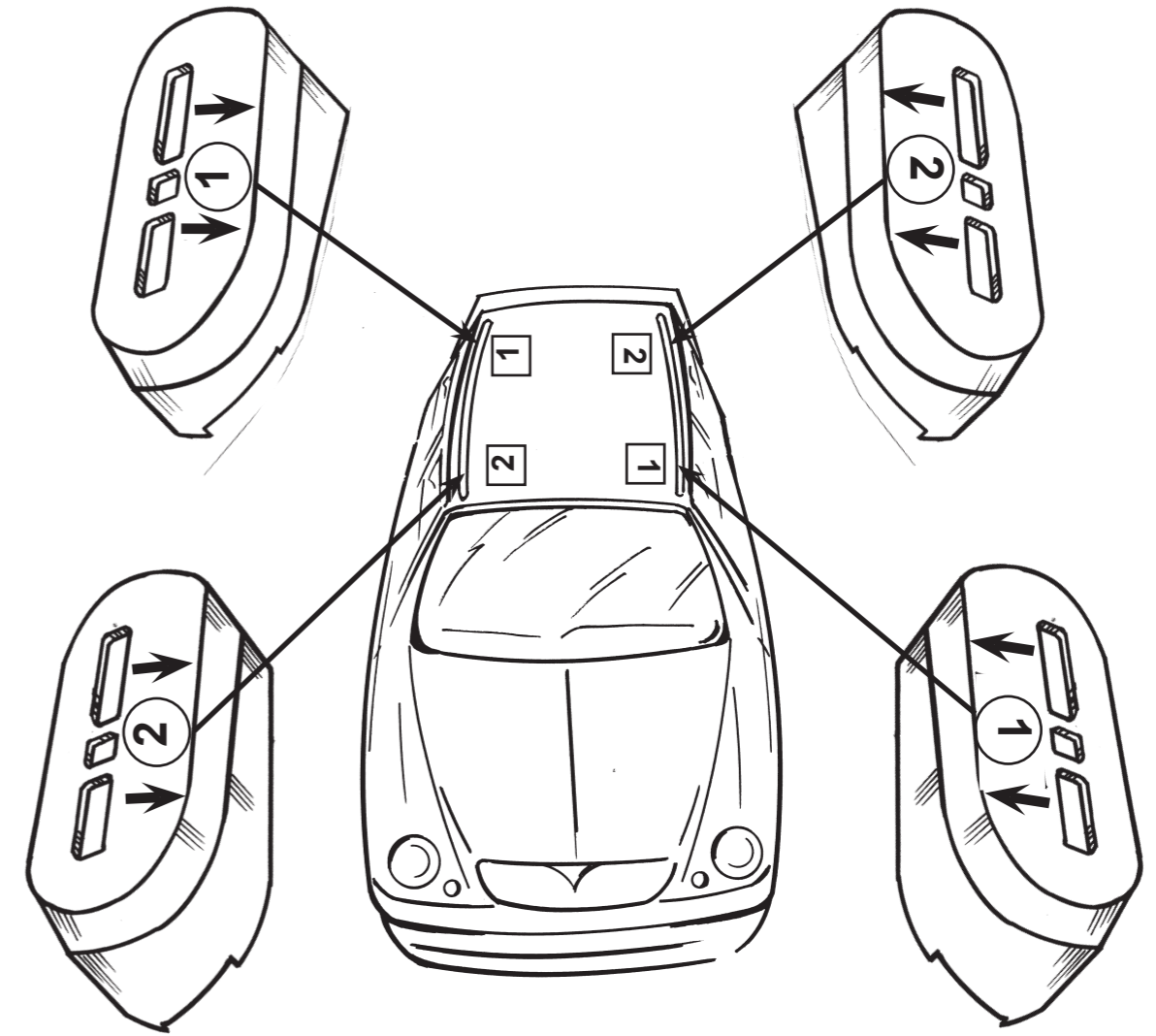

IST\_24028\_00\_2110

**2**

(IT) MODELLI AUTO (GB) CARS (E) COCHES (D) WAGEN (F) VOITURES (NL) AUTO (P) MODELO AUTO  
 (H) AUTÓ TIPUS (PL) MODELE SAMOCHODÓW (SLO) MODEL AVTOMOBILOV (HR) MODEL AUTA

## FORD: Mondeo III 4-5P (01->07)

“À TROUVER SUR LE BATTANT DE LA PORTE OU  
 DANS LE MANUAL TECHNIQUE DE LA VOITURE “

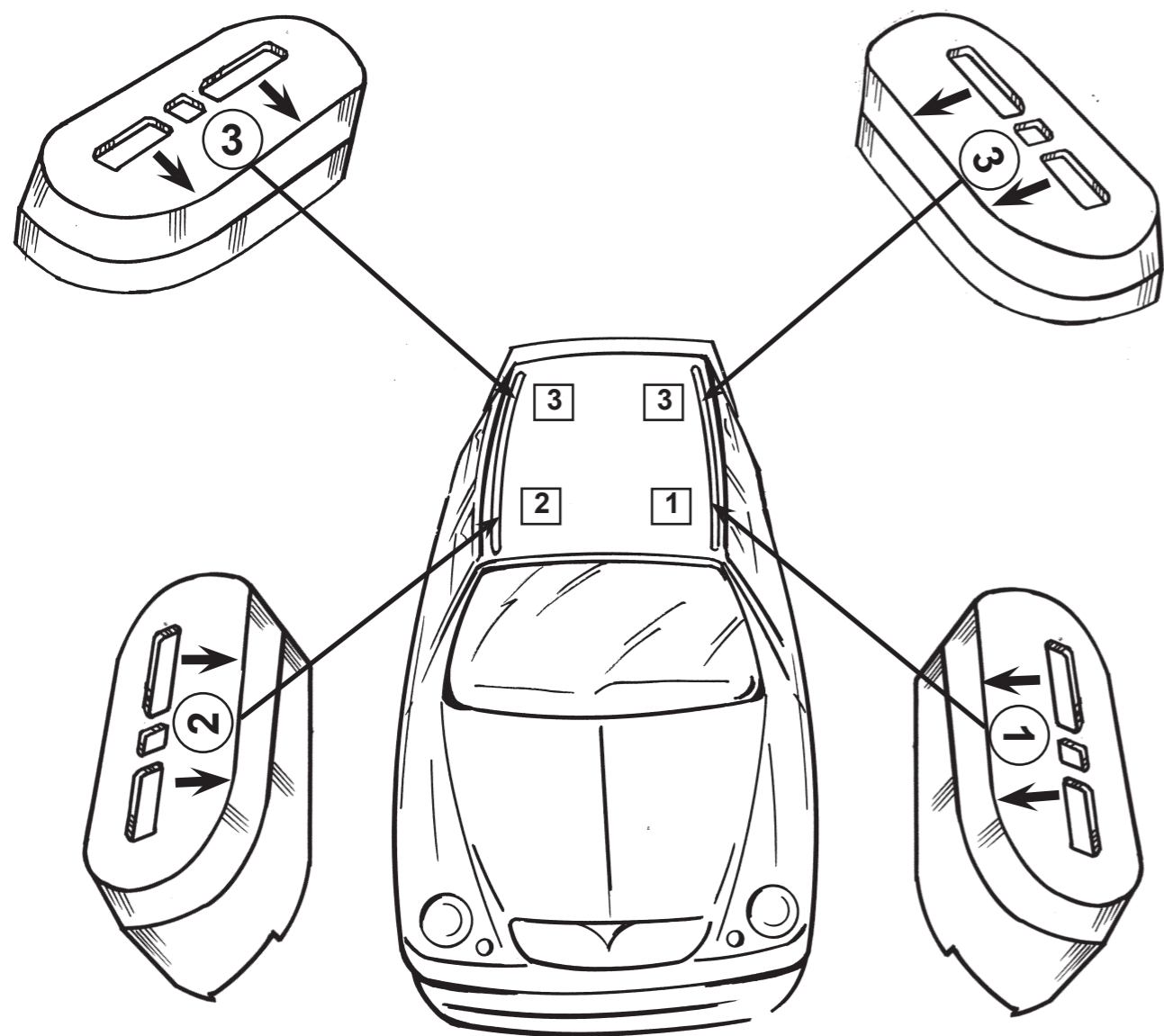
**3**

(IT) TETTO VETTURA  
 (GB) ROOF AUTO  
 (E) TECHO DEL VEHÍCULO  
 (D) DACH AUTOMOBILE  
 (F) TOIT VOITURE  
 (NL) AUTO DAK  
 (P) TEJADILHO DA VIATURA  
 (H) AUTÓ TETÓ  
 (PL) DACH SAMOCHODU  
 (SLO) STREHA VOZILA  
 (HR) KROV AUTOMOBILA

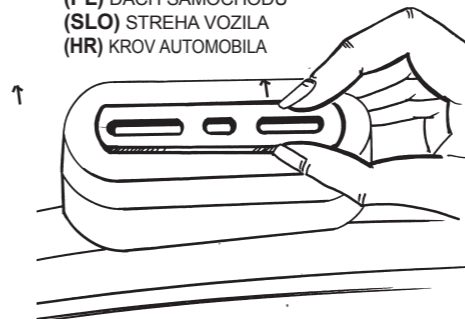
**4A**

PEUGEOT 307 3-5P (01->08)

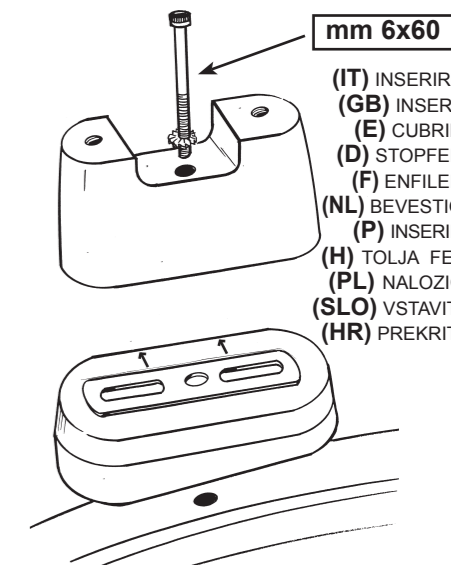

mm 6x60  
 (IT) INSERIRE  
 (GB) INSERT  
 (E) CUBRIR  
 (D) STOPFEN  
 (F) ENFILER  
 (NL) BEVESTIG  
 (P) INSERIR  
 (H) TOLJA FEL  
 (PL) NALOZIC  
 (SLO) VSTAVITI  
 (HR) PREKRITI

**4B**

CITROEN C5 I 5P (01->08)  
 PEUGEOT 607 4P (00->10)

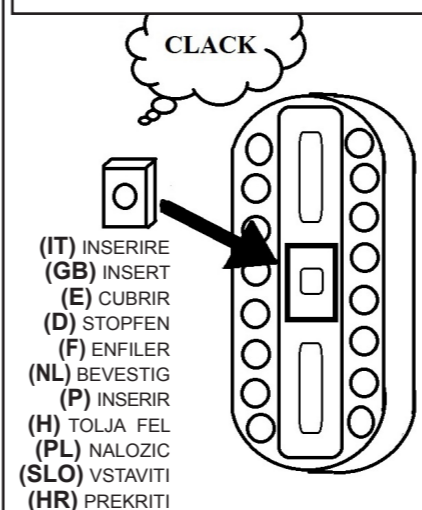

CITROEN C5 I 5P (01->08)  
 PEUGEOT 607 4P (00->10)

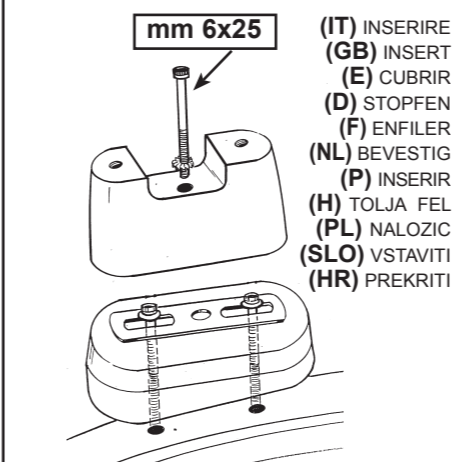

CITROEN C5 I 5P (01->08)

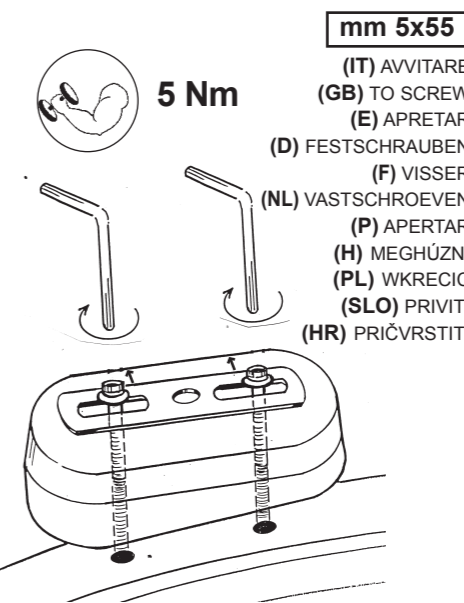

PEUGEOT 607 4P (00->10)

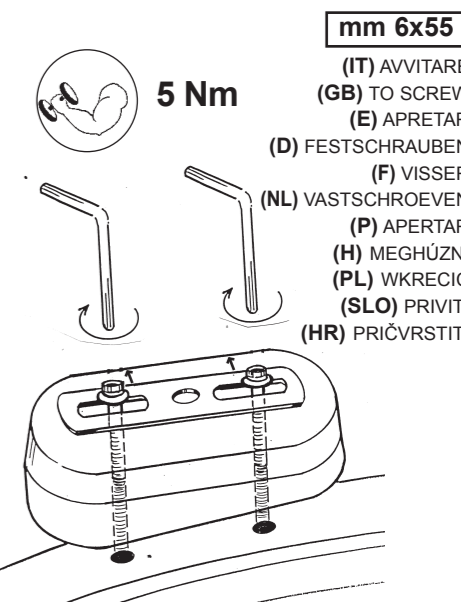
**4C**

FORD MONDEO III 4-5P (01->07)

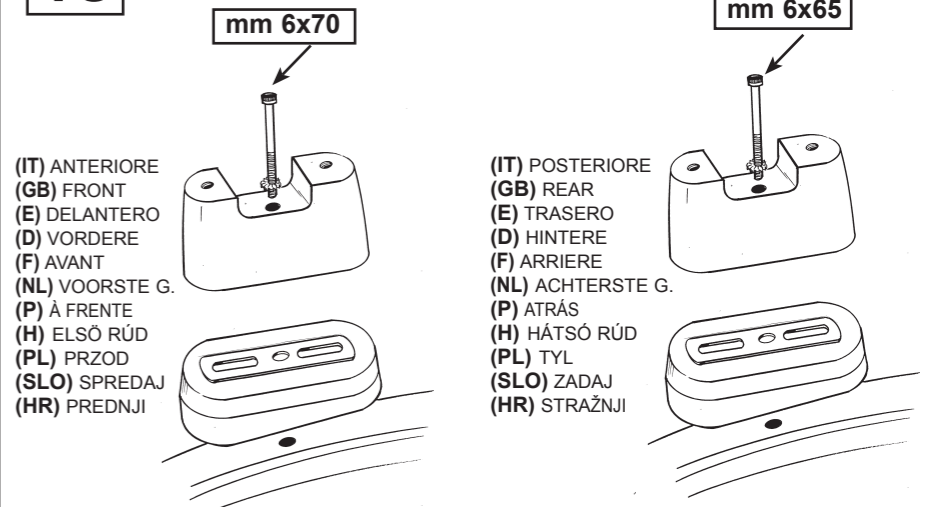

(IT) ANTERIORE  
 (GB) FRONT  
 (E) DELANTERO  
 (D) VORDERE  
 (F) AVANT  
 (NL) VOORSTE G.  
 (P) À FRENTE  
 (H) ELSŐ RÚD  
 (PL) PRZOD  
 (SLO) SPREDAJ  
 (HR) PREDNJI

(IT) POSTERIORE  
 (GB) REAR  
 (E) TRASERO  
 (D) HINTERE  
 (F) ARRIERE  
 (NL) ACHTERSTE G.  
 (P) ATRÁS  
 (H) HÁTSÓ RÚD  
 (PL) TYŁ  
 (SLO) ZADAJ  
 (HR) STRAŽNJI