

## COVER

(IT) ISTRUZIONI DI MONTAGGIO (GB) FITTING INSTRUCTIONS (F) INSTRUCTIONS DE MONTAGE  
(D) MONTAGEANWEISUNGEN (E) INSTRUCCIONES PARA SU MONTAJE (P) INSTRUÇÕES DE MONTAGEM  
(NL) MONTAGE INSTRUCTIES (H) SZERELÉSI UTASÍTÁS (PL) INSTRUKCJA MONTAŻU  
(SLO) NAVODILA ZA MONTAŽO (HR) UPUTSTVO ZA MONTAŽU

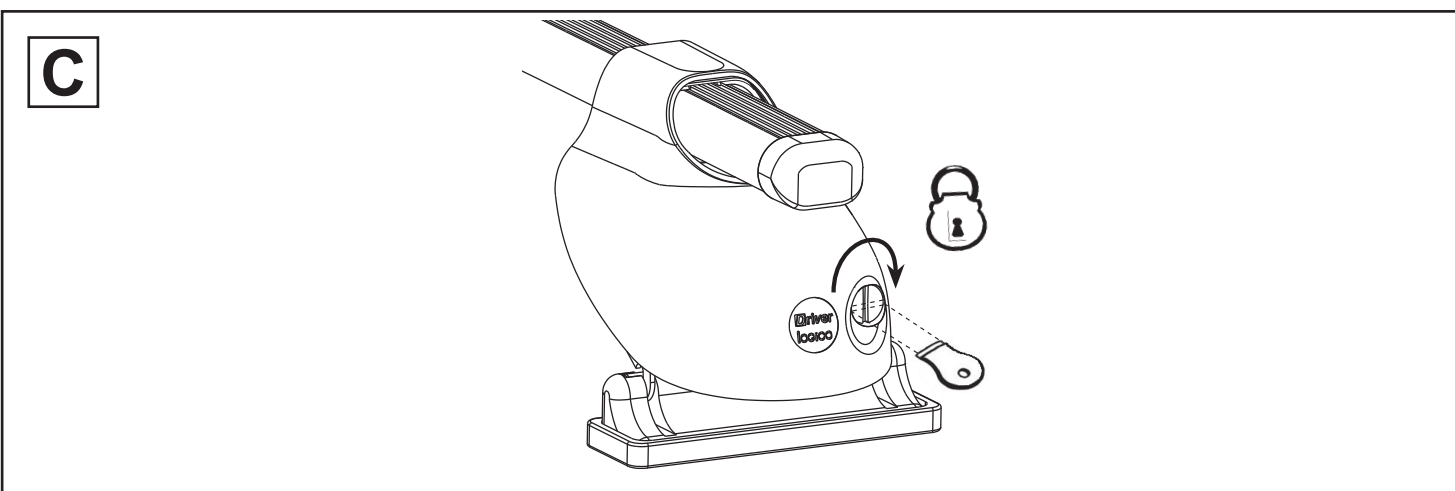
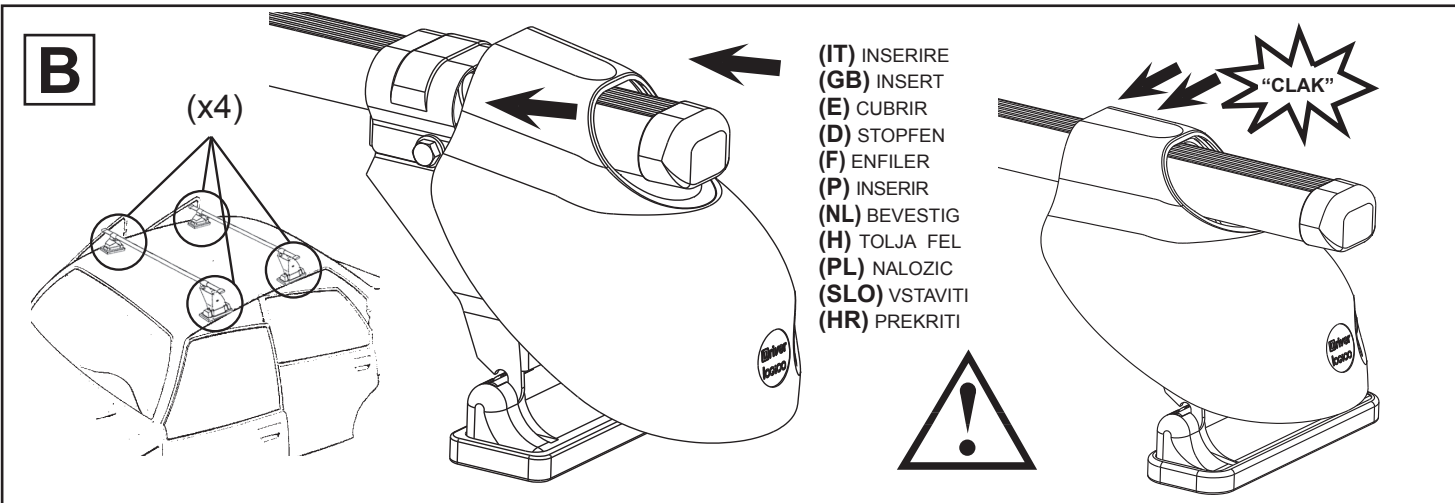
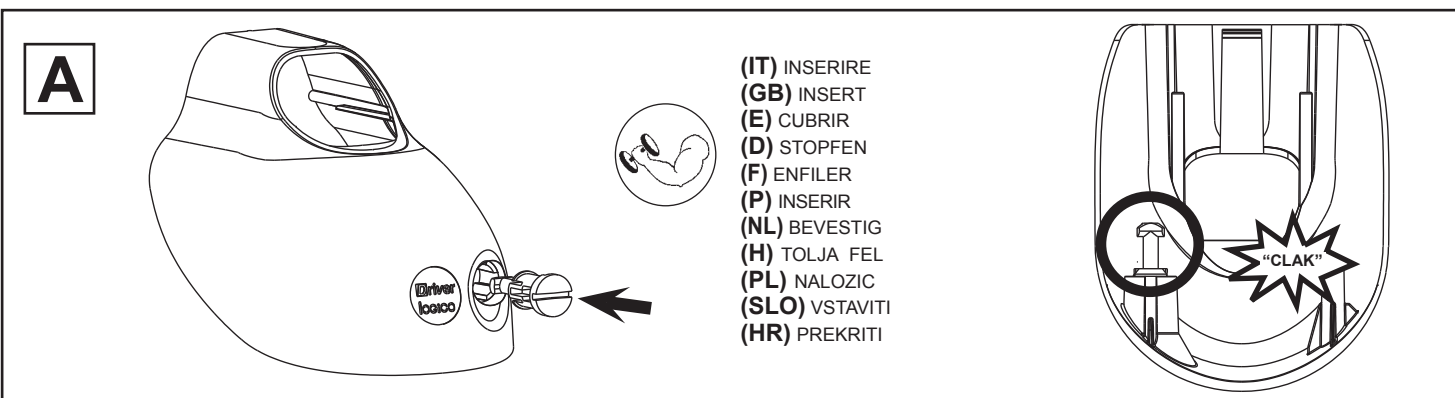

# 24019

# 19

(IT) ISTRUZIONI DI MONTAGGIO (GB) FITTING INSTRUCTIONS (E) INSTRUCCIONES PARA SU MONTAJE  
(D) MONTAGEANWEISUNGEN (F) INSTRUCTIONS DE MONTAGE (NL) MONTAGE INSTRUCTIES (P) INSTRUÇÕES DE MONTAGEM  
(H) SZERELÉSI UTASÍTÁS (PL) INSTRUKCJA MONTAŻU (SLO) NAVODILA O MONTAŽI (HR) UPUTE ZA MONTAŽU

**1**

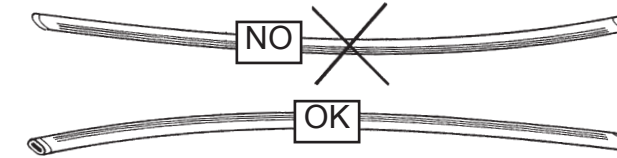

(IT) GIRARE LE BARRE NEL VERSO GIUSTO.  
(GB) SET BARS IN THE CORRECT POSITION AS SHOWN BELOW.  
(E) COLOCAR LAS BARRAS CORRECTAMENTE COMO INDICADO ABAJO.  
(D) BARREN RICHTIG POSITIONIEREN, WIE UNTER GEZEICHNET.  
(F) POSITIONNER LES BARRES CORRÈCTEMENT COMME INDIQUÉ CI-DESSOUS.  
(NL) PLAATS DE DRAGER IN DE JUISTE POSITIE, ZOALS HIERONDER AANGEGEVEN.  
(P) COLOCAR AS BARRAS, COMO INDICADO ABAIXO.  
(H) FORDÍTSÁ A HELYES POZÍCIÓBA.  
(PL) UMIĘCÍĆ ZESTAW BELEK WE WIAŚCIWEJ POZYCJI JAK POKAZANO PONIEJ.  
(SLO) NAMESTITI PREČKE V POZICIJU, KOT JE PRIKAZANO SPODAJ.  
(HR) NAMJESTITI ŠIPKE U PRAVLINU POZICIJU, KAKO JE PRIKAZANO NA SLICI ISPOD.

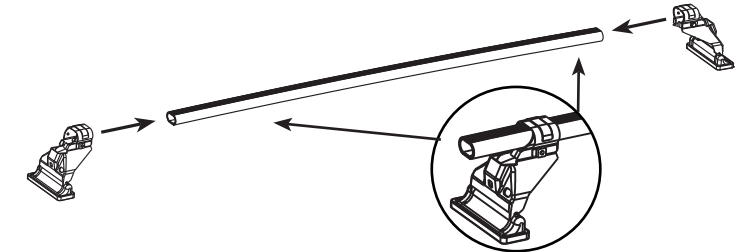

**2**

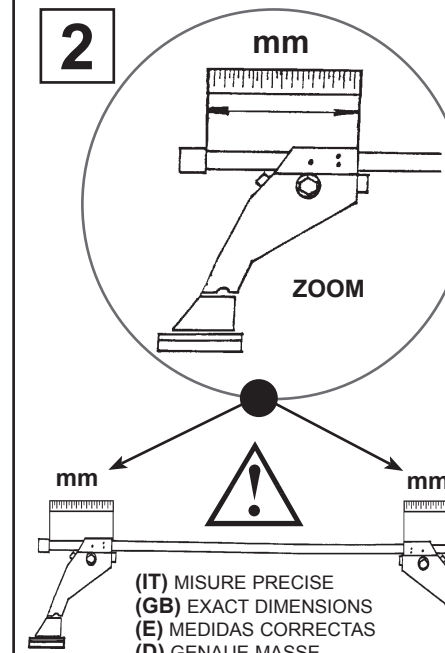

(IT) MISURE PRECISE  
(GB) EXACT DIMENSIONS  
(E) MEDIDAS CORRECTAS  
(D) GENAUE MASSE  
(F) MESURES EXACTES  
(NL) EXACTE AFMETINGEN  
(P) MEDIDAS PRECISAS  
(H) PONTOS MÉRET  
(PL) DOKŁADNE WYMIARY  
(SLO) TOČNE MERE  
(HR) PRECIZNE MJERE

(IT) MODELLI AUTO (GB) CARS (E) COCHES (D) WAGEN (F) VOITURES	(NL) AUTO (P) MODELO AUTO (H) AUTÓ TIPUS (PL) MODELE SAMOCHODÓW (SLO) MODELI AVTOMOBILOV (HR) MODELI AUTA	(IT) ANTERIORE (GB) FRONT (E) DELANTERO (D) VORDERE (F) AVANT	(NL)VOORSTE G. (P) À FRENTE (H) ELSÓ RÚD (PL) PRZOD (SLO) SPREDAJ (HR) PREDNJI	(IT) POST. (GB) REAR (E) TRASERO (D) HINTERE (F) ARRIERE	(NL) ACHTERSTE G. (P) ATRAS (H) HÁTSÓ RÚD (PL) TYŁ (SLO) ZADAJ (HR) STRAŽNJI
ALFA ROMEO 166 4P (98->07)		105 mm			94 mm
BMW Serie 3 Coupè 3P (92->99)		116 mm			116 mm
CITROËN C1 I 5P (05->14)		118 mm			130 mm
CITROËN C1 II 5P (14->)		103 mm			113 mm
FIAT Brava 5P (95->01)		136 mm			136 mm
FIAT Marea 4P (96->07)		136 mm			136 mm
FIAT Panda II 5P (03->12) No rails/ Ohne reling		92 mm			99 mm
HONDA Civic VI 5P (94->00)		138 mm			126 mm
HONDA Concerto 4-5P (88->94)		108 mm			121 mm
HYUNDAI Getz 5P (02->09)		106 mm			101 mm
HYUNDAI i10 5P (07->13)		109 mm			109 mm
MAZDA 2 I 5P (04->07)		111 mm			114 mm
PEUGEOT 107 5P (05->14)		118 mm			130 mm
PEUGEOT 108 5P (14->) (No versione TOP!)/(No TOP! version)/(keine TOP! Version)/(Non version TOP!)		103 mm			113 mm
ROVER 45 4-5P (00->05)		133 mm			131 mm
ROVER 400 4-5P (95->99)		133 mm			131 mm
SKODA Felicia I 4P (94->97)		136 mm			143 mm
SKODA Felicia II 4P (98->01)		136 mm			143 mm
TOYOTA Aygo I 5P (05->14)		118 mm			130 mm
TOYOTA Aygo II 5P (14->)		103 mm			113 mm
VOLKSWAGEN Golf II 3-5P (83->92)		153 mm			153 mm

**3**

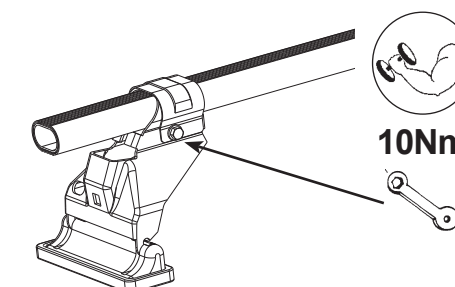

(IT) AVVITARE (A FONDO)  
(GB) TO SCREW (DOWN)  
(E) APRETAR (A FONDO)  
(D) FESTSCHRAUBEN  
(F) VISSER (À FOND)  
(NL) VASTSCHROEVEN  
(P) APERTAR POR BAIXO  
(H) MEGHÚZNI  
(PL) WKRECIC DO KONCA  
(SLO) PRIVITI (DO KONCA)  
(HR) PRIČVRSTITI (DO KRAJA)

4

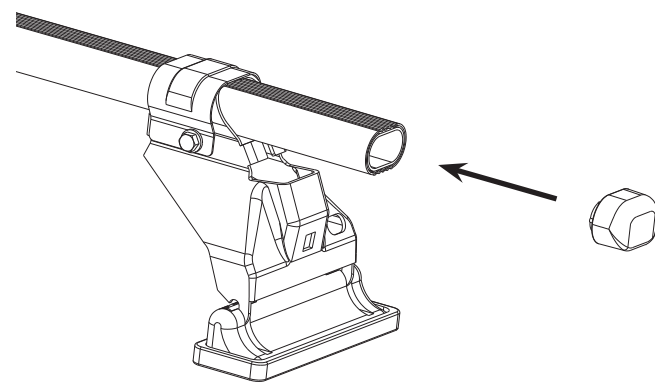

(IT) INSERIRE  
(GB) INSERT  
(E) CUBRIR  
(D) STOPFEN  
(F) ENFILER  
(NL) BEVESTIG  
(P) INSERIR  
(H) TOLJA FEL  
(PL) NALOZIC  
(SLO) VSTAVITI  
(HR) PREKRITI

(IT) MODELLI AUTO (GB) CARS (E) COCHES (D) WAGEN (F) VOITURES (NL) AUTO (P) MODELO AUTO (H) AUTÓ TIPUS (PL) MODELE SAMOCHODÓW (SLO) MODELI AVTOMOBILOV (HR) MODELI AUTA	(IT) ANTERIORE (GB) FRONT (E) DELANTERO (D) VORDERE (F) AVANT (NL) VOORSTE G. (P) À FRENTE (H) ELSŐ RÚD (PL) PRZOD (SLO) SPREDAJ (HR) PREDNJI	(IT) POSTERIORE (GB) REAR (E) TRASERO (D) HINTERE (F) ARRIERE (NL) ACHTERSTE G. (P) ATRÁS (H) HÁTSÓ RÚD (PL) TYL (SLO) ZADAJ (HR) STRAŽNJI
---	---	--

ALFA ROMEO 166 4P (98->07)	14	14
BMW Serie 3 Coupè 3P (92->99)	14	14
CITROËN C1 I 5P (05->14)	14	14
CITROËN C1 II 5P (14->)	14	14
FIAT Brava 5P (95->01)	25	25
FIAT Marea 4P (96->07)	25	25
FIAT Panda II 5P (03->12) No rails/ Ohne reling	25	25
HONDA Civic VI 5P (94->00)	14	14
HONDA Concerto 4-5P (88->94)	14	14
HYUNDAI Getz 5P (02->09)	14	14
HYUNDAI i10 5P (07->13)	14	14
MAZDA 2 I 5P (04->07)	14	14
PEUGEOT 107 5P (05->14)	14	14
PEUGEOT 108 5P (14->) (No versio- ne TOP!)/(No TOP! version)/(keine TOP! Version)/(Non version TOP!)	14	14
ROVER 45 4-5P (00->05)	14	14
ROVER 400 4-5P (95->99)	14	14
SKODA Felicia I 4P (94->97)	14	14
SKODA Felicia II 4P (98->01)	14	14
TOYOTA Aygo I 5P (05->14)	14	14
TOYOTA Aygo II 5P (14->)	14	14
VOLKSWAGEN Golf II 3-5P (83->92)	14	14

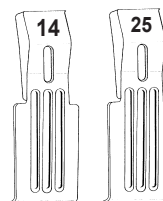

(IT) MONTAGGIO GANASCINE  
(GB) HOW TO ASSEMBLE THE CLAMPS  
(E) COMO MONTAR LAS FIJACIONES  
(D) ZUSAMMENBAU DER SPANNBACKEN  
(F) MONTAGE PATTE  
(NL) MONTAGE VAN DE KLEMMEN  
(P) COMO FIXAR OS SUPORTES  
(H) RÖGZÍTŐ FÜLEK  
(PL) MONTAZ SZCZEK MOCUJACYCH  
(SLO) MONTAŽA NAPENJALNIKA  
(HR) MONTAŽA ČELJUSTI

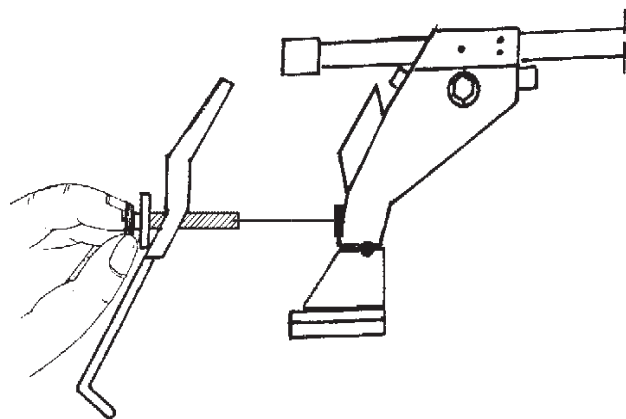

5

6

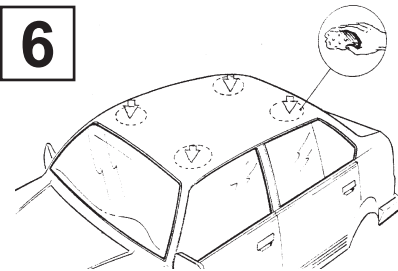

(IT) PULIRE IL TETTO  
(GB) CLEAN THE ROOF  
(E) LIMPIAR EL TECHO  
(D) DACH REINIGEN  
(F) NETTOYER LE TOIT  
(NL) DAK SCHOONMAKEN  
(P) LIMPAR O TEJADILHO  
(H) TISZTÍTSA MEG A TETŐT  
(PL) WYCZYSZC DACH  
(SLO) OČISTITI STREHO  
(HR) ČIŠĆENJE KROVA

7

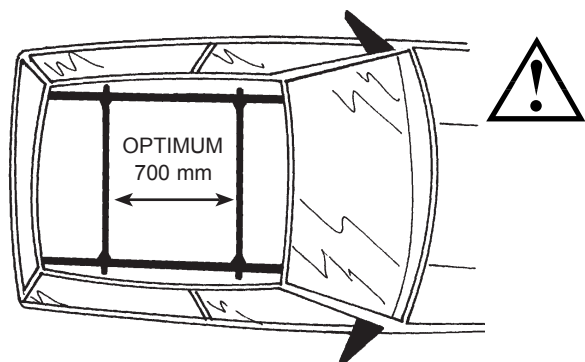

(IT) CENTRARE IL P. TUTTO SUL TETTO  
(GB) CENTRE THE UNIVERSAL BAR CARRIER ON THE ROOF  
(E) CENTRAR EL PORTAEQUIPAJES SOBRE EL TECHO  
(D) LASTENTRÄGER AUF DEM DACH ZENTRIEREN  
(F) CENTRER LE PORTE-TOUT SUR LE TOIT  
(NL) PLAATS DE UNIVERSELE DRAGER IN HET MIDDEN VAN HET DAK  
(P) CENTRAR AS BARRAS PORTA BAGAGENS NO TEJADILHO  
(H) HELYEZZE KÖZÉPRE A RUDAKAT  
(PL) WYSRODKOWAC BAGAŻNIK NA DACHU  
(SLO) CENTRIRATI PRTLJAŽNIK NA STREHO  
(HR) CENTRIRATI NOSAČE NA KROV

8

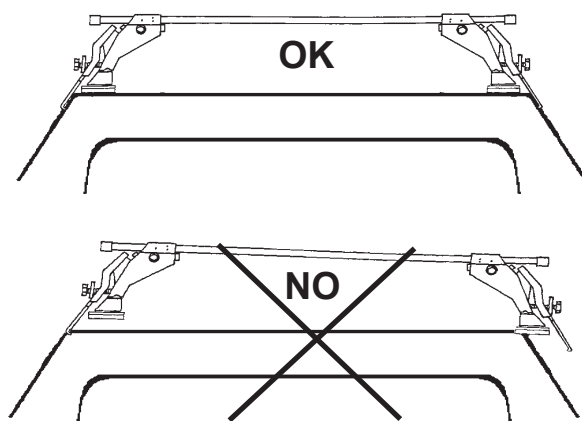

(IT) MODELLI CON PREDISPOSIZIONE DELLA CASA AUTO  
(GB) CARS WITH PRE-EXISTING FIXING POINT FROM MANUFACTURER  
(E) MODELOS CON PREDISPOSICION DEL FABRICANTE  
(D) AUTOS MIT VOM HERSTELLER VORGESEHENE BEFESTIGUNGSPUNKTE  
(F) VOITURES AVEC POINTS DE RÉPÈRE PRÉVUS PAR LE CONSTRUCTEUR  
(NL) AUTO'S MET DOOR DE FABRIKANT VOORZIENE MONTAGEPUNTEN  
(P) VIATURAS COM PONTOS DE FIXAÇÃO DO CONSTRUTOR PRÉ-EXISTENTES  
(H) FELHELYEZÉS GYÁRTÓ ÁLTAL KIJELÖLT PONTRA  
(PL) SAMOCHODY Z PRZEWIDZIANYMI PUNKTAMI UMOCOWANIA  
(SLO) MODELI Z PREDVIDENIM LEŽIŠČEM S STRANI PROIZVAJALCA  
(HR) TVORNIČKI PRIPREMLJENI MODELI

“À TROUVER SUR LE BATTANT DE LA PORTE OU  
DANS LE MANUAL TECHNIQUE DE LA VOITURE “

9

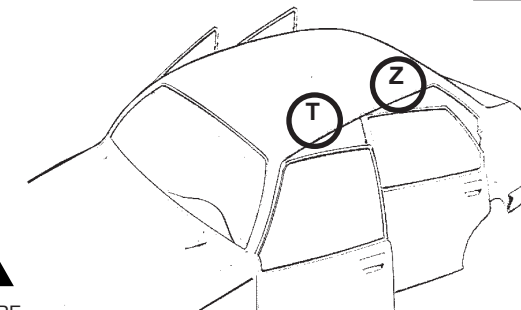

(IT) AVVITARE  
(GB) TO SCREW  
(E) APRETAR  
(D) FESTSCHRAUBEN  
(F) VISSER  
(NL) VASTSCHROEVEN  
(P) APERTAR  
(H) MEGHÚZNI  
(PL) WKRECIĆ  
(SLO) PRIVITI  
(HR) PRIČVRSTITI

(IT) MODELLI AUTO (GB) CARS (E) COCHES (D) WAGEN (F) VOITURES (NL) AUTO (P) MODELO AUTO (H) AUTÓ TIPUS (PL) MODELE SAMOCHODÓW (SLO) MODELI AVTOMOBILOV (HR) MODELI AUTA	(IT) ANTERIORE (GB) FRONT (E) DELANTERO (D) VORDERE (F) AVANT (NL) VOORSTE G. (P) À FRENTE (H) ELSŐ RÚD (PL) PRZOD (SLO) SPREDAJ (HR) PREDNJI	(IT) POSTERIORE (GB) REAR (E) TRASERO (D) HINTERE (F) ARRIERE (NL) ACHTERSTE G. (P) ATRÁS (H) HÁTSÓ RÚD (PL) TYL (SLO) ZADAJ (HR) STRAŽNJI
FIAT Brava 5P (95->01)	T	Z
HONDA Civic VI 5P (94->00)	T	Z
HONDA Concerto 4-5P (88->94)	T	Z
ROVER 45 4-5P (00->05)	T	Z
ROVER 400 4-5P (95->99)	T	Z

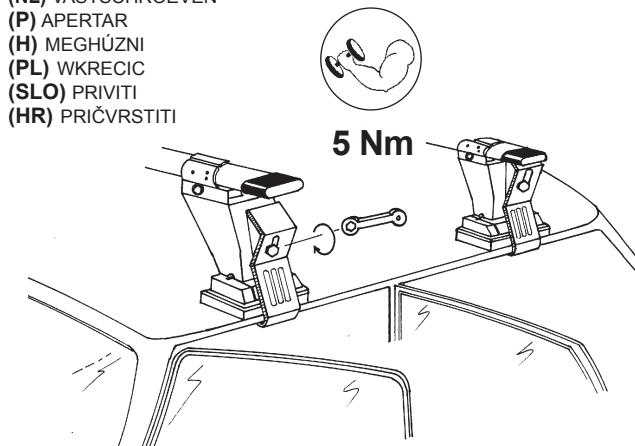

(IT) MODELLI SENZA PREDISPOSIZIONE DELLA CASA AUTO  
(GB) CARS WITHOUT PRE-EXISTING FIXING POINT  
(E) PARA COCHES SIN PREDISPOSICION DEL FABRICANTE  
(D) AUTOS OHNE VOM HERSTELLER VORGESEHENE BEFESTIGUNGSPUNKTE  
(F) VOITURES SANS POINTS DE RÉPÈRE PRÉVUS PAR LE CONSTRUCTEUR  
(NL) AUTO'S ZONDER DOOR DE FABRIKANT VOORZIENE BEVESTIGINGSPUNTEN  
(P) VIATURAS SEM PONTOS DE FIXAÇÃO DO CONSTRUTOR PRÉ-EXISTENTES  
(H) FELHELYEZÉS GYÁRI JELÖLÉS NÉLKÜLI AUTÓKRA  
(PL) SAMOCHODY BEZ PRZEWIDZIANYCH PUNKTOW UMOCOWANIA  
(SLO) MODELI Z NEPREDVIDENIM LEŽIŠČEM S STRANI PROIZVAJALCA  
(HR) TVORNIČKI NEPRIPREMLJENI MODELI

10

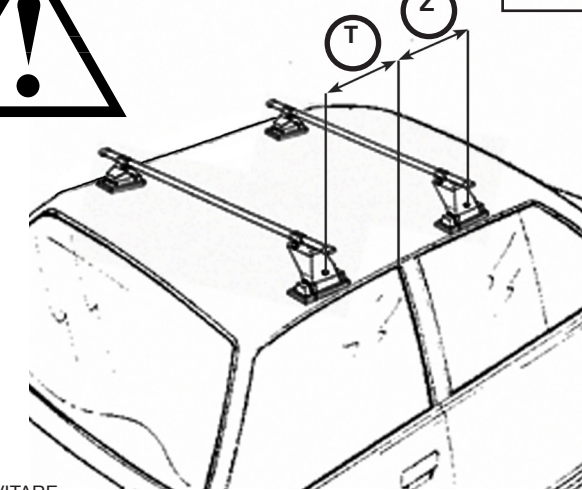

(IT) AVVITARE  
(GB) TO SCREW  
(E) APRETAR  
(D) FESTSCHRAUBEN  
(F) VISSER  
(NL) VASTSCHROEVEN  
(P) APERTAR  
(H) MEGHÚZNI  
(PL) WKRECIĆ  
(SLO) PRIVITI  
(HR) PRIČVRSTITI

(IT) MODELLI AUTO (GB) CARS (E) COCHES (D) WAGEN (F) VOITURES (NL) AUTO (P) MODELO AUTO (H) AUTÓ TIPUS (PL) MODELE SAMOCHODÓW (SLO) MODELI AVTOMOBILOV (HR) MODELI AUTA	(IT) ANTERIORE (GB) FRONT (E) DELANTERO (D) VORDERE (F) AVANT (NL) VOORSTE G. (P) À FRENTE (H) ELSŐ RÚD (PL) PRZOD (SLO) SPREDAJ (HR) PREDNJI	(IT) POSTERIORE (GB) REAR (E) TRASERO (D) HINTERE (F) ARRIERE (NL) ACHTERSTE G. (P) ATRÁS (H) HÁTSÓ RÚD (PL) TYL (SLO) ZADAJ (HR) STRAŽNJI
ALFA ROMEO 166 4P (98->07)	T (250 mm)	Z (350 mm)
BMW Serie 3 Coupè 3P (92->99)	T (350 mm)	Z (350 mm)
CITROËN C1 I 5P (05->14)	T (200 mm)	Z (400 mm)
CITROËN C1 II 5P (14->)	T (270 mm)	Z (410 mm)
FIAT Marea 4P (96->07)	T (170 mm)	Z (430 mm)
FIAT Panda II 5P (03->12) No rails/ Ohne reling	T (200 mm)	Z (500 mm)
HYUNDAI Getz 5P (02->09)	T (300 mm)	Z (400 mm)
HYUNDAI i10 5P (07->13)	T (200 mm)	Z (400 mm)
MAZDA 2 I 5P (04->07)	T (250 mm)	Z (450 mm)
PEUGEOT 107 5P (05->14)	T (200 mm)	Z (400 mm)
PEUGEOT 108 5P (14->) (No versio- ne TOP!)/(No TOP! version)/(keine TOP! Version)/(Non version TOP!)	T (270 mm)	Z (410 mm)
SKODA Felicia I 4P (94->97)	T (350 mm)	Z (350 mm)
SKODA Felicia II 4P (98->01)	T (300 mm)	Z (300 mm)
TOYOTA Aygo I 5P (05->14)	T (200 mm)	Z (400 mm)
TOYOTA Aygo II 5P (14->)	T (270 mm)	Z (410 mm)
VOLKSWAGEN Golf II 3-5P (83->92)	T (300 mm)	Z (400 mm)

