

(IT) MODELLI CON PREDISPOSIZIONE DELLA CASA AUTO
 (GB) CARS WITH PRE-EXISTING FIXING POINT FROM MANUFACTURER
 (E) MODELOS CON PREDISPOSICION DEL FABRICANTE
 (D) AUTOS MIT VOM HERSTELLER VORGESEHENE BEFESTIGUNGSPUNKTE
 (F) VOITURES AVEC POINTS DE RÉPÈRE PREVUS PAR LE CONSTRUCTEUR
 (NL) AUTO'S MET DOOR DE FABRIKANT VOORZIENE MONTAGEPUNTEN
 (P) VIATURAS COM PONTOS DE FIXAÇÃO DO CONSTRUTOR PRÉ-EXISTENTES
 (H) FELHÉLYEZÉS GYÁRTÓ ÁLTAL KIJELÖLT PONTRA
 (PL) SAMOCHODY Z PRZEWIDZIANYMI PUNKTAMI UMOCOWANIA
 (SLO) MODELI Z PREDVIDENIM LEŽIŠČEM S STRANI PROIZVAJALCA
 (HR) TVORNIČKI PRIPREMLJENI MODELI

"À TROUVER SUR LE BATTANT DE LA PORTE OU
 DANS LE MANUAL TECHNIQUE DE LA VOITURE "

11

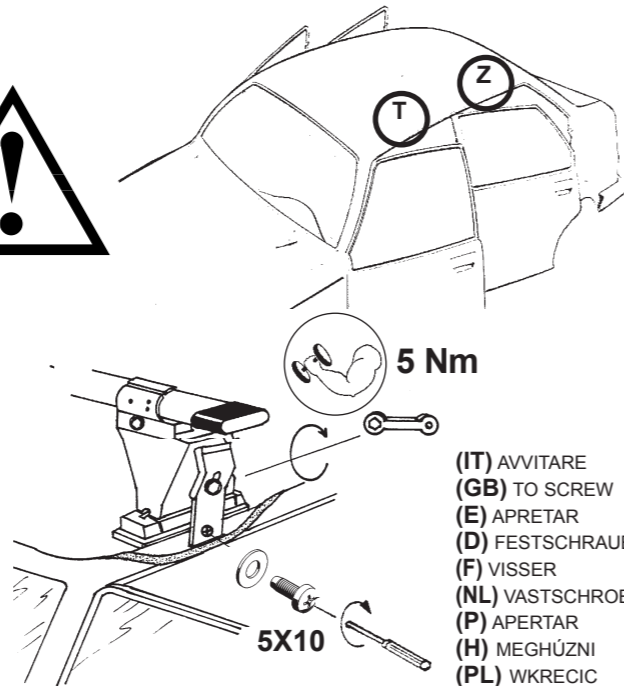

(IT) MODELLI AUTO (GB) CARS (E) COCHES (D) WAGEN (F) VOITURES (NL) AUTO (P) MODELO AUTO (H) AUTÓ TIPUS (PL) MODELE SAMOCHODÓW (SLO) MODELI AVTOMOBILOV (HR) MODELI AUTA	(IT) ANTERIORE (GB) FRONT (E) DELANTERO (D) VORDERE (F) AVANT (NL) VOORSTE G. (P) À FRENTE (H) ELSŐ RÚD (PL) PRZOD (SLO) SPREDAJ (HR) PREDNJI	(IT) POSTERIORE (GB) REAR (E) TRASERO (D) HINTERE (F) ARRIERE (NL) ACHTERSTE G. (P) ATRÁS (H) HÁTSÓ RÚD (PL) TYL (SLO) ZADAJ (HR) STRAŽNJI
---	---	--

NISSAN Qashqai I SUV (07>14) No rails/Ohne reling	T	Z
---	---	---

(IT) MODELLI CON PREDISPOSIZIONE DELLA CASA AUTO
 (GB) CARS WITH PRE-EXISTING FIXING POINT FROM MANUFACTURER
 (E) MODELOS CON PREDISPOSICION DEL FABRICANTE
 (D) AUTOS MIT VOM HERSTELLER VORGESEHENE BEFESTIGUNGSPUNKTE
 (F) VOITURES AVEC POINTS DE RÉPÈRE PREVUS PAR LE CONSTRUCTEUR
 (NL) AUTO'S MET DOOR DE FABRIKANT VOORZIENE MONTAGEPUNTEN
 (P) VIATURAS COM PONTOS DE FIXAÇÃO DO CONSTRUTOR PRÉ-EXISTENTES
 (H) FELHÉLYEZÉS GYÁRTÓ ÁLTAL KIJELÖLT PONTRA
 (PL) SAMOCHODY Z PRZEWIDZIANYMI PUNKTAMI UMOCOWANIA
 (SLO) MODELI Z PREDVIDENIM LEŽIŠČEM S STRANI PROIZVAJALCA
 (HR) TVORNIČKI PRIPREMLJENI MODELI

"À TROUVER SUR LE BATTANT DE LA PORTE OU
 DANS LE MANUAL TECHNIQUE DE LA VOITURE "

12

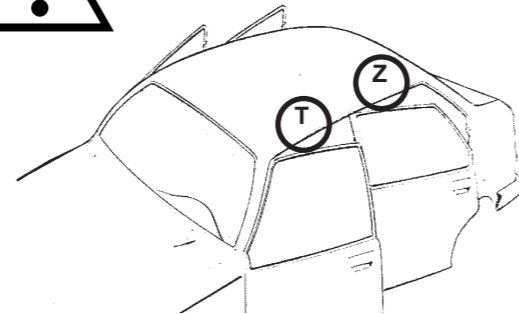

(IT) MODELLI AUTO (GB) CARS (E) COCHES (D) WAGEN (F) VOITURES (NL) AUTO (P) MODELO AUTO (H) AUTÓ TIPUS (PL) MODELE SAMOCHODÓW (SLO) MODELI AVTOMOBILOV (HR) MODELI AUTA	(IT) ANTERIORE (GB) FRONT (E) DELANTERO (D) VORDERE (F) AVANT (NL) VOORSTE G. (P) À FRENTE (H) ELSŐ RÚD (PL) PRZOD (SLO) SPREDAJ (HR) PREDNJI	(IT) POSTERIORE (GB) REAR (E) TRASERO (D) HINTERE (F) ARRIERE (NL) ACHTERSTE G. (P) ATRÁS (H) HÁTSÓ RÚD (PL) TYL (SLO) ZADAJ (HR) STRAŽNJI
---	---	--

RENAULT Grand Scenic III MPV (09>16) 7 posti/7 seats/7 Sitzer/7 places	T	Z
RENAULT Megane III 5P (08>16)	T	Z
RENAULT Scenic III / Scenic III X-MOD MPV (09>16) 5 posti/no rail/5 seats/no rails/5 Sitzer/ohne Railing/5 places/sauf railing	T	Z

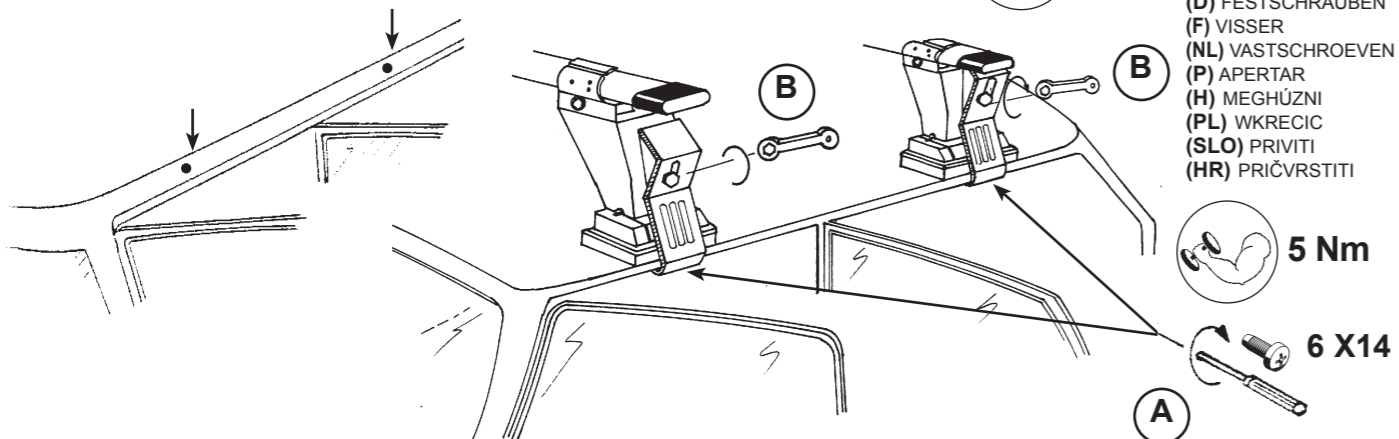

24008/1

Conformes aux essais statiques de la norme ISO/PAS 11154 (09/2007) - NFR 18-903-1 et DIN 75302 contresignés de la marque "GS"

8

(IT) ISTRUZIONI DI MONTAGGIO (GB) FITTING INSTRUCTIONS (E) INSTRUCCIONES PARA SU MONTAJE
 (D) MONTAGEANWEISUNGEN (F) INSTRUCTIONS DE MONTAGE (NL) MONTAGE INSTRUCTIES (P) INSTRUÇÕES DE MONTAGEM
 (H) SZERELÉSI UTASÍTÁS (PL) INSTRUKCJA MONTAZU (SLO) NAVODILA O MONTAŽI (HR) UPUTE ZA MONTAŽU.

1

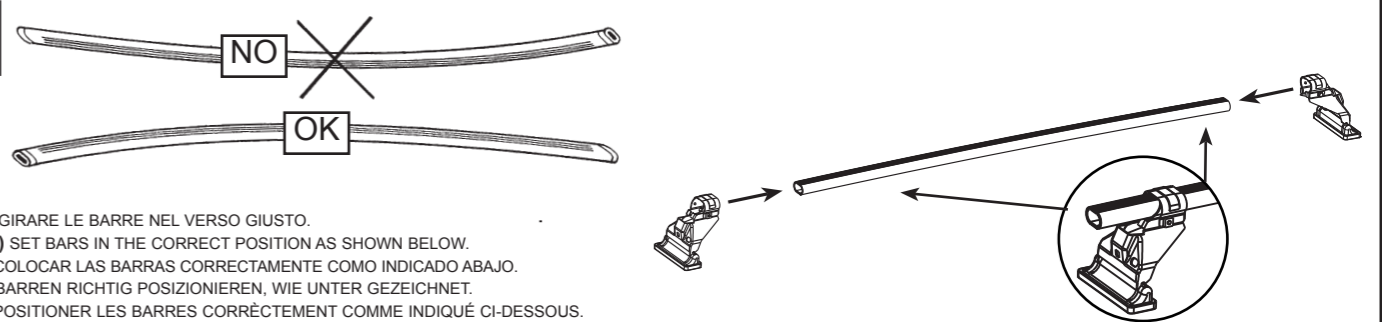

(IT) GIRARE LE BARRE NEL VERSO GIUSTO.
 (GB) SET BARS IN THE CORRECT POSITION AS SHOWN BELOW.
 (E) COLOCAR LAS BARRAS CORRECTAMENTE COMO INDICADO ABAJO.
 (D) BARREN RICHTIG POSITIONIEREN, WIE UNTER GEZEICHNET.
 (F) POSITIONNER LES BARRES CORRÈCTEMENT COMME INDIQUÉ CI-DESSOUS.
 (NL) PLAATS DE DRAGER IN DE JUISTE POSITIE, ZOALS HIERONDER AANGEGEVEN.
 (P) COLOCAR AS BARRAS, COMO INDICADO ABAIXO.
 (H) FORDÍTSÁ A HELYES POZÍCIÓBA.
 (PL) UMIĘCIĆ ZESTAW BELEK WE WIAŚCIWEJ POZYCJI JAK POKAZANO PONIZEJ.
 (SLO) NAMESTITI PREČKE V POZICIJO, KOT JE PRIKAZANO SPODAJ.
 (HR) NAMJESTITI ŠIPKE U PRAVLINU POZICIJU, KAKO JE PRIKAZANO NA SLICI ISPOD.

2

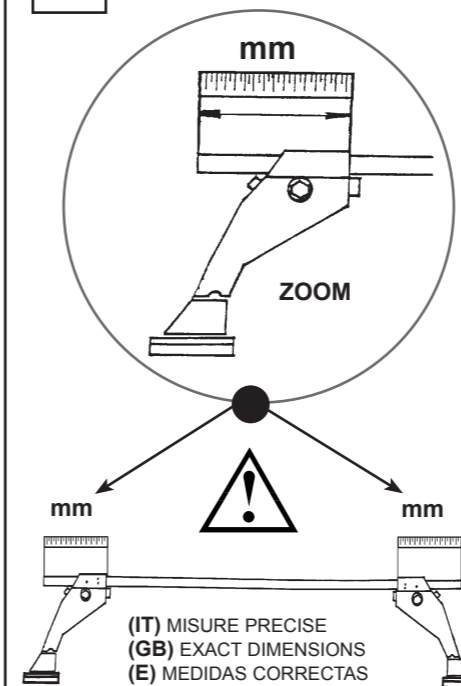

(IT) MISURE PRECISE
 (GB) EXACT DIMENSIONS
 (E) MEDIDAS CORRECTAS
 (D) GENAUE MASSE
 (F) MESURES EXACTES
 (NL) EXACTE AFMETINGEN
 (P) MEDIDAS PRECISAS
 (H) PONTOS MÉRET
 (PL) DOKŁADNE WYMIARY
 (SLO) TOČNE MERE
 (HR) PRECIZNE MJERE

(IT) MODELLI AUTO (GB) CARS (E) COCHES (D) WAGEN (F) VOITURES	(NL) AUTO (P) MODELO AUTO (H) AUTÓ TIPUS (PL) MODELE SAMOCHODÓW (SLO) MODELI AVTOMOBILOV (HR) MODELI AUTA	(IT) ANTERIORE (GB) FRONT (E) DELANTERO (D) VORDERE (F) AVANT	(NL) VOORSTE G. (P) À FRENTE (H) ELSŐ RÚD (PL) PRZOD (SLO) SPREDAJ (HR) PREDNJI	(IT) POST. (GB) REAR (E) TRASERO (D) HINTERE (F) ARRIERE	(NL) ACHTERSTE G. (P) ATRÁS (H) HÁTSÓ RÚD (PL) TYL (SLO) ZADAJ (HR) STRAŽNJI
ALFA ROMEO 75 4P (85>92)		128 mm			143 mm
BMW Serie 5 4P (88>95)		136 mm			136 mm
BMW Serie 5 4P (96>03)		148 mm			148 mm
DAIHATSU Cuore VI 5P (03>06)		173 mm			167 mm
HONDA Jazz II MPV (08>15) Con e senza tetto in vetro /With-w/o sun roof/Mit und ohne Glasdach/ Avec et sauf toit en verre		134 mm			157 mm
HYUNDAI Accent III 5P (06>10)		138 mm			154 mm
HYUNDAI Atos Prime 5P (99>08) No rails/Ohne reling		163 mm			164 mm
KIA Picanto I 5P (04>10)		171 mm			158 mm
LEXUS IS 200 4P (99>05)		143 mm			143 mm
MERCEDES 190 4P (82>93)		143 mm			153 mm
MERCEDES 200 4P (85>95)		121 mm			121 mm
MERCEDES Classe C 4P (93>00)		131 mm			143 mm
MERCEDES Classe C 4P (00>07)		133 mm			144 mm
MERCEDES Classe E 4P (95>01)		118 mm			118 mm
MERCEDES Classe E 4P (02>08)		122 mm			136 mm
NISSAN Qashqai I SUV (07>14) No rails/Ohne reling		84 mm			90 mm
RENAULT Grand Scenic III MPV (09>16) 7 posti/7 seats/7 Sitzer/7 places		88 mm			93 mm
RENAULT Laguna I 4P (94>00)		156 mm			171 mm
RENAULT Megane III 5P (08>16)		136 mm			149 mm
RENAULT Scenic III / Scenic III X-MOD MPV (09>16) 5 posti/no rail/5 seats/no rails/5 Sitzer/ohne Railing/5 places/sauf railing		88 mm			93 mm
SKODA Superb I 4P (02>07)		141 mm			141 mm
TOYOTA Avensis 4P (98>02)		173 mm			173 mm
TOYOTA Avensis 5P (98>02)		173 mm			173 mm
TOYOTA Avensis 4P (03>08)		122 mm			128 mm
TOYOTA Avensis 5P (03>08)		122 mm			128 mm
TOYOTA Carina E 4P (92>98)		158 mm			174 mm
TOYOTA Carina E 5P (92>98)		158 mm			174 mm
TOYOTA Corolla Verso MPV (01>04) No rails/Ohne reling		127 mm			133 mm

3

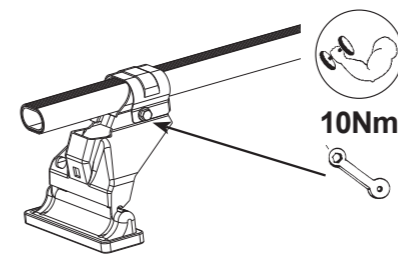

(IT) AVVITARE (A FONDO)
 (GB) TO SCREW (DOWN)
 (E) APRETAR (A FONDO)
 (D) FESTSCHRAUBEN
 (F) VISSER (À FOND)
 (NL) VASTSCHROEVEN
 (P) APERTAR POR BAIXO
 (H) MEGHÚZNI
 (PL) WKRECIC DO KONCA
 (SLO) PRIVITI (DO KONCA)
 (HR) PRIČVRSTITI (DO KRAJA)

IST_24008_01_1911

4

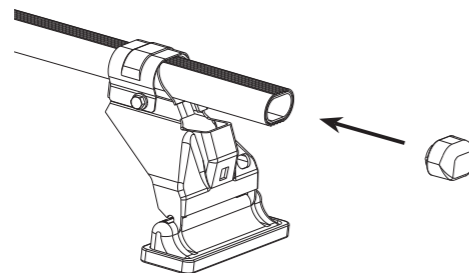

(IT) INSERIRE
(GB) INSERT
(E) CUBRIR
(D) STOPFEN
(F) ENFILER
(NL) BEVESTIG
(P) INSERIR
(H) TOLJA FEL
(PL) NALOZIC
(SLO) VSTAVITI
(HR) PREKRITI

(IT) MODELLI AUTO (GB) CARS (E) COCHES (D) WAGEN (F) VOITURES (NL) AUTO (P) MODELO AUTO (H) AUTÓ TIPUS (PL) MODELE SAMOCHODÓW (SLO) MODELI AVTOMOBILOV (HR) MODELI AVTA	(IT) ANTERIORE (GB) FRONT (E) DELANTERO (D) VORDERE (F) AVANT (NL) VOORSTE G. (P) À FRENTE (H) ELSŐ RÜD (PL) PRZOD (SLO) SPREDAJ (HR) PREDNJI	(IT) POSTERIORE (GB) REAR (E) TRASERO (D) HINTERE (F) ARRIERE (NL) ACHTERSTE G. (P) ATRÁS (H) HÁTSÓ RÜD (PL) TYL (SLO) ZADAJ (HR) STRAŽNJI
--	---	---

ALFA ROMEO 75 4P (85>92)	7	7
BMW Serie 5 4P (88>95)	7	7
BMW Serie 6 4P (96>03)	7	7
DAIHATSU Cuore VI 5P (03>06)	7	7
HONDA Jazz II MPV (08>15) Con e senza tetto in vetro /With-w/o sun roof/Mit und ohne Glasdach/ Avec et sauf toit en verre	7	7
HYUNDAI Accent III 5P (06>10)	7	7
HYUNDAI Atos Prime 5P (99>08) No rails/Ohne reling	7	7
KIA Picanto I 5P (04>10)	7	7
LEXUS IS 200 4P (99>05)	7	7
MERCEDES 190 4P (82>93)	7	7
MERCEDES 200 4P (85>95)	7	7
MERCEDES Classe C 4P (93>00)	7	7
MERCEDES Classe C 4P (00>07)	7	7
MERCEDES Classe E 4P (95>01)	7	7
MERCEDES Classe E 4P (02>08)	7	7
NISSAN Qashqai I SUV (07>14) No rails/Ohne reling	123	123
RENAULT Grand Scenic III MPV (09>16) 7 posti/7 seats/7 Sitzer/7 places	108	108
RENAULT Laguna I 4P (94>00)	7	7
RENAULT Megane III 5P (08>16)	108	108
RENAULT Scenic III / Scenic III X-MOD MPV (09>16) 5 posti/no rail/5 seats/no rails/5 Sitzer/ ohne Reling/5 places/sauf railing	108	108
SKODA Superb I 4P (02>07)	7	7
TOYOTA Avensis 4P (98>02)	7	7
TOYOTA Avensis 5P (98>02)	7	7
TOYOTA Avensis 4P (03>08)	7	7
TOYOTA Avensis 5P (03>08)	7	7
TOYOTA Carina E 4P (92>98)	7	7
TOYOTA Carina E 5P (92>98)	7	7
TOYOTA Corolla Verso MPV (01>04) No rails/ Ohne reling	7	7

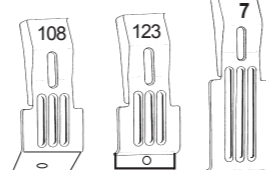

5



(IT) MONTAGGIO GANASCINE
(GB) HOW TO ASSEMBLE THE CLAMPS
(E) COMO MONTAR LAS FIJACIONES
(D) ZUSAMMENBAU DER SPANNBACKEN
(F) MONTAGE PATTE
(NL) MONTAGE VAN DE KLEMMEN
(P) COMO FIXAR OS SUPORTES
(H) RÖGZITŐ FÜLEK
(PL) MONTAZ SZCZEK MOCUJACYCH
(SLO) MONTAŽA NAPENJALNIKA
(HR) MONTAŽA ČELJUSTI

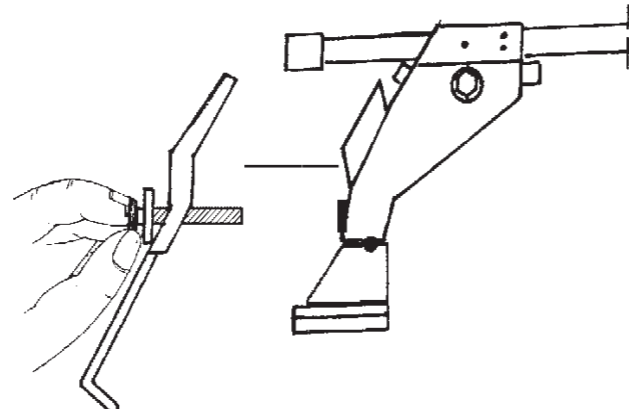

6

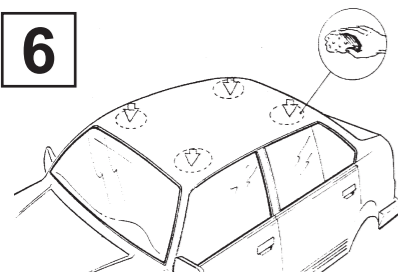

(IT) PULIRE IL TETTO
(GB) CLEAN THE ROOF
(E) LIMPIAR EL TECHO
(D) DACH REINIGEN
(F) NETTOYER LE TOIT
(NL) DAK SCHOONMAKEN
(P) LIMPAR O TEJADILHO
(H) TISZTÍTSA MEG A TETŐT
(PL) WYCZYSCIC DACH
(SLO) OČISTITI STREHO
(HR) ČIŠTENJE KROVA

7

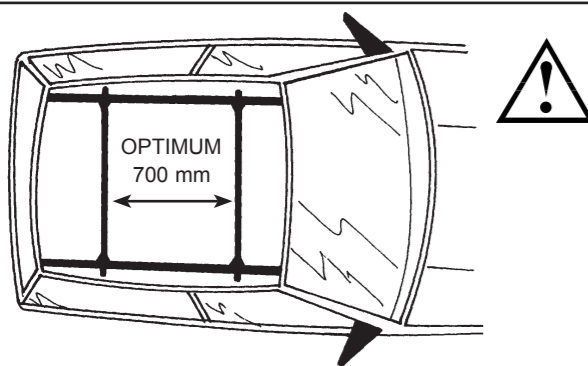

(IT) CENTRARE IL P. TUTTO SUL TETTO
(GB) CENTRE THE UNIVERSAL BAR CARRIER ON THE ROOF
(E) CENTRAR EL PORTAEQUIPAJES SOBRE EL TECHO
(D) LASTENTRÄGER AUF DEM DACH ZENTRIEREN
(F) CENTRER LE PORTE-TOUT SUR LE TOIT
(NL) PLAATS DE UNIVERSELE DRAGER IN HET MIDDEN VAN HET DAK
(P) CENTRAR AS BARRAS PORTA BAGAGENS NO TEJADILHO
(H) HELYEZZE KÖZÉPRE A RUDAKAT
(PL) WYSRODKOWAC BAGAŻNIK NA DACHU
(SLO) CENTRIRATI PRTLJAŽNIK NA STREHO
(HR) CENTRIRATI NOSAČE NA KROV

8

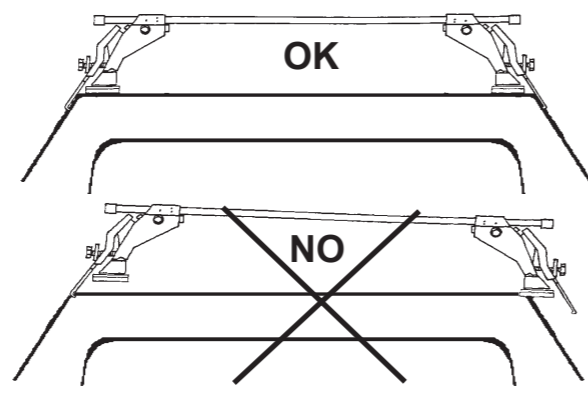

(IT) MODELLI CON PREDISPOSIZIONE DELLA CASA AUTO
(GB) CARS WITH PRE-EXISTING FIXING POINT FROM MANUFACTURER
(E) MODELOS CON PREDISPOSICION DEL FABRICANTE
(D) AUTOS MIT VOM HERSTELLER VORGESEHENE BEFESTIGUNGSPUNKTE
(F) VOITURES AVEC POINTS DE RÉPÈRE PRÉVUS PAR LE CONSTRUCTEUR
(NL) AUTO'S MET DOOR DE FABRIKANT VOORZIENE MONTAGEPUNTEN
(P) VIATURAS COM PONTOS DE FIXAÇÃO DO CONSTRUTOR PRÉ-EXISTENTES
(H) FELHELYEZÉS GYÁRTÓ ÁLTAL KIJELÖLT PONTRA
(PL) SAMOCHODY Z PRZEWIDZIANYMI PUNKTAMI UMOCOWANIA
(SLO) MODELI Z PREDVIDENIM LEŽIŠČEM S STRANI PROIZVAJALCA
(HR) TVORNIČKI PRIPREMLJENI MODELI

“À TROUVER SUR LE BATTANT DE LA PORTE OU DANS LE MANUAL TECHNIQUE DE LA VOITURE “

9

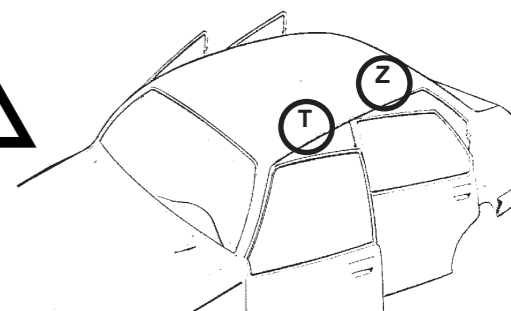

(IT) AVVITARE
(GB) TO SCREW
(E) APRETAR
(D) FESTSCHRAUBEN
(F) VISSER
(NL) VASTSCHROEVEN
(P) APERTAR
(H) MEGHÚZNI
(PL) WKRECIĆ
(SLO) PRIVITI
(HR) PRIČVRSTITI



5 Nm

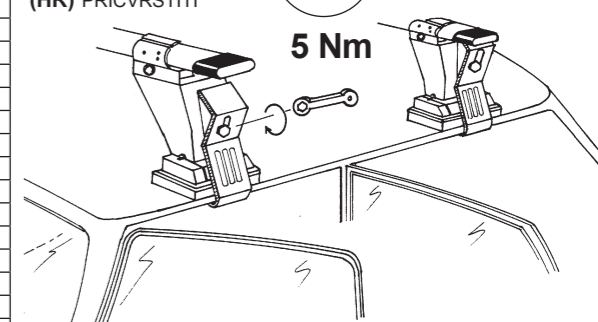

(IT) MODELLI AUTO (GB) CARS (E) COCHES (D) WAGEN (F) VOITURES (NL) AUTO (P) MODELO AUTO (H) AUTÓ TIPUS (PL) MODELE SAMOCHODÓW (SLO) MODELI AVTOMOBILOV (HR) MODELI AVTA	(IT) ANTERIORE (GB) FRONT (E) DELANTERO (D) VORDERE (F) AVANT (NL) VOORSTE G. (P) À FRENTE (H) ELSŐ RÜD (PL) PRZOD (SLO) SPREDAJ (HR) PREDNJI	(IT) POSTERIORE (GB) REAR (E) TRASERO (D) HINTERE (F) ARRIERE (NL) ACHTERSTE G. (P) ATRÁS (H) HÁTSÓ RÜD (PL) TYL (SLO) ZADAJ (HR) STRAŽNJI
--	---	---

HONDA Jazz II MPV (08>15) Con e senza tetto in vetro /With-w/o sun roof/Mit und ohne Glasdach/ Avec et sauf toit en verre	T	Z
HYUNDAI Accent III 5P (06>10)	T	Z
LEXUS IS 200 4P (99>05)	T	Z
MERCEDES 190 4P (82>93)	T	Z
MERCEDES 200 4P (85>95)	T	Z
MERCEDES Classe C 4P (93>00)	T	Z
MERCEDES Classe E 4P (95>01)	T	Z
RENAULT Laguna I 4P (94>00)	T	Z
SKODA Superb I 4P (02>07)	T	Z
TOYOTA Avensis 4P (98>02)	T	Z
TOYOTA Avensis 5P (98>02)	T	Z
TOYOTA Avensis 4P (03>08)	T	Z
TOYOTA Avensis 5P (03>08)	T	Z
TOYOTA Carina E 4P (92>98)	T	Z
TOYOTA Carina E 5P (92>98)	T	Z
TOYOTA Corolla Verso MPV (01>04) No rails/ Ohne reling	T	Z

(IT) MODELLI SENZA PREDISPOSIZIONE DELLA CASA AUTO
(GB) CARS WITHOUT PRE-EXISTING FIXING POINT
(E) PARA COCHES SIN PREDISPOSICION DEL FABRICANTE
(D) AUTOS OHNE VOM HERSTELLER VORGESEHENE BEFESTIGUNGSPUNKTE
(F) VOITURES SANS POINTS DE RÉPÈRE PRÉVUS PAR LE CONSTRUCTEUR
(NL) AUTO'S ZONDER DOOR DE FABRIKANT VOORZIENE BEVESTIGINGSPUNTEN
(P) VIATURAS SEM PONTOS DE FIXAÇÃO DO CONSTRUTOR PRÉ-EXISTENTES
(H) FELHELYEZÉS GYÁRI JELÖLÉS NÉLKÜLI AUTÓKRA
(PL) SAMOCHODY BEZ PRZEWIDZIANYCH PUNKTOW UMOCOWANIA
(SLO) MODELI Z NEPREDVIDENIM LEŽIŠČEM S STRANI PROIZVAJALCA
(HR) TVORNIČKI NEPRIPREMLJENI MODELI

10

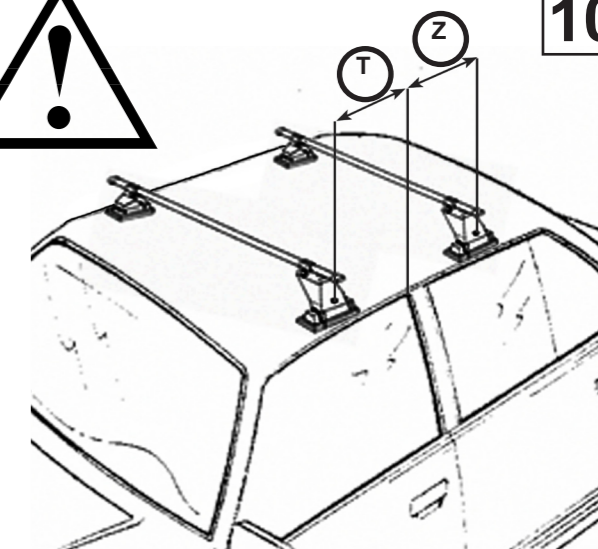

(IT) AVVITARE
(GB) TO SCREW
(E) APRETAR
(D) FESTSCHRAUBEN
(F) VISSER
(NL) VASTSCHROEVEN
(P) APERTAR
(H) MEGHÚZNI
(PL) WKRECIĆ
(SLO) PRIVITI
(HR) PRIČVRSTITI



5 Nm

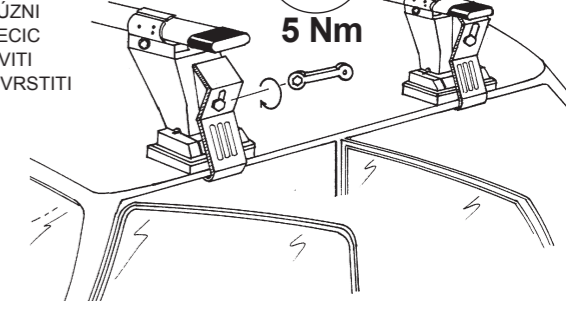

(IT) MODELLI AUTO (GB) CARS (E) COCHES (D) WAGEN (F) VOITURES (NL) AUTO (P) MODELO AUTO (H) AUTÓ TIPUS (PL) MODELE SAMOCHODÓW (SLO) MODELI AVTOMOBILOV (HR) MODELI AVTA	(IT) ANTERIORE (GB) FRONT (E) DELANTERO (D) VORDERE (F) AVANT (NL) VOORSTE G. (P) À FRENTE (H) ELSŐ RÜD (PL) PRZOD (SLO) SPREDAJ (HR) PREDNJI	(IT) POSTERIORE (GB) REAR (E) TRASERO (D) HINTERE (F) ARRIERE (NL) ACHTERSTE G. (P) ATRÁS (H) HÁTSÓ RÜD (PL) TYL (SLO) ZADAJ (HR) STRAŽNJI
--	---	---

ALFA ROMEO 75 4P (85>92)	T = 250 mm	Z = 450 mm
BMW Serie 5 4P (88>95)	T = 350 mm	Z = 350 mm
BMW Serie 6 4P (96>03)	T = 250 mm	Z = 450 mm
DAIHATSU Cuore VI 5P (03>06)	T = 250 mm	Z = 450 mm
HYUNDAI Atos Prime 5P (99>08) No rails/Ohne reling	T = 250 mm	Z = 400 mm
KIA Picanto I 5P (04>10)	T = 250 mm	Z = 500 mm
MERCEDES Classe C 4P (00>07)	T = 200 mm	Z = 300 mm
MERCEDES Classe E 4P (02>08)	T = 230 mm	Z = 370 mm

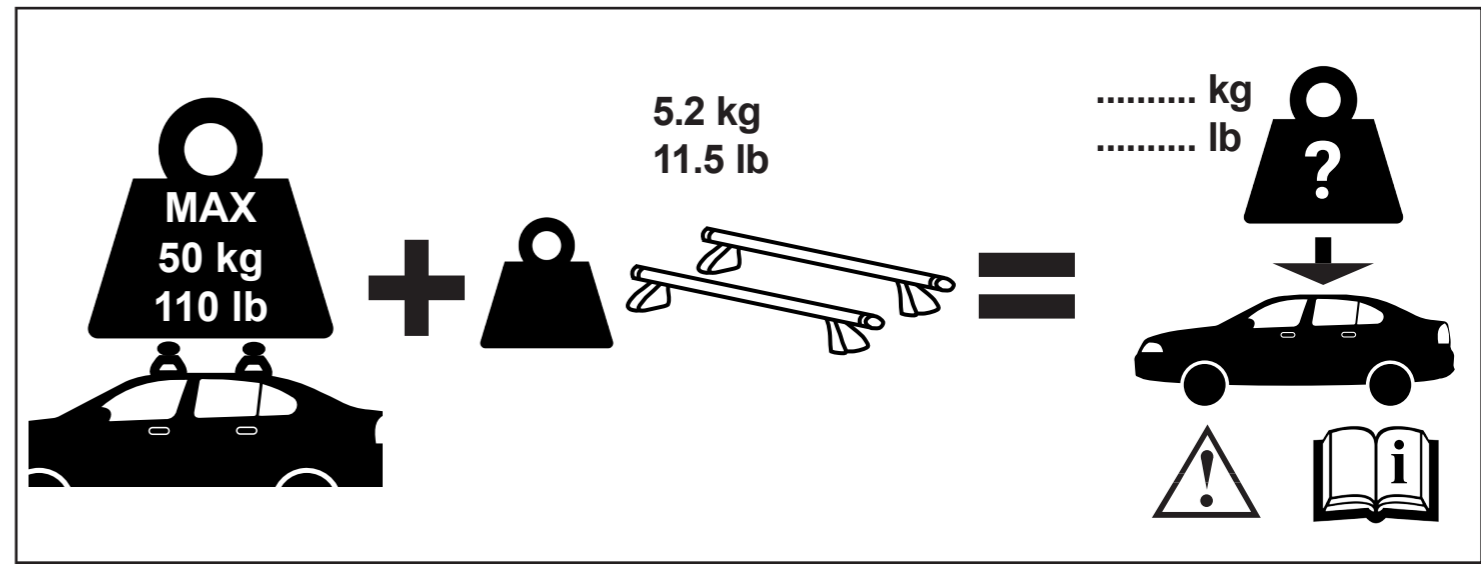

COVER

(IT) ISTRUZIONI DI MONTAGGIO (GB) FITTING INSTRUCTIONS (F) INSTRUCTIONS DE MONTAGE
 (D) MONTAGEANWEISUNGEN (E) INSTRUCCIONES PARA SU MONTAJE (P) INSTRUÇÕES DE MONTAGEM
 (NL) MONTAGE INSTRUCTIES (H) SZERELÉSI UTASÍTÁS (PL) INSTRUKCJA MONTAŻU
 (SLO) NAVODILA ZA MONTAŽO (HR) UPUTSTVO ZA MONTAŽU

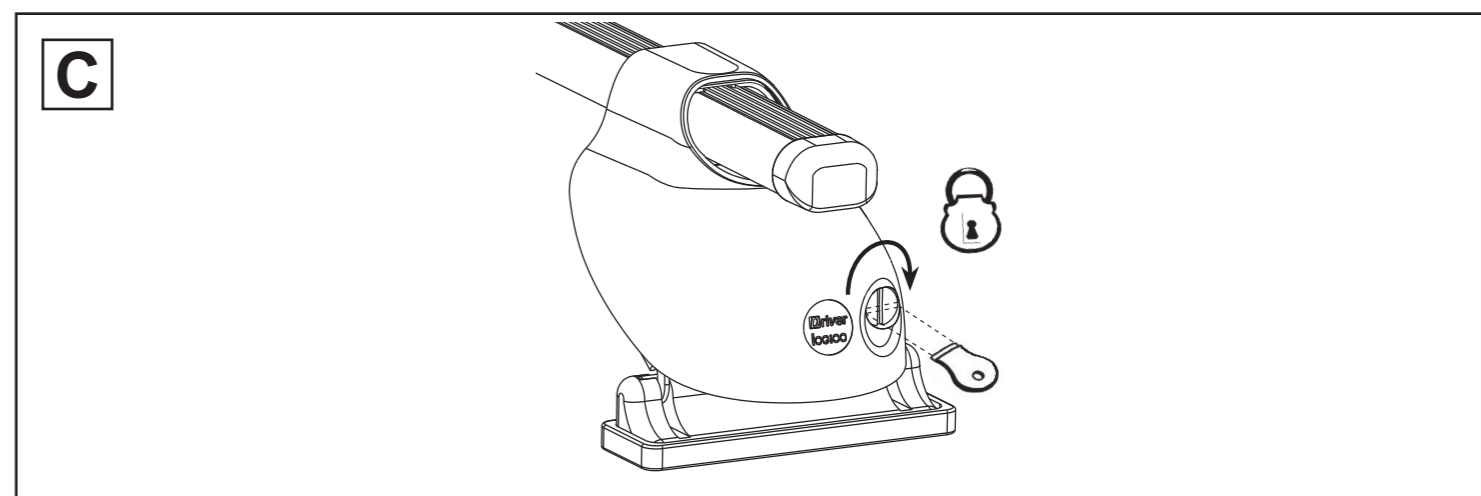
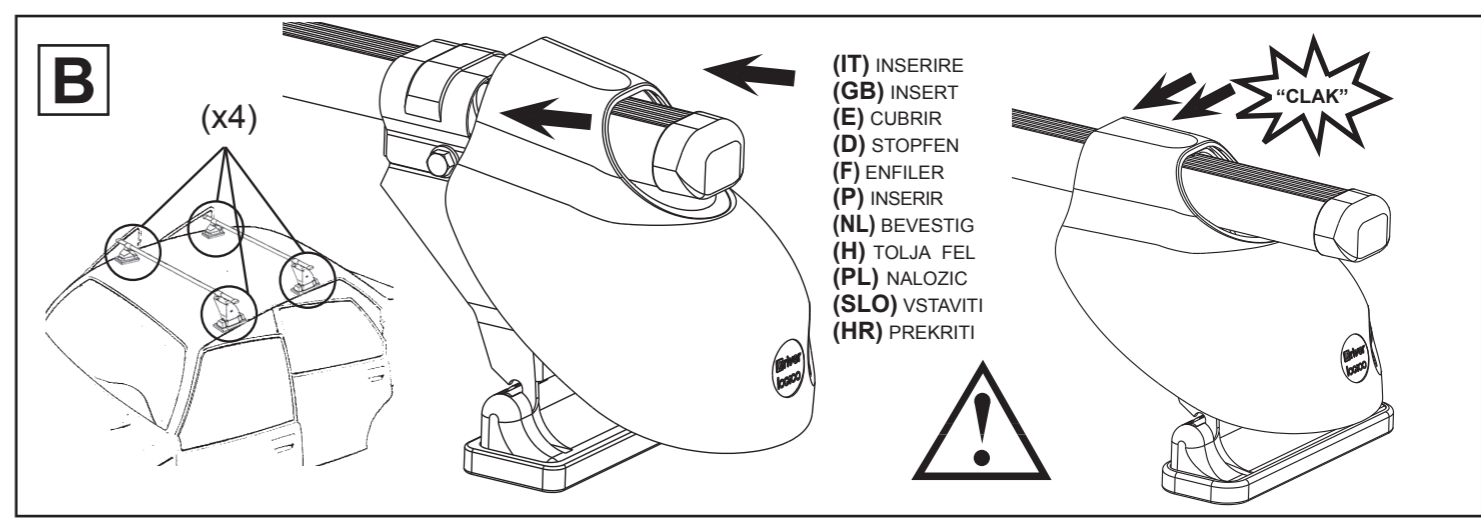
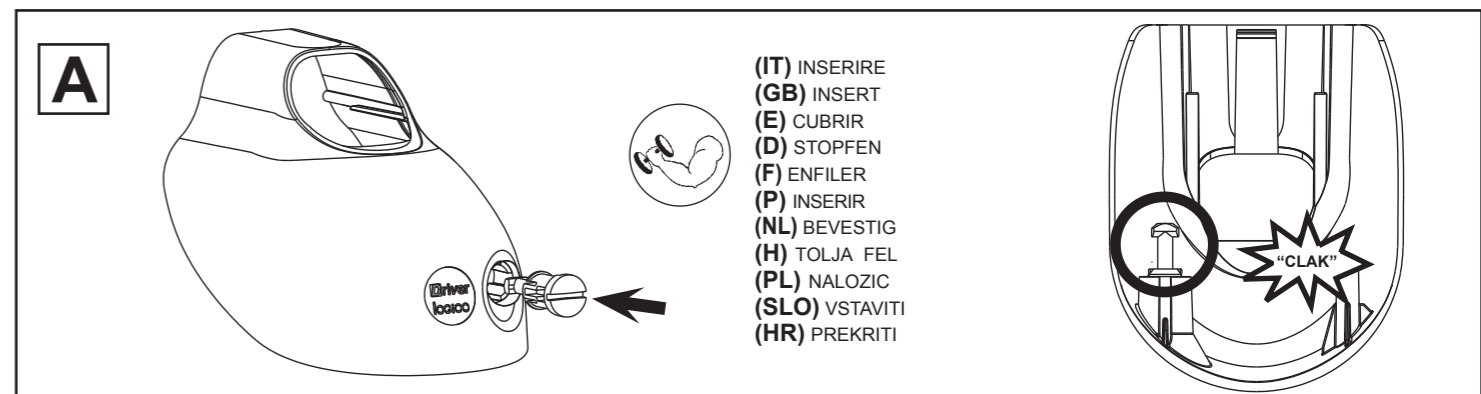

IST_24008_01_1911