

11

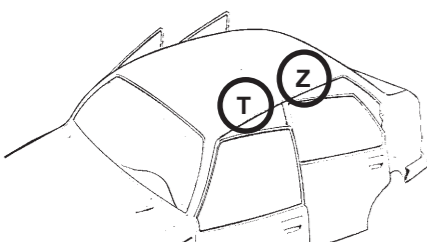

“À TROUVER SUR LE BATTANT DE LA PORTE OU DANS LE MANUAL TECHNIQUE DE LA VOITURE “



(IT) MODELLI CON PREDISPOSIZIONE DELLA CASA AUTO  
 (GB) CARS WITH PRE-EXISTING FIXING POINT FROM MANUFACTURER  
 (E) MODELOS CON PREDISPOSICION DEL FABRICANTE  
 (D) AUTOS MIT VOM HERSTELLER VORGESEHENE BEFESTIGUNGSPUNKTE  
 (F) VOITURES AVEC POINTS DE RÉPÈRE PRÉVUS PAR LE CONSTRUCTEUR  
 (NL) AUTO'S MET DOOR DE FABRIKANT VOORZIENE MONTAGEPUNTEN  
 (P) VIATURAS COM PONTOS DE FIXAÇÃO DO CONSTRUTOR PRÉ-EXISTENTES  
 (H) FELHÉLYEZÉS GYÁRTÓ ÁLTAL KIJELÖLT PONTRA  
 (PL) SAMOCHODY Z PRZEWIDZIANYMI PUNKTAMI UMOCOWANIA  
 (SLO) MODELI Z PREDVIDENIM LEŽIŠČEM S STRANI PROIZVAJALCA  
 (HR) TVORNIČKI PRIPREMLJENI MODELI

(IT) MODELLI AUTO (GB) CARS (E) COCHES (D) WAGEN (F) VOITURES (NL) AUTO (P) MODELO AUTO (H) AUTÓ TIPUS (PL) MODELE SAMOCHODÓW (SLO) MODELI AVTOMOBILOV (HR) MODELI AUTA	(IT) ANTERIORE (GB) FRONT (E) DELANTERO (D) VORDERE (F) AVANT (NL)VOORSTE G. (P) À FRENTE (H) ELSŐ RÚD (PL) PRZOD (SLO) SPREDAJ (HR) PREDNJI	(IT) POSTERIORE (GB) REAR (E) TRASERO (D) HINTERE (F) ARRIERE (NL) ACHTERSTE G. (P) ATRÁS (H) HÁTSÓ RÚD (PL) TYL (SLO) ZADAJ (HR) STRAŽNJI
SEAT Ibiza IV 5P (08->)	T	Z
VOLKSWAGEN Golf V Plus MPV (05->06) No rails	T	Z
VOLKSWAGEN Jetta V 4P (05->10)	T	Z

(IT) ANTERIORE (GB) FRONT (E) DELANTERO (D) VORDERE (F) AVANT (NL)VOORSTE G. (P) À FRENTE (H) ELSŐ RÚD (PL) PRZOD (SLO) SPREDAJ (HR) PREDNJI

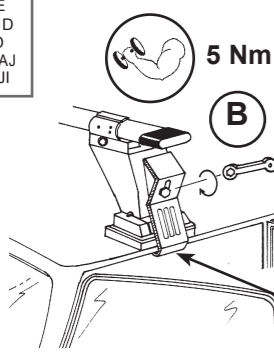

(IT) AVVITARE (GB) TO SCREW (E) APRETAR (D) FESTSCHRAUBEN (F) VISSER (NL) VASTSCHROEVEN (P) APERTAR (H) MEGHÚZNI (PL) WKRECIC (SLO) PRIVITI (HR) PRIČVRSTITI

6 X14

(IT) POSTERIORE (GB) REAR (E) TRASERO (D) HINTERE (F) ARRIERE (NL) ACHTERSTE G. (P) ATRÁS (H) HÁTSÓ RÚD (PL) TYL (SLO) ZADAJ (HR) STRAŽNJI

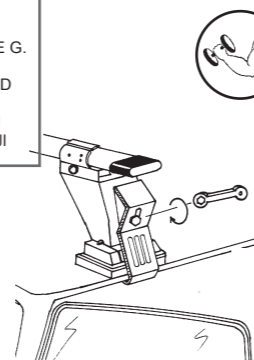

(IT) AVVITARE (GB) TO SCREW (E) APRETAR (D) FESTSCHRAUBEN (F) VISSER (NL) VASTSCHROEVEN (P) APERTAR (H) MEGHÚZNI (PL) WKRECIC (SLO) PRIVITI (HR) PRIČVRSTITI

12

(IT) MODELLI SENZA PREDISPOSIZIONE DELLA CASA AUTO  
 (GB) CARS WITHOUT PRE-EXISTING FIXING POINT  
 (E) PARA COCHES SIN PREDISPOSICION DEL FABRICANTE  
 (D) AUTOS OHNE VOM HERSTELLER VORGESEHENE BEFESTIGUNGSPUNKTE  
 (F) VOITURES SANS POINTS DE RÉPÈRE PRÉVUS PAR LE CONSTRUCTEUR  
 (NL) AUTO'S ZONDER DOOR DE FABRIKANT VOORZIENE BEVESTIGINGSPUNTEN  
 (P) VIATURAS SEM PONTOS DE FIXAÇÃO DO CONSTRUTOR PRÉ-EXISTENTES  
 (H) FELHÉLYEZÉS GYÁRI JELÖLÉS NÉLKÜLI AUTÓKRA  
 (PL) SAMOCHODY BEZ PRZEWIDZIANYCH PUNKTOW UMOCOWANIA  
 (SLO) MODELI Z NEPREDVIDENIM LEŽIŠČEM S STRANI PROIZVAJALCA  
 (HR) TVORNIČKI NEPRIPREMLJENI MODELI

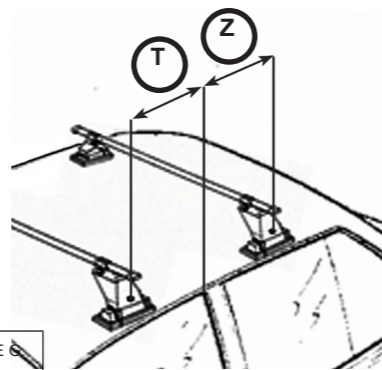

(IT) MODELLI AUTO (GB) CARS (E) COCHES (D) WAGEN (F) VOITURES (NL) AUTO (P) MODELO AUTO (H) AUTÓ TIPUS (PL) MODELE SAMOCHODÓW (SLO) MODELI AVTOMOBILOV (HR) MODELI AUTA	(IT) ANTERIORE (GB) FRONT (E) DELANTERO (D) VORDERE (F) AVANT (NL) VOORSTE G. (P) À FRENTE (H) ELSŐ RÚD (PL) PRZOD (SLO) SPREDAJ (HR) PREDNJI	(IT) POSTERIORE (GB) REAR (E) TRASERO (D) HINTERE (F) ARRIERE (NL) ACHTERSTE G. (P) ATRÁS (H) HÁTSÓ RÚD (PL) TYL (SLO) ZADAJ (HR) STRAŽNJI
NISSAN Micra IV 5P (10>17)	T = 320 mm	Z = 300 mm
TOYOTA Avensis Wagon SW (09->)	T = 220 mm	Z = 480 mm

(IT) AVVITARE (GB) TO SCREW (E) APRETAR (D) FESTSCHRAUBEN (F) VISSER (NL) VASTSCHROEVEN (P) APERTAR (H) MEGHÚZNI (PL) WKRECIC (SLO) PRIVITI (HR) PRIČVRSTITI

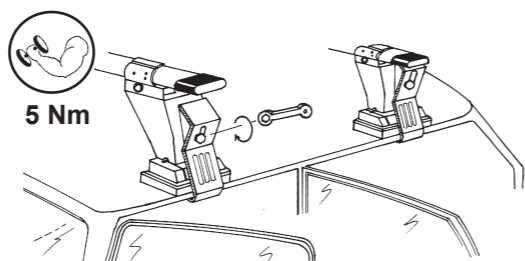

24007/1

Conformes aux essais statiques de la norme ISO/PAS 11154 (09/2007) - NFR 18-903-1 et DIN 75302 contresignés de la marque "GS"

7

(IT) ISTRUZIONI DI MONTAGGIO (GB) FITTING INSTRUCTIONS (E) INSTRUCCIONES PARA SU MONTAJE (D) MONTAGEANWEISUNGEN (F) INSTRUCTIONS DE MONTAGE (NL) MONTAGE INSTRUCTIES (P) INSTRUÇÕES DE MONTAGEM (H) SZERELÉSI UTASÍTÁS (PL) INSTRUKCJA MONTAZU (SLO) NAVODILA O MONTAŽI (HR) UPUTE ZA MONTAŽU.

1

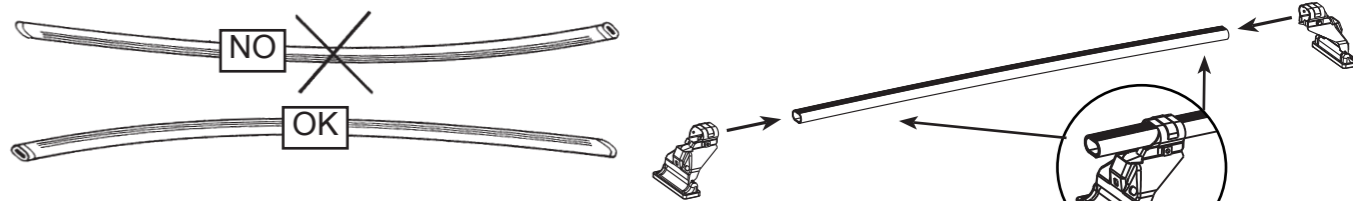

(IT) GIRARE LE BARRE NEL VERSO GIUSTO.  
 (GB) SET BARS IN THE CORRECT POSITION AS SHOWN BELOW.  
 (E) COLOCAR LAS BARRAS CORRECTAMENTE COMO INDICADO ABAJO.  
 (D) BARREN RICHTIG POSITIONIEREN, WIE UNTER GEZEICHNET.  
 (F) POSITIONNER LES BARRES CORRÈCTEMENT COMME INDIQUÉ CI-DESSOUS.  
 (NL) PLAATS DE DRAGER IN DE JUISTE POSITIE, ZOALS HIERONDER AANGEGEVEN.

(P) COLOCAR AS BARRAS, COMO INDICADO ABAIXO.  
 (H) FORDÍTSÁ A HELYES POZÍCIÓBA.  
 (PL) UMIĘŚCIĆ ZESTAW BELEK WE WIAŚCIWEJ POZYCJI JAK POKAZANO PONIEJ.  
 (SLO) NAMESTITI PREČKE V POZICIJO, KOT JE PRIKAZANO SPODAJ.  
 (HR) NAMJESTITI ŠIPKE U PRAVLINU POZICIJU, KAKO JE PRIKAZANO NA SLICI ISPOD.

2

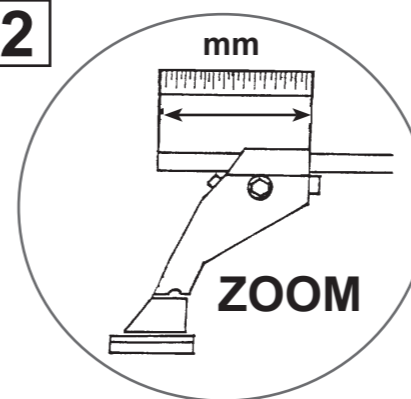

(IT) MISURE PRECISE (GB) EXACT DIMENSIONS (E) MEDIDAS CORRECTAS (D) GENAUUE MASSE (F) MESURES EXACTES (NL) EXACTE AFMETINGEN (P) MEDIDAS PRECISAS (H) PONTOS MÉRET (PL) DOKŁADNE WYMIARY (SLO) TOČNE MERE (HR) PRECIZNE MJERE

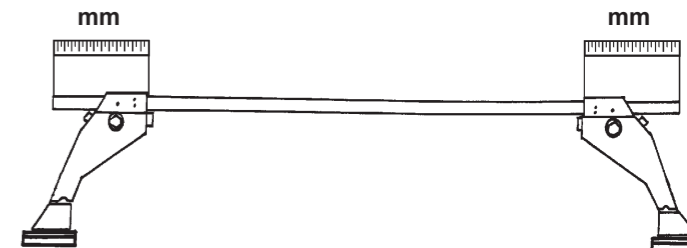

(IT) MODELLI AUTO (GB) CARS (E) COCHES (D) WAGEN (F) VOITURES	(NL) AUTO (P) MODELO AUTO (H) AUTÓ TIPUS (PL) MODELE SAMOCHODÓW (SLO) MODELI AVTOMOBILOV (HR) MODELI AUTA	(IT) ANTERIORE (GB) FRONT (E) DELANTERO (D) VORDERE (F) AVANT (NL)VOORSTE G. (P) À FRENTE (H) ELSŐ RÚD (PL) PRZOD (SLO) SPREDAJ (HR) PREDNJI	(IT) POST. (GB) REAR (E) TRASERO (D) HINTERE (F) ARRIERE (NL) ACHTERSTE G. (P) ATRÁS (H) HÁTSÓ RÚD (PL) TYL (SLO) ZADAJ (HR) STRAŽNJI
FORD Mondeo IV 4P (07>14)		105 mm	117 mm
FORD Mondeo IV 5P (07>14)		108 mm	120 mm
FORD Mondeo IV SW (07>14) No rails/Ohne reling		108 mm	137 mm
LEXUS IS II 4P (05>13)		148 mm	141 mm
NISSAN Micra IV 5P (10>17)		182 mm	195 mm
SEAT Ibiza IV 5P (08>17)		139 mm	154 mm
SKODA Fabia II 5P (07>15)		131 mm	131 mm
SKODA Superb II 4P (08>15)		123 mm	117 mm
SKODA Superb III 4P (15>)		104 mm	118 mm
TOYOTA Avensis Wagon SW (09>18)		116 mm	122 mm
VOLKSWAGEN Golf V 5P (03>09)		124 mm	158 mm
VOLKSWAGEN Golf V Plus MPV (05>06) No rails/Ohne reling		116 mm	128 mm
VOLKSWAGEN Golf V Plus MPV (07>09) No rails/Ohne reling		122 mm	128 mm
VOLKSWAGEN Golf VI 5P (08>12)		124 mm	158 mm
VOLKSWAGEN Jetta V 4P (05>10)		108 mm	121 mm
VOLKSWAGEN Passat VI 4P (05>10)		112 mm	112 mm
VOLKSWAGEN Passat VII 4P (10>14)		112 mm	112 mm
VOLKSWAGEN Polo IV 5P (01>09)		155 mm	172 mm
VOLKSWAGEN Polo V 5P (09>17)		135 mm	151 mm



3

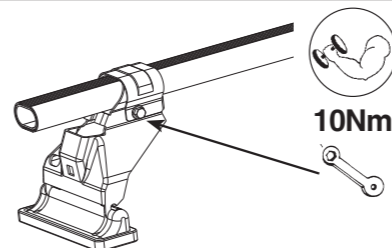

(IT) AVVITARE (A FONDO) (GB) TO SCREW (DOWN) (E) APRETAR (A FONDO) (D) FESTSCHRAUBEN (F) VISSER (À FOND) (NL) VASTSCHROEVEN (P) APERTAR POR BAIXO (H) MEGHÚZNI (PL) WKRECIC DO KONCA (SLO) PRIVITI (DO KONCA) (HR) PRIČVRSTITI (DO KRAJA)

4

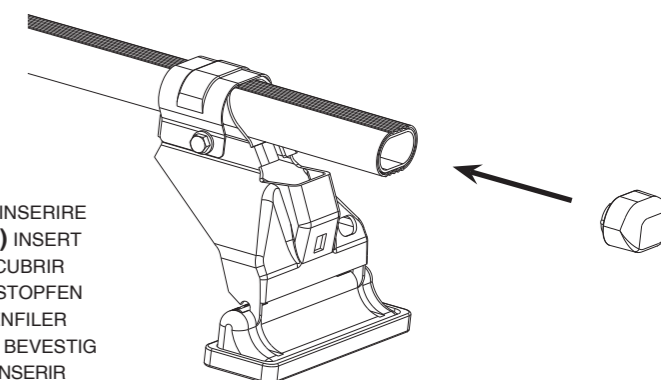

(IT) INSERIRE (GB) INSERT (E) CUBRIR (D) STOPFEN (F) ENFILER (NL) BEVESTIG (P) INSERIR (H) TOLJA FEL (PL) NALOZIC (SLO) VSTAVITI (HR) PREKRITI

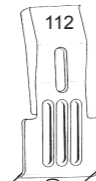
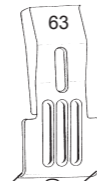
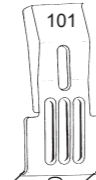
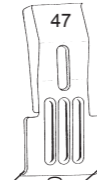
(IT) MODELLI AUTO (GB) CARS (E) COCHES (D) WAGEN (F) VOITURES (NL) AUTO (P) MODELO AUTO (H) AUTÓ TIPUS (PL) MODELE SAMOCHODÓW (SLO) MODELI AVTOMOBILOV (HR) MODELI AUTA	(IT) ANTERIORE (GB) FRONT (E) DELANTERO (D) VORDERE (F) AVANT (NL) VOORSTE G. (P) À FRENTE (H) ELSŐ RÚD (PL) PRZOD (SLO) SPREDAJ (HR) PREDNJI	(IT) POSTERIORE (GB) REAR (E) TRASERO (D) HINTERE (F) ARRIERE (NL) ACHTERSTE G. (P) ATRÁS (H) HÁTSÓ RÚD (PL) TYL (SLO) ZADAJ (HR) STRAŽNJI	   	<b>5</b>
---	---	--	---	----------

(IT) MONTAGGIO GANASCINE  
(GB) HOW TO ASSEMBLE THE CLAMPS  
(E) COMO MONTAR LAS FIJACIONES  
(D) ZUSAMMENBAU DER SPANNBACKEN  
(F) MONTAGE PATTE  
(NL) MONTAGE VAN DE KLEMMEN  
(P) COMO FIXAR OS SUPORTES  
(H) RÖGZÍTŐ FÜLEK  
(PL) MONTAZ SZCZEK MOCUJACYCH  
(SLO) MONTAŽA NAPENJALNIKA  
(HR) MONTAŽA ČELJUSTI

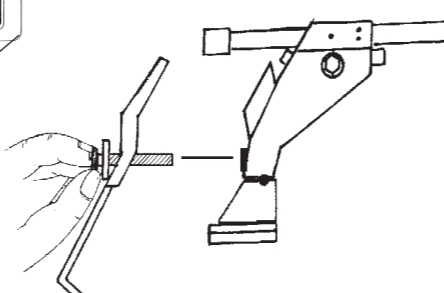
FORD Mondeo IV 4P (07>14)	101	101
FORD Mondeo IV 5P (07>14)	101	101
FORD Mondeo IV SW (07>14) No rails/Ohne reling	101	101
LEXUS IS II 4P (05>13)	63	63
NISSAN Micra IV 5P (10>17)	47	47
SEAT Ibiza IV 5P (08>17)	47	47
SKODA Fabia II 5P (07>15)	101	101
SKODA Superb II 4P (08>15)	63	63
SKODA Superb III 4P (15>)	47	47
TOYOTA Avensis Wagon SW (09>18)	47	47
VOLKSWAGEN Golf V 5P (03>09)	63	63
VOLKSWAGEN Golf V Plus MPV (05>06) No rails/Ohne reling	47	47
VOLKSWAGEN Golf V Plus MPV (07>09) No rails/Ohne reling	47	47
VOLKSWAGEN Golf VI 5P (08>12)	63	63
VOLKSWAGEN Jetta V 4P (05>10)	47	47
VOLKSWAGEN Passat VI 4P (05>10)	47	47
VOLKSWAGEN Passat VII 4P (10>14)	47	47
VOLKSWAGEN Polo IV 5P (01>09)	63	63
VOLKSWAGEN Polo V 5P (09>17)	112	63

**6**

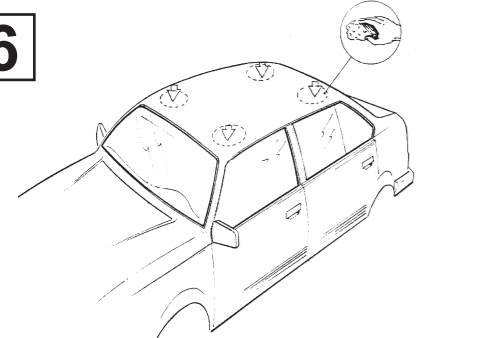

(IT) PULIRE IL TETTO  
(GB) CLEAN THE ROOF  
(E) LIMPIAR EL TECHO  
(D) DACH REINIGEN  
(F) NETTOYER LE TOIT  
(NL) DAK SCHOONMAKEN

(P) LIMPAR O TEJADILHO  
(H) TISZTÍTSA MEG A TETŐT  
(PL) WYCZYSCIC DACH  
(SLO) OČISTITI STREHO  
(HR) ČIŠEENJE KROVA

**7**

(IT) CENTRARE IL P. TUTTO SUL TETTO  
(GB) CENTRE THE UNIVERSAL BAR CARRIER ON THE ROOF  
(E) CENTRAR EL PORTAEQUIPAJES SOBRE EL TECHO  
(D) LASTENTRÄGER AUF DEM DACH ZENTRIEREN  
(F) CENTRER LE PORTE-TOUT SUR LE TOIT  
(NL) PLAATS DE UNIVERSELE DRAGER IN HET MIDDEN VAN HET DAK  
(P) CENTRAR AS BARRAS PORTA BAGAGENS NO TEJADILHO  
(H) HELYEZZE KÖZÉPRE A RUDAKAT  
(PL) WYSRODKOWAC BAGAZNIK NA DACHU  
(SLO) CENTRIRATI PRILJAŽNIK NA STREHO  
(HR) CENTRIRATI NOSAČE NA KROV

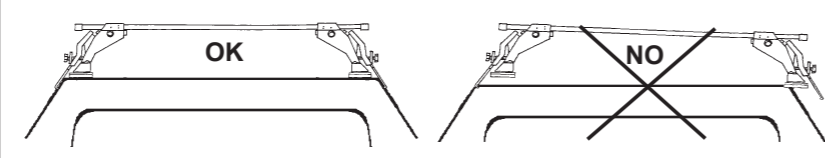

**8**



(IT) MODELLI CON PREDISPOSIZIONE DELLA CASA AUTO  
(GB) CARS WITH PRE-EXISTING FIXING POINT FROM MANUFACTURER  
(E) MODELOS CON PREDISPOSICION DEL FABRICANTE  
(D) AUTOS MIT VOM HERSTELLER VORGESEHENE BEFESTIGUNGSPUNKTE  
(F) VOITURES AVEC POINTS DE RÉPÈRE PREVUS PAR LE CONSTRUCTEUR  
(NL) AUTO'S MET DOOR DE FABRIKANT VOORZIENE MONTAGEPUNTEN  
(P) VIATURAS COM PONTOS DE FIXAÇÃO DO CONSTRUTOR PRÉ-EXISTENTES  
(H) FELHELYEZÉS GYÁRTÓ ÁLTAL KIJELÖLT PONTRA  
(PL) SAMOCHODY Z PRZEWDZIANYMI PUNKTAMI UMOCOWANIA  
(SLO) MODELI Z PREDVIDENIM LEŽIŠČEM S STRANI PROIZVAJALCA  
(HR) TVORNIČKI PRIPREMLJENI MODELI

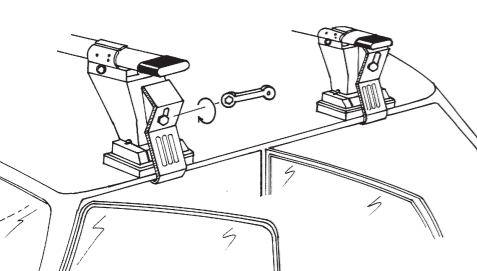



5 Nm

(IT) AVVITARE  
(GB) TO SCREW  
(E) APRETAR  
(D) FESTSCHRAUBEN  
(F) VISSER  
(NL) VASTSCHROEVEN  
(P) APERTAR  
(H) MEGHÚZNI  
(PL) WKRECIC  
(SLO) PRIVITI  
(HR) PRIČVRSTITI

(IT) MODELLI AUTO (GB) CARS (E) COCHES (D) WAGEN (F) VOITURES (NL) AUTO (P) MODELO AUTO (H) AUTÓ TIPUS (PL) MODELE SAMOCHODÓW (SLO) MODELI AVTOMOBILOV (HR) MODELI AUTA	(IT) ANTERIORE (GB) FRONT (E) DELANTERO (D) VORDERE (F) AVANT	(NL) VOORSTE G. (P) À FRENTE (H) ELSŐ RÚD (PL) PRZOD (SLO) SPREDAJ (HR) PREDNJI	(IT) POSTERIORE (GB) REAR (E) TRASERO (D) HINTERE (F) ARRIERE	(NL) ACHTERSTE G. (P) ATRÁS (H) HÁTSÓ RÚD (PL) TYL (SLO) ZADAJ (HR) STRAŽNJI
VOLKSWAGEN Golf V Plus MPV (07->09) No rails	T = 250 mm			Z

**9**

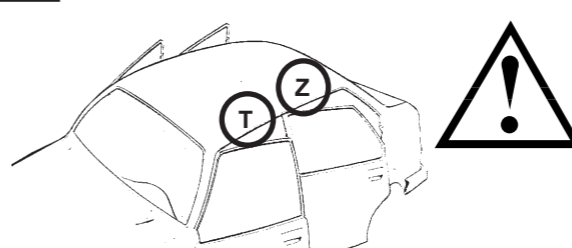
“À TROUVER SUR LE BATTANT DE LA PORTE OU DANS LE MANUAL TECHNIQUE DE LA VOITURE “

(IT) MODELLI CON PREDISPOSIZIONE DELLA CASA AUTO  
(GB) CARS WITH PRE-EXISTING FIXING POINT FROM MANUFACTURER  
(E) MODELOS CON PREDISPOSICION DEL FABRICANTE  
(D) AUTOS MIT VOM HERSTELLER VORGESEHENE BEFESTIGUNGSPUNKTE  
(F) VOITURES AVEC POINTS DE RÉPÈRE PREVUS PAR LE CONSTRUCTEUR  
(NL) AUTO'S MET DOOR DE FABRIKANT VOORZIENE MONTAGEPUNTEN  
(P) VIATURAS COM PONTOS DE FIXAÇÃO DO CONSTRUTOR PRÉ-EXISTENTES  
(H) FELHELYEZÉS GYÁRTÓ ÁLTAL KIJELÖLT PONTRA  
(PL) SAMOCHODY Z PRZEWDZIANYMI PUNKTAMI UMOCOWANIA  
(SLO) MODELI Z PREDVIDENIM LEŽIŠČEM S STRANI PROIZVAJALCA  
(HR) TVORNIČKI PRIPREMLJENI MODELI

(IT) MODELLI AUTO (GB) CARS (E) COCHES (D) WAGEN (F) VOITURES (NL) AUTO (P) MODELO AUTO (H) AUTÓ TIPUS (PL) MODELE SAMOCHODÓW (SLO) MODELI AVTOMOBILOV (HR) MODELI AUTA	(IT) ANTERIORE (GB) FRONT (E) DELANTERO (D) VORDERE (F) AVANT	(NL) VOORSTE G. (P) À FRENTE (H) ELSŐ RÚD (PL) PRZOD (SLO) SPREDAJ (HR) PREDNJI	(IT) POSTERIORE (GB) REAR (E) TRASERO (D) HINTERE (F) ARRIERE	(NL) ACHTERSTE G. (P) ATRÁS (H) HÁTSÓ RÚD (PL) TYL (SLO) ZADAJ (HR) STRAŽNJI
FORD Mondeo IV 4P (07->14)		T		Z
FORD Mondeo IV 5P (07->14)		T		Z
FORD Mondeo IV SW (07->14) No rails/Ohne reling		T		Z
SKODA Fabia II 5P (07->15)		T		Z
SKODA Superb II 4P (08->15)		T		Z
SKODA Superb III 4P (15->)		T		Z
VOLKSWAGEN Passat VI 4P (05->10)		T		Z
VOLKSWAGEN Passat VII 4P (10->14)		T		Z
VOLKSWAGEN Polo IV 5P (01->09)		T		Z

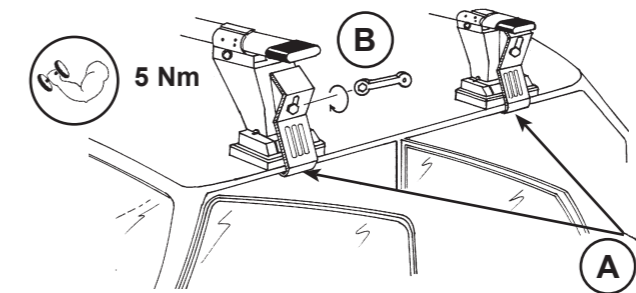

5 Nm

(IT) AVVITARE  
(GB) TO SCREW  
(E) APRETAR  
(D) FESTSCHRAUBEN  
(F) VISSER  
(NL) VASTSCHROEVEN  
(P) APERTAR  
(H) MEGHÚZNI  
(PL) WKRECIC  
(SLO) PRIVITI  
(HR) PRIČVRSTITI

**10**

“À TROUVER SUR LE BATTANT DE LA PORTE OU DANS LE MANUAL TECHNIQUE DE LA VOITURE “

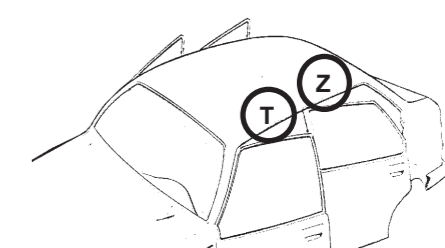

(IT) MODELLI CON PREDISPOSIZIONE DELLA CASA AUTO  
(GB) CARS WITH PRE-EXISTING FIXING POINT FROM MANUFACTURER  
(E) MODELOS CON PREDISPOSICION DEL FABRICANTE  
(D) AUTOS MIT VOM HERSTELLER VORGESEHENE BEFESTIGUNGSPUNKTE  
(F) VOITURES AVEC POINTS DE RÉPÈRE PREVUS PAR LE CONSTRUCTEUR  
(NL) AUTO'S MET DOOR DE FABRIKANT VOORZIENE MONTAGEPUNTEN  
(P) VIATURAS COM PONTOS DE FIXAÇÃO DO CONSTRUTOR PRÉ-EXISTENTES  
(H) FELHELYEZÉS GYÁRTÓ ÁLTAL KIJELÖLT PONTRA  
(PL) SAMOCHODY Z PRZEWDZIANYMI PUNKTAMI UMOCOWANIA  
(SLO) MODELI Z PREDVIDENIM LEŽIŠČEM S STRANI PROIZVAJALCA  
(HR) TVORNIČKI PRIPREMLJENI MODELI

(IT) MODELLI AUTO (GB) CARS (E) COCHES (D) WAGEN (F) VOITURES (NL) AUTO (P) MODELO AUTO (H) AUTÓ TIPUS (PL) MODELE SAMOCHODÓW (SLO) MODELI AVTOMOBILOV (HR) MODELI AUTA	(IT) ANTERIORE (GB) FRONT (E) DELANTERO (D) VORDERE (F) AVANT	(NL) VOORSTE G. (P) À FRENTE (H) ELSŐ RÚD (PL) PRZOD (SLO) SPREDAJ (HR) PREDNJI	(IT) POSTERIORE (GB) REAR (E) TRASERO (D) HINTERE (F) ARRIERE	(NL) ACHTERSTE G. (P) ATRÁS (H) HÁTSÓ RÚD (PL) TYL (SLO) ZADAJ (HR) STRAŽNJI
LEXUS IS II 4P (05->13)		T		Z

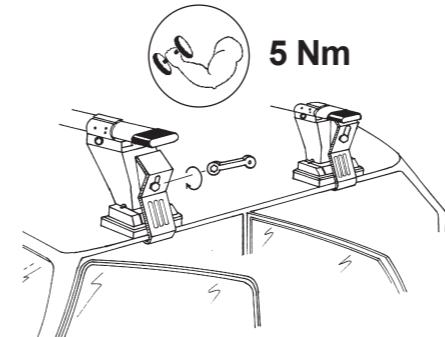

5 Nm

(IT) AVVITARE  
(GB) TO SCREW  
(E) APRETAR  
(D) FESTSCHRAUBEN  
(F) VISSER  
(NL) VASTSCHROEVEN  
(P) APERTAR  
(H) MEGHÚZNI  
(PL) WKRECIC  
(SLO) PRIVITI  
(HR) PRIČVRSTITI



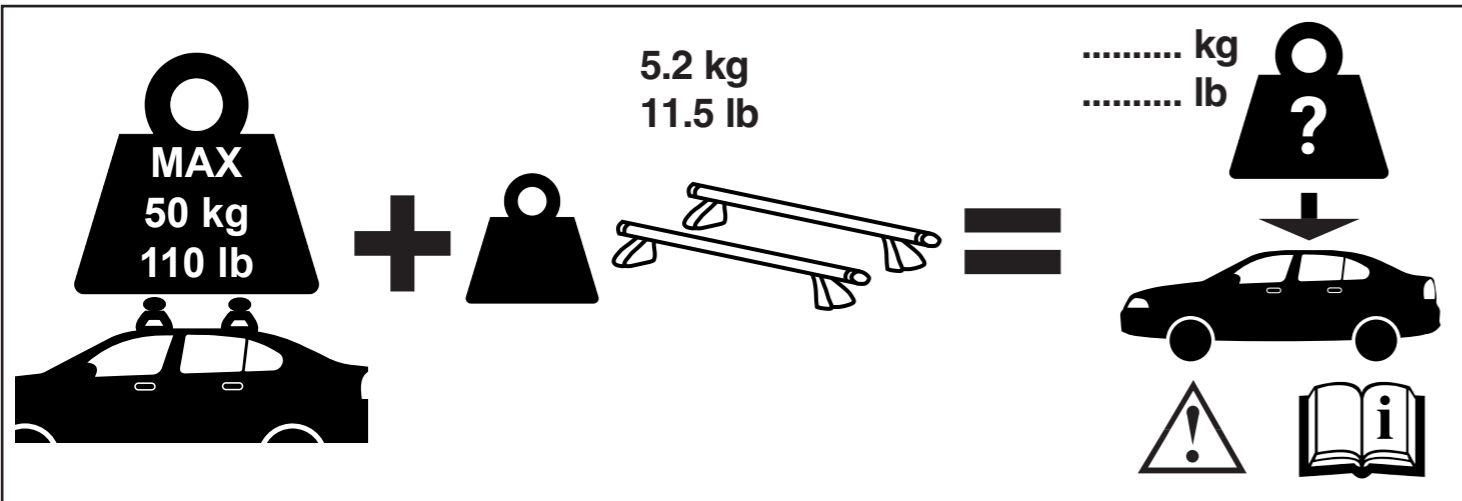

**COVER** (IT) ISTRUZIONI DI MONTAGGIO (GB) FITTING INSTRUCTIONS (F) INSTRUCTIONS DE MONTAGE (D) MONTAGEANWEISUNGEN (E) INSTRUCCIONES PARA SU MONTAJE (P) INSTRUÇÕES DE MONTAGEM (NL) MONTAGE INSTRUCTIES (H) SZERELÉSI UTASÍTÁS (PL) INSTRUKCJA MONTAZU (SLO) NAVODILA ZA MONTAŽO (HR) UPUTSTVO ZA MONTAŽU

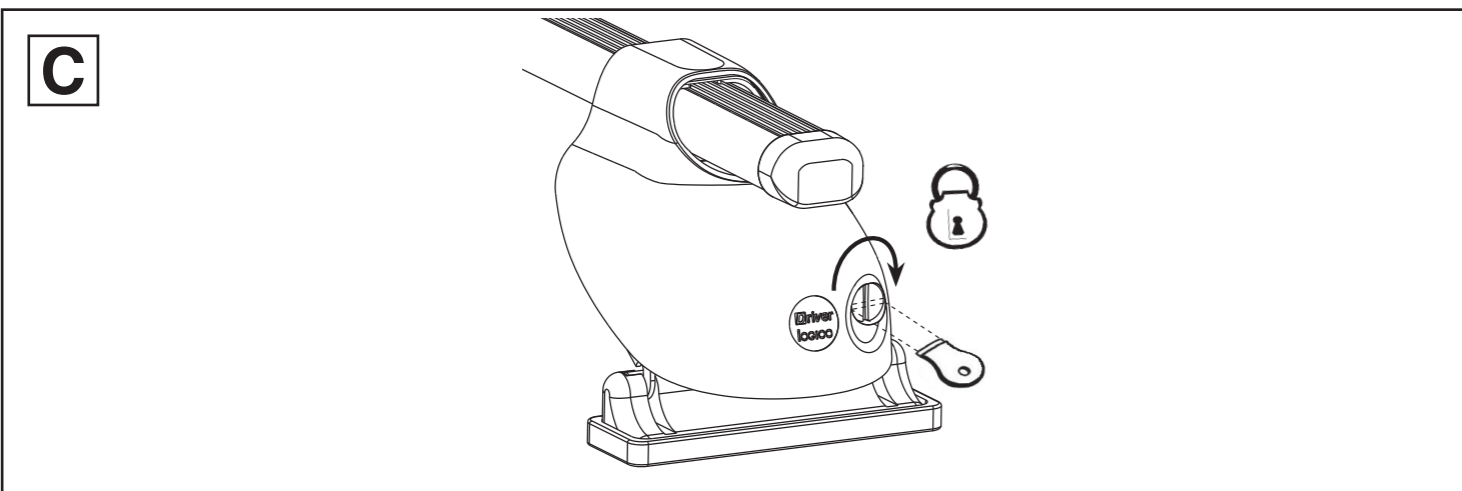
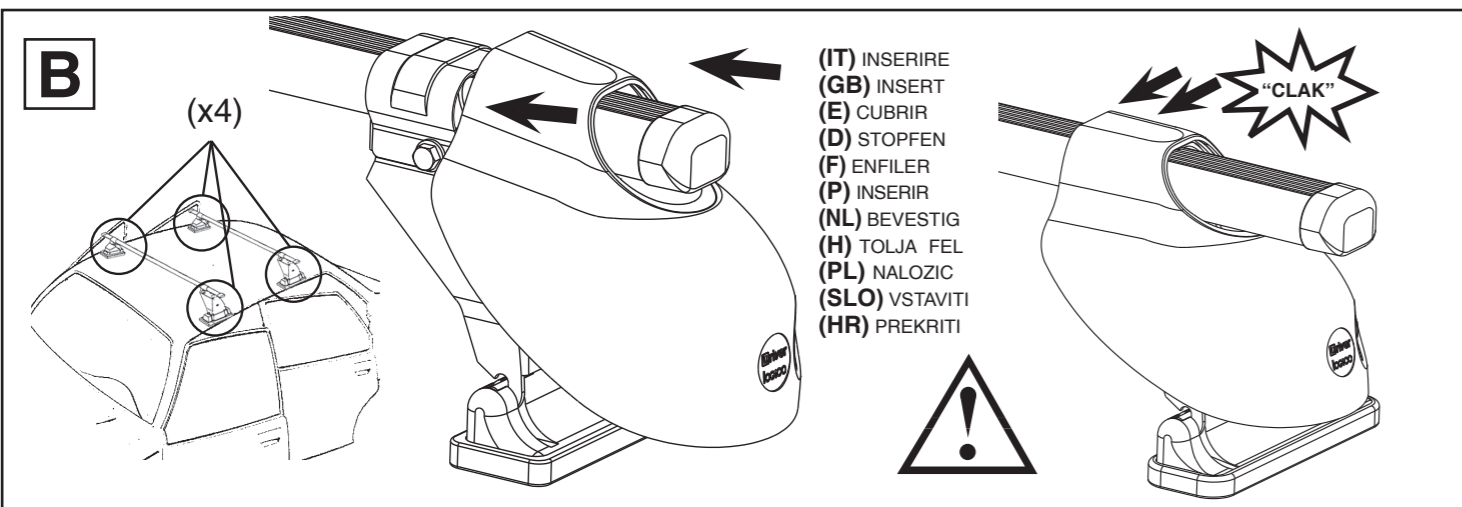
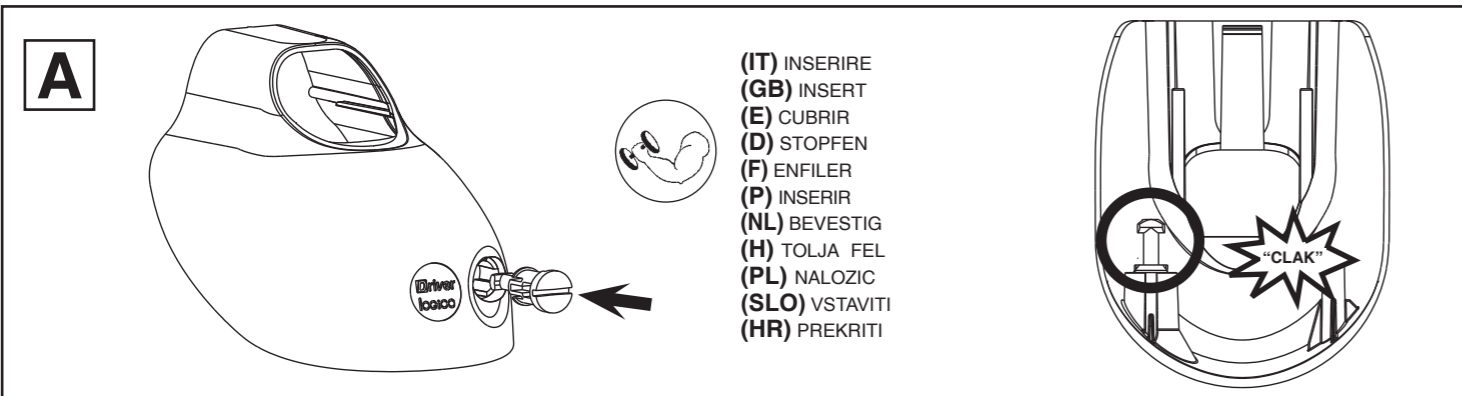

7

(IT) ISTRUZIONI DI MONTAGGIO (GB) FITTING INSTRUCTIONS (E) INSTRUCCIONES PARA SU MONTAJE (D) MONTAGEANWEISUNGEN (F) INSTRUCTIONS DE MONTAGE (NL) MONTAGE INSTRUCTIES (P) INSTRUÇÕES DE MONTAGEM (H) SZERELÉSI UTASÍTÁS (PL) INSTRUKCJA MONTAZU (SLO) NAVODILA O MONTAŽI (HR) UPUTE ZA MONTAŽU.

13

!

(IT) MODELLI AUTO  
(GB) CARS  
(E) COCHES  
(D) WAGEN  
(F) VOITURES  
(NL) AUTO  
(P) MODELO AUTO  
(H) AUTÓ TIPUS  
(PL) MODELE SAMOCHODÓW  
(SLO) MODELI AVTOMOBILOV  
(HR) MODELI AUTA

(IT) ANTERIORE  
(GB) FRONT  
(E) DELANTERO  
(D) VORDERE  
(F) AVANT  
(NL) VOORSTE G.  
(P) À FRENTE  
(H) ELSŐ RÚD  
(PL) PRZOD  
(SLO) SPREDAJ  
(HR) PREDNJI

VOLKSWAGEN Polo V 5P (09->17)

T = 250 mm

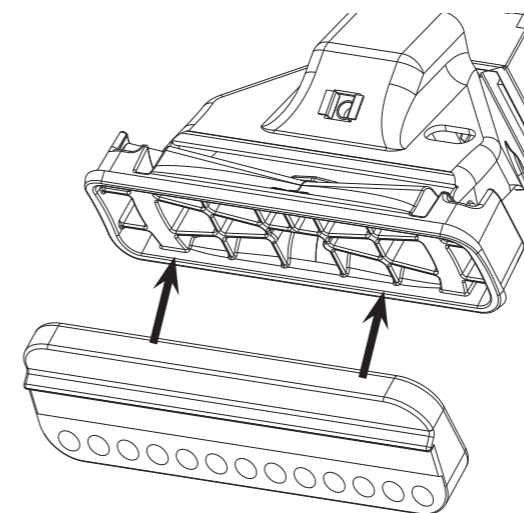

(IT) TOGLIERE  
(GB) REMOVE  
(E) ELIMINAR  
(D) ENTFERNEN  
(F) ENLEVER  
(P) REMOVER  
(NL) VERWIJDEREN  
(H) ELTÁVOLÍT  
(PL) USUNĄĆ  
(SLO) ODSTRANITI  
(HR) UKLONITI

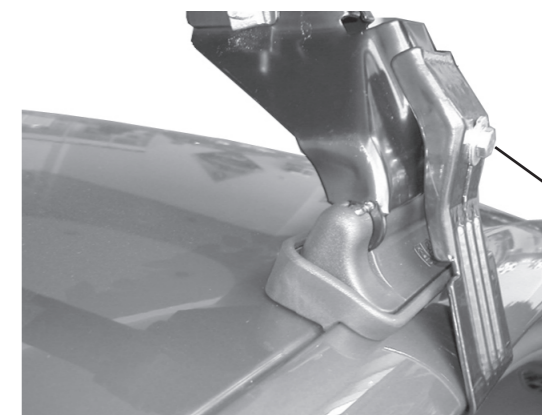
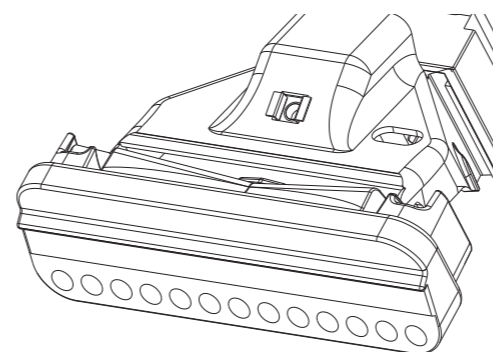
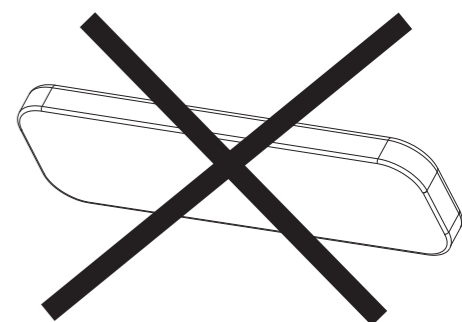
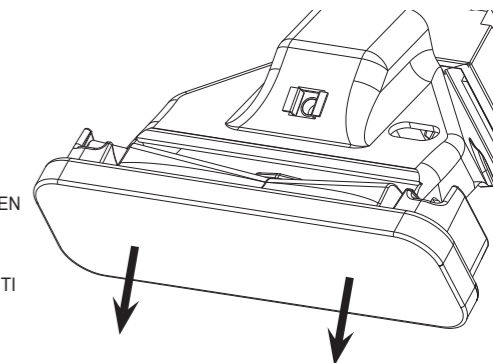

(IT) AVVITARE  
(GB) TO SCREW  
(E) APRETAR  
(D) FESTSCHRAUBEN  
(F) VISSER  
(NL) VASTSCHROEVEN  
(P) APERTAR  
(H) MEGHÚZNI  
(PL) WKRECIĆ  
(SLO) PRIVITI  
(HR) PRIČVRSTITI

(IT) MODELLI AUTO  
(GB) CARS  
(E) COCHES  
(D) WAGEN  
(F) VOITURES  
(NL) AUTO  
(P) MODELO AUTO  
(H) AUTÓ TIPUS  
(PL) MODELE SAMOCHODÓW  
(SLO) MODELI AVTOMOBILOV  
(HR) MODELI AUTA

(IT) POSTERIORE  
(GB) REAR  
(E) TRASERO  
(D) HINTERE  
(F) ARRIERE  
(NL) ACHTERSTE G.  
(P) ATRÁS  
(H) HÁTSÓ RÚD  
(PL) TYŁ  
(SLO) ZADAJ  
(HR) STRAŽNJI

VOLKSWAGEN Polo V 5P (09->17)

Z

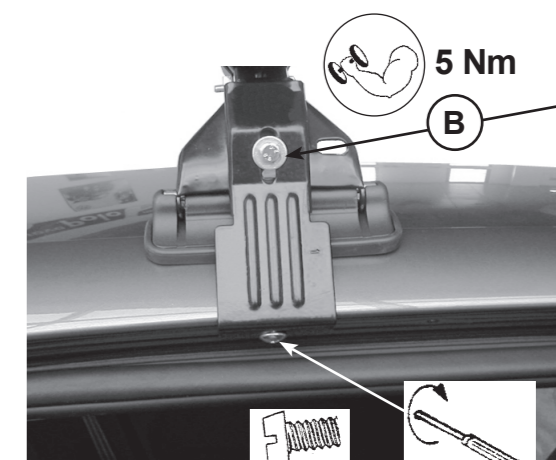

(IT) AVVITARE  
(GB) TO SCREW  
(E) APRETAR  
(D) FESTSCHRAUBEN  
(F) VISSER  
(NL) VASTSCHROEVEN  
(P) APERTAR  
(H) MEGHÚZNI  
(PL) WKRECIĆ  
(SLO) PRIVITI  
(HR) PRIČVRSTITI

6 X 14

A

24007

7

ISTRUZIONI DI MONTAGGIO / FITTING INSTRUCTIONS / INSTRUCCIONES PARA SU MONTAJE /  
MONTAGEANWEISUNGEN / INSTRUCTIONS DE MONTAGE / MONTAGE INSTRUCTIES /  
SZERELÉSI UTASÍTÁS / INSTRUKCJA MONTAŻU / NAVODILA O MONTAŽI.

# VW GOLF V 5P (2003->2009) VW POLO IV 5P (2001->2009)

DA APPLICARE IN CORRISPONDENZA DELLA ZONA DI APPOGGIO DELLA GANASCINA  
TO BE APPLIED IN CORRESPONDENCE OF THE FIXING AREA



ANTERIORE  
FRONT  
DELANTERO  
VORDERE  
AVANT  
VOORSTE G.  
EL ÖRE  
SPREDAJ

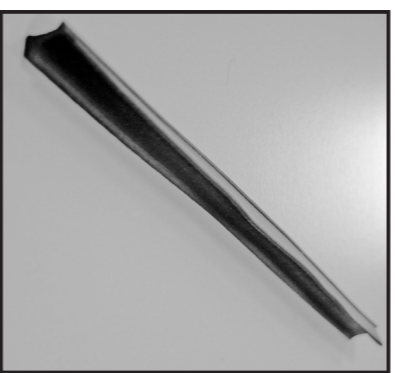
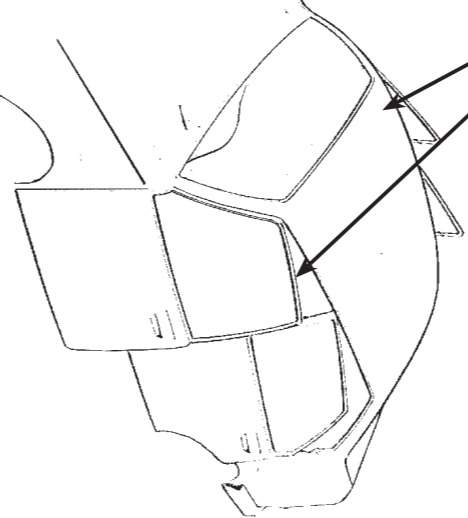

POSTERIORE  
REAR  
TRASERO  
HINTERE  
ARRIERE  
ACHTERSTE G.  
HÁTRA  
ZADAJ

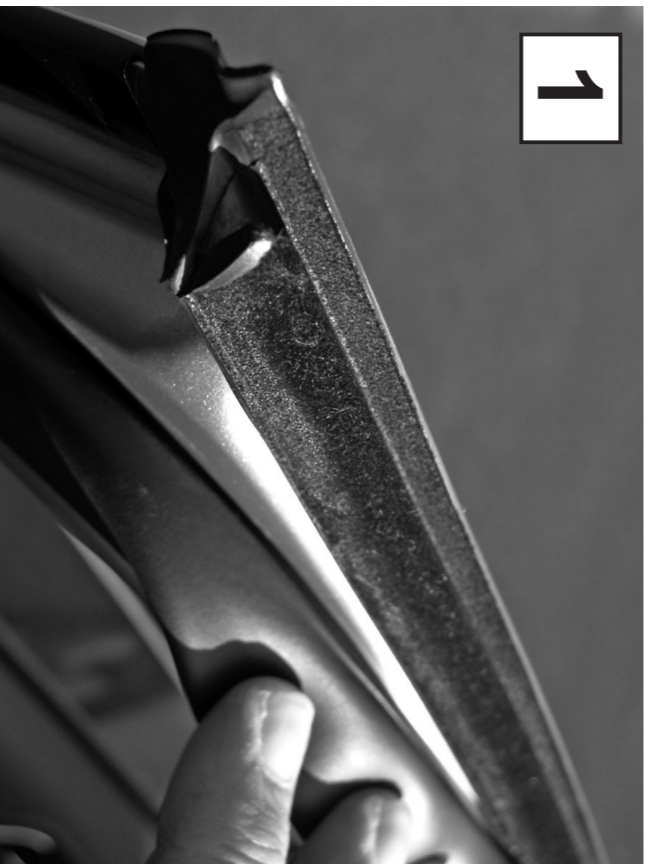
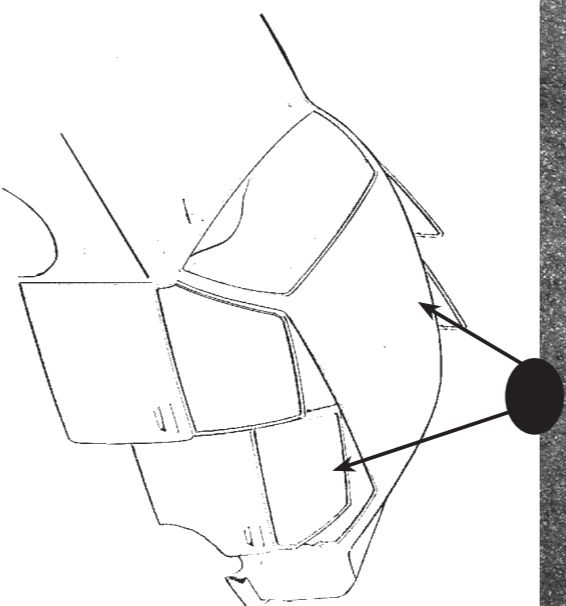

1



2



3



4