

URBAN BONFIRE[®]

REEF



This outdoor kitchen was designed to be both practical and efficient. Allowing you to effectively store seasonal or everyday items such as pots, gardening materials, outdoor cushions, towels and more, while leaving the counter clear for gardening or entertaining.

Details

Length 90" (includes countertop)

Height 36 1/2" (± 1")

Depth 28 3/4"

Kitchen Weight 204 lbs

Countertop Weight 243 lbs

Features

- Drawer (1)
- Refuse & Recycling Module (1)
- Shelf (1)
- Sink & Faucet
- Back Panels (optional)
- Dekton[®] Countertop (optional)

FRONT VIEW

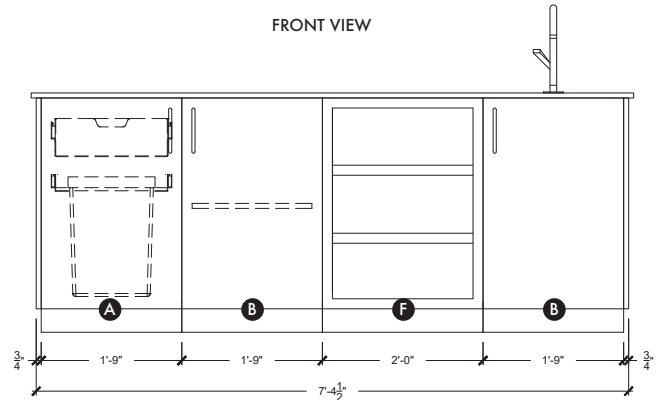

COUNTERTOP TEMPLATE

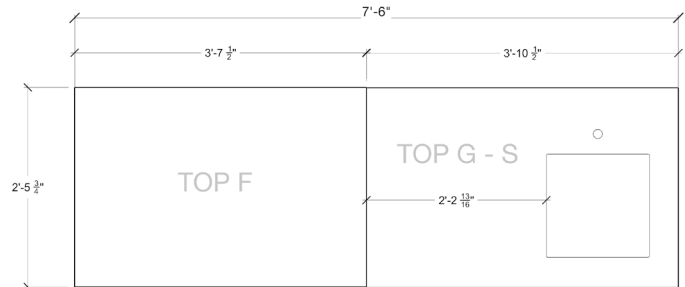

TOP VIEW (Gas & Electrical Conduits Access Points)

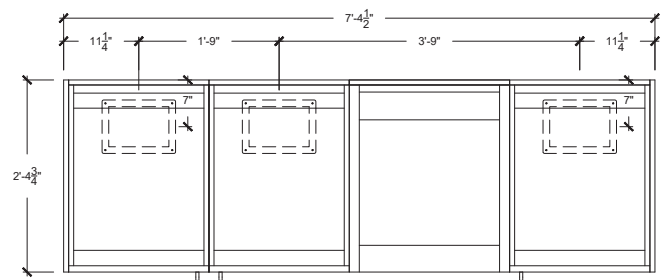

FRONT VIEW (Gas & Electrical Conduits Access Points)

