

EMAIL SUPPORT: SUPPORT@BUILTRIGHTIND.COM | PHONE SUPPORT: 203-546-8981 (9-5ET)

45 minutes
Normal install time

Watch for these icons:

IMPORTANT!
Important installation information

Tips and Tricks
To assist with installation

PARTS INCLUDED

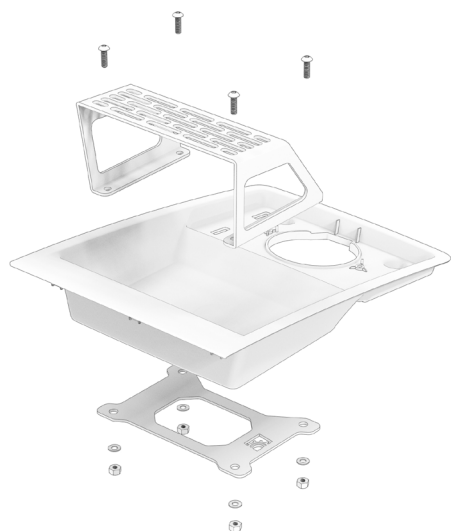

Dash Mount Kit Includes:

- 1x Dash Mount Bracket
- 1x Dash Mount Support Bracket (PRO Kit only)
- 4x M5 Stainless Steel Screw
- 4x M5 Stainless Steel Washer
- 4x M5 Stainless Steel Locking Nut

*OEM Tray pictured for assembly reference but not included

TOOLS REQUIRED

- Plastic trim tool (optional)
- Painter's tape (optional)
- 1/4in Drill Bit
- 1/8in Drill Bit
- 1/8in Allen Wrench
- 3/8in Socket or wrench
- 7mm Socket and Ratchet

PROCEDURE PART A: REMOVE DASH TRAY

The first step is to remove the dash tray from your truck. This is relatively simple and requires the removal of just two screws. A plastic trim tool will help, but is not necessary. Take your time and be patient to minimize the chance of broken clips. Use painter's tape to protect your dash if prying on it.

1. Begin by removing the cover from the speaker at the rear of the tray, if your truck is equipped with a center speaker. The cover is held down with four (4) spring-loaded clips. You can remove it by prying at one corner and then working on each of the others. Pull straight up - a rocking motion will help. If you pry against the other dash surfaces, you may use masking tape or a cloth of some sort to avoid marring.
2. Once the cover is removed, you'll have access to two (2) screws towards the rear of the tray. Use a socket to loosen and remove these and set them aside.
3. Now, pry up the front of the tray. The front is held in place with three (3) of the same spring-loaded clips and the same tips apply. Again, use tape to prevent marring to other panels if necessary.
4. Before removing the tray entirely, disconnect the speaker harness if equipped.

PROCEDURE PART B: INSTALL THE DASH MOUNT

The next step is to install the BuiltRight Industries Dash Mount onto your dash tray. Remove the rubber liner from the tray and set aside. After installation, you can either store this someplace safe, or trim it to fit back into the tray with the Dash mount.

1. Begin by setting the Dash Mount into the tray to determine where exactly you want to mount it. You have some flexibility here and will notice that the tray is angled toward the driver. Once you've selected a location, mark each of the mounting holes with a permanent marker (or other) and then set the Dash Mount aside.

CAUTION: If your truck is parked in freezing temperatures, allow the tray to reach room temperature before drilling. This will ensure that it isn't brittle and prone to cracking or chipping. Using drill bits of progressively larger size to reach the final 1/4in hole will help as well.

2. Start with a bit smaller than the 1/4in drill bit which will be the final hole size. This will help you place the mounting holes precisely. Drill each of two (2) easier to access holes first using the smaller bit and then with the 1/4in bit. Loosely bolt the mount to these holes and double check the location of the two holes closer to the driver.

3. The Dash Mount is made from 12ga steel, which provides excellent rigidity. With that said, we rely on the tray to provide lateral stability once mounted. For this reason, you are able to tweak the bracket slightly, should your holes not be perfect.

4. Use the provided M5 screws, washers and locking nuts to secure the Dash Mount to the tray as shown below. Install the Dash Mount Support bracket, if using the PRO Kit, between the tray and the washers.

PROCEDURE PART C: REINSTALL THE DASH TRAY

Finally, we're ready to reinstall the tray. **If you know what you'll be mounting to it, it may be easier to do that prior to putting the tray back into the truck.**

1. Position the dash tray back into the dash opening and reconnect the center speaker harness if applicable.

2. Set the dash tray into position and push down on the front, re-engaging the three (3) spring-loaded clips. You'll hear them click into place.

3. Reinstall the two (2) 7mm screws near the center speaker, if applicable, before replacing the center speaker cover.

Your installation is complete! The last step is to get it setup with the gear that you'll be mounting and share your installation photos with us via email (info@builtrightind.com) or on social media with #builtrightindustries. Thank you for your business and please don't hesitate to contact us directly with any questions. Illustrated guide and install video available at www.builtrightind.com/install and youtube if you're looking for additional information.