

QUICK INSTALLATION GUIDE

ECOSOL BOX TO LIBRA UL-R, ARES AND DEIMOS BT

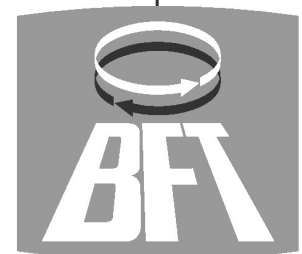

ECOSOL BOX



*Product to be installed by a qualified installer
Technical Support: 877-995-8155*

5 SIMPLE RULES TO FOLLOW WHEN INSTALLING AN ECOSOL

1. Keep the system as simple as possible. The simpler the system, the least energy it consumes, hence, the better performance.
2. **DO NOT PROGRAM REMOTES OR OPENING COMMAND INPUTS TO CONTROLLER BOARD.** All remotes and open command inputs must be wired to the ECOSOL board.
3. Free exit devices and magnetic loop detectors draw current at all times so it is suggested not to implement them. If a free exit device is a must, low power consumption detectors such as the Diablo Controls model DSP-6LP and DSP-7LP are strongly recommended over photocell sensors.
4. As a general rule, the solar panel should always face south and at an angle equal to the locations latitude +/- 10°, in a shade free area.
5. When in doubt, call tech support. **877-995-8155** or 561-995-8155

ECOSOL HARNESS ASSEMBLY

<p>Strip a 4 conductor cable according to drawing</p> <p>1</p> <p>5 mm 21 mm</p>		<p>Strip a 4 conductor cable according to drawing</p> <p>1</p> <p>4 mm 10 mm</p>	
<p>2</p> <p>12 mm / 4 x 2.5 mm²</p> <p>Run the cable through the connector</p>		<p>2</p> <p>Run the cable through the connector components</p>	
<p>3</p> <p>Connect wires to respective terminals</p>		<p>3</p> <p>Connect wires to respective terminals</p>	
<p>4</p> <p>Secure terminal to connector</p>		<p>4</p> <p>Secure terminal to connector</p>	
<p>5</p> <p>Tighten connector to cable</p>		<p>5</p> <p>Tighten connector to cable</p>	
<p>6</p> <p>Connect the assembly to its corresponding receptacle on the right side of the ecosol box</p>		<p>6</p> <p>Connect the assembly to its corresponding receptacle on the right side of the ecosol box</p>	

ECOSOL CONNECTIONS TO THE DEIMOS BT & ARES

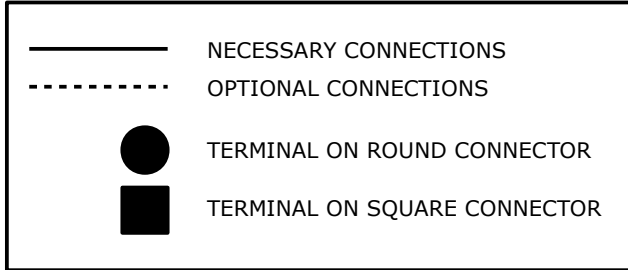

Transformer wires must be disconnected

DEIMOS BT / ARES TERMINAL STRIP

3	-24 V IN
4	+24 V IN
17	+ V-SAFE
21	COMMON
22	START
23	STOP
24	PHOTO (SAFETY)
25	BAR
26	OPEN

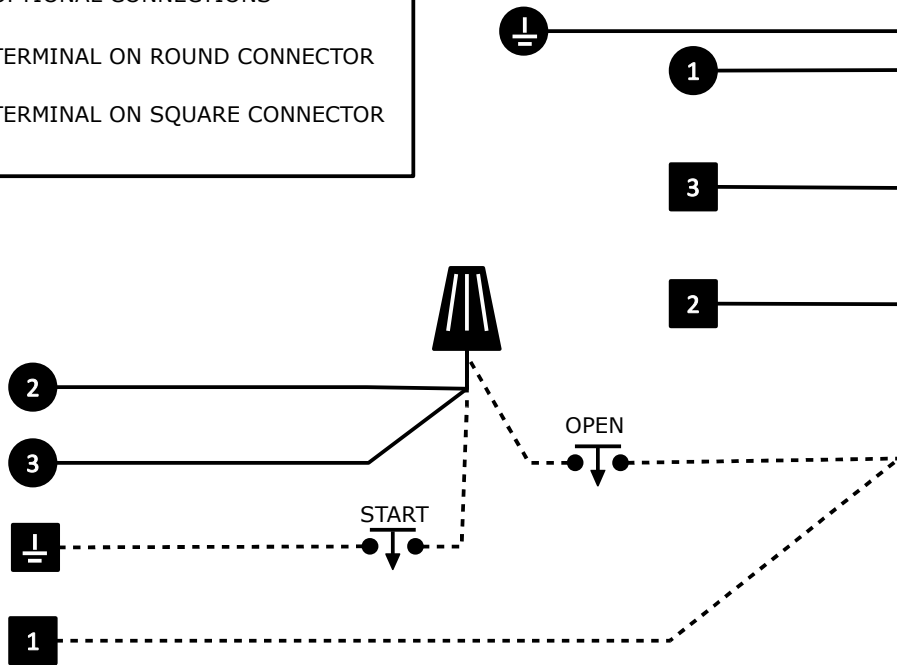

ECOSOL CONNECTIONS TO LIBRA UL-R

Transformer wires must be disconnected

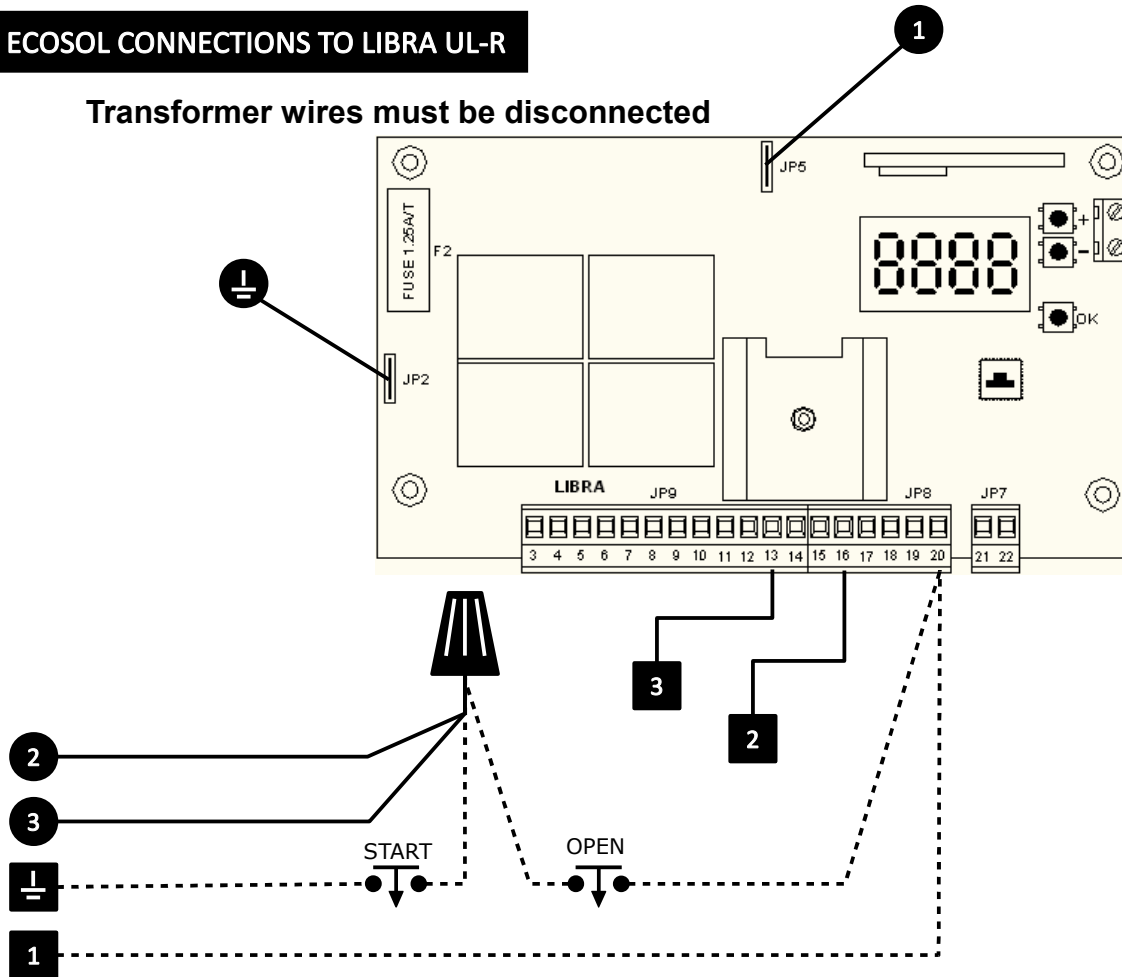

ECOSOL CONNECTIONS TO LIBRA UL-R

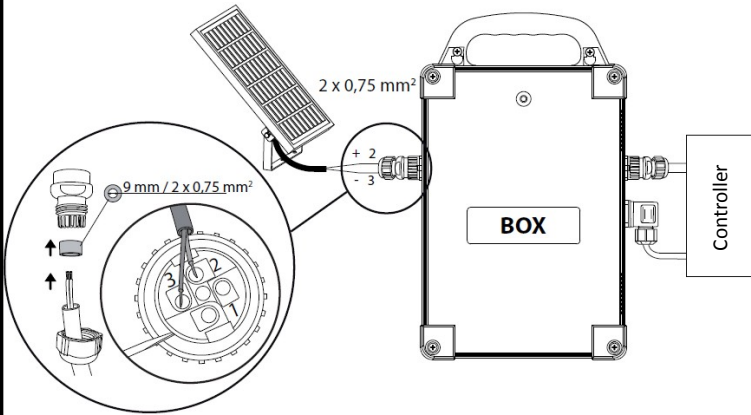

ALWAYS-ON ACCESSORY POWER

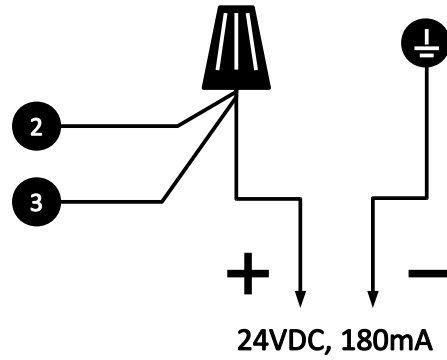

DIPSWITCH PROGRAMMING

DIPSWITCH 1

Turn on when ECOSOL Double (external battery pack) is connected to Ecosol board.

DIPSWITCH 2

Turn on for transmitter activated transmitter learning.

DIPSWITCH 3 & 4

Initial command delay setting
 All off: 1.3 seconds
 3 On: 1.5 seconds
 4 On: 1.7 seconds
 3 & 4 On: 2.1 seconds

PROGRAMMING
DIPSWITCHES

RADIO LEARN
BUTTON

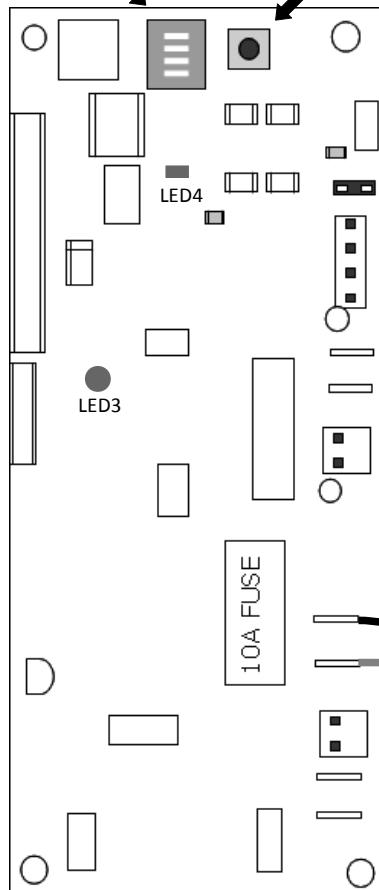

RADIO TRANSMITTER PROGRAMMING

1. Press RADIO LEARN BUTTON once. LED3 should blink once every second.
2. Press and hold the 2 top buttons on your transmitter until LED3 turns on solid.
3. Press the desired button on the transmitter. LED3 should blink rapidly for a second then go back to a blink per second.
4. If additional transmitter needs to be learned, repeat steps 2 and 3 while LED3 is blinking.

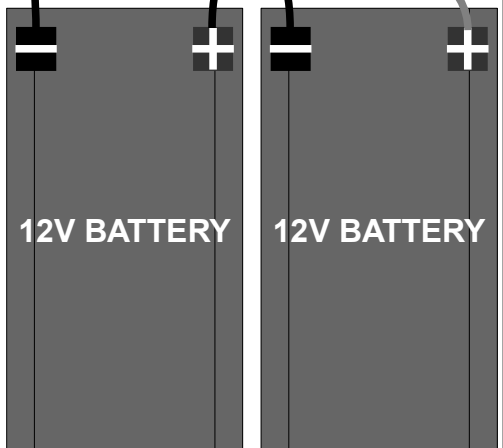

*Product to be installed by a qualified installer
 Technical Support: 877-995-8155*