

GRIDDLES & BROILERS**VULCAN****VSP SERIES
STOCKPOT RANGES**

Model VSP100

- VSP100** One section, 18" wide x 24.5" deep
 VSP200F Two sections, 18" wide x 49" deep

STANDARD FEATURES

- Stainless steel front and sides.
- Heavy cast iron top grate(s).
- Two concentric 55,000 BTU/hr. ring-type burners per 18" section; 110,000 BTU/hr. input per section.
- Standing pilot ignition system.
- Two infinite heat control valves per section.
- Heat shield to protect control valves.
- 3/4" rear gas connection and gas pressure regulator.
- One year limited parts and labor warranty.

**SPECIFICATIONS****Exterior Dimensions:**

18" wide x _____" deep x 22½" to 24" working height on adjustable legs

CSA design certified. NSF listed.

SPECIFY TYPE OF GAS WHEN ORDERING.**SPECIFY ALTITUDE WHEN ABOVE 2,999 FT.**

NOTE: Models are constructed standard for natural gas service. Propane conversion kit is supplied with the unit. Conversion is the customer's responsibility. Please indicate propane or natural gas when processing your order.

NOTE: Elevation orifice kit is available free of charge for high-elevation applications. Installation is the customer's responsibility. Please indicate elevation when processing your order.

VULCAN

a division of ITW Food Equipment Group LLC

P.O. Box 696 ■ Louisville, KY 40201 ■ Toll-free: 1-800-814-2028 ■ Local: 502-778-2791 ■ Quote & Order Fax: 1-800-444-0602



VSP SERIES
STOCKPOT RANGES

INSTALLATION REQUIREMENTS:

1. A gas pressure regulator sized for this unit was included.
Natural Gas 5" W.C.
Propane Gas 10" W.C.
2. Gas line connecting to appliance must be 3/4" diameter or larger.
If flexible connectors are used, the inside diameter must be the same as the 3/4" pipe.
3. An adequate ventilation system is required for commercial cooking equipment. Information may be obtained by writing to the National Fire Protection Association, 1 Batterymarch Park, Quincy, MA 02169, www.NFPA.org. When writing refer to NFPA No. 96.
4. These units are manufactured for installation in accordance with National Fuel Gas Code, ANSI-Z223.1/NFPA #54 (latest edition). Copies may be obtained from The American Gas Association,

Accredited Standards Committee Z223 @ 400N. Capital St. NW, Washington, DC 20001, or the Secretary Standards Council, NFPA, 1 Batterymarch Park, Quincy, MA 02169-7471.

NOTE: In the Commonwealth of Massachusetts

All gas appliances vented through a ventilation hood or exhaust system equipped with a damper or with a power means of exhaust shall comply with 248 CMR.

5. Clearances:

	Combustible	Non-Combustible
Rear	24"	4"
Sides	18"	0"
6. This appliance is manufactured for commercial installation only and is not intended for home use.

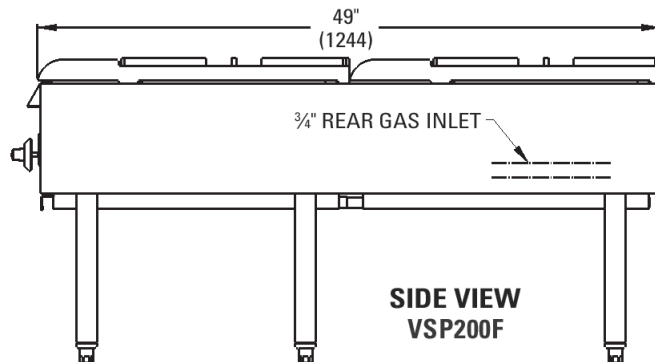
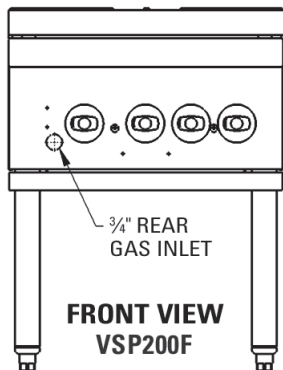
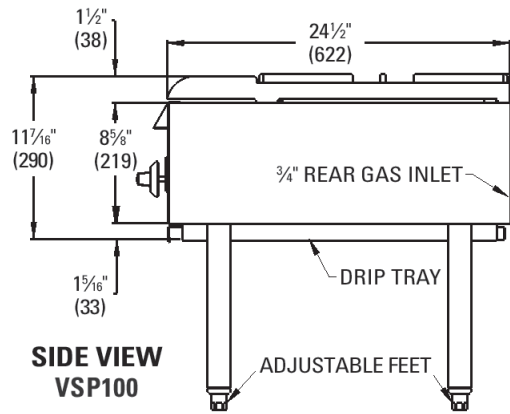
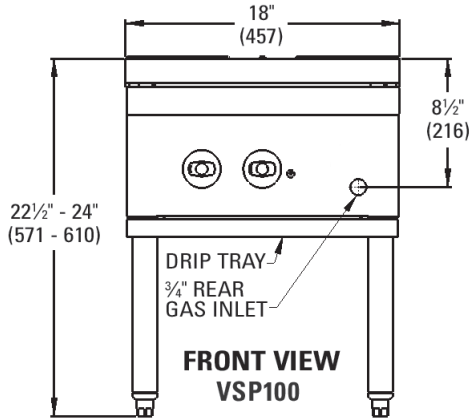

MODEL	TOTAL BTU/HR.	WIDTH	DEPTH	HEIGHT	APPROX. SHIP WT. (LB/KG)
VSP100	110,000	18"	24 1/2"	22 1/2" to 24"	145/66
VSP200F	220,000	18"	49"	22 1/2" to 24"	290/131



a division of ITW Food Equipment Group LLC

P.O. Box 696 ■ Louisville, KY 40201 ■ Toll-free: 1-800-814-2028 ■ Local: 502-778-2791 ■ Quote & Order Fax: 1-800-444-0602

NOTE: In line with its policy to continually improve its products, Vulcan reserves the right to change materials and specifications without notice.