

## FEATURES

- Stainless steel body & interior with aluminum back
- Stainless steel insulated door
- Fan forced cooling system
- Self-evaporation water tray
- Includes 1 heavy duty epoxy coated shelf
- Includes 4" heavy duty locking casters
- Self-closing swing doors with 90 degree stay open feature
- Digital temperature controller & defrost timer
- Heavy duty 1/5 HP Embraco compressor



UCF-27

## TEMPERATURE

- Interior temperature range: -18°C to -22°C (-0.4°F to -7.6°F)

## WARRANTY

- 2 years parts and labour  
7 years compressor warranty
- Extended warranty options available

Project: \_\_\_\_\_

Date: \_\_\_\_\_

Price: \_\_\_\_\_

Model UCF-27

Undercounter Freezer

## SPECIFICATIONS

Volts (V)	Watts (W)	Amps (A)	Volume (cu./ft)	Refrigerant	Overall Dimensions			Interior Dimensions			Weight	
					Width	Depth	Height	Width	Depth	Height	Net	Gross
115V	241W	2.1A	6.3	R290	27	29.5	35.5	N/A	N/A	N/A	210 LBS	N/A

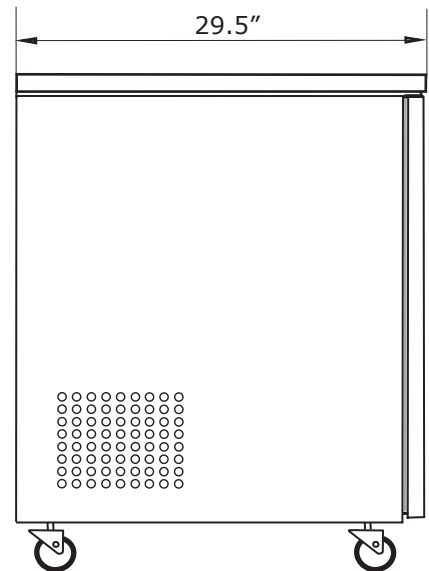
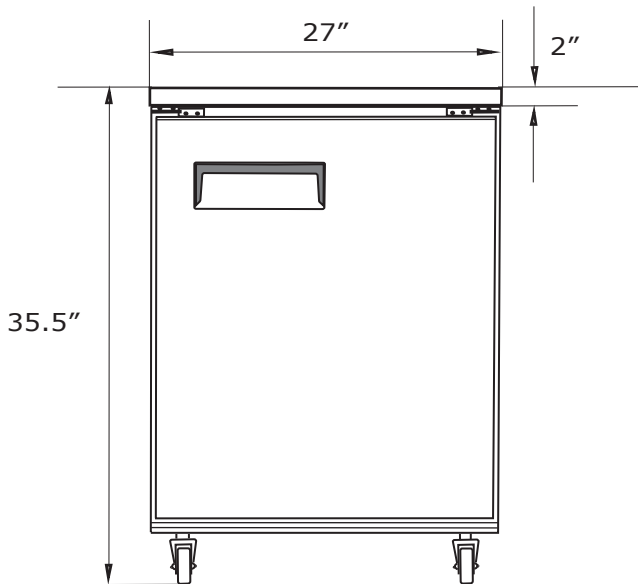

Undercounter Freezer

Model UCF-27

CERTIFICATIONS:



NEMA 5-15P

Local: 905-669-8003  
Toll Free: 1-833-669-8003

2884 Slough Street, Unit 1  
Mississauga, ON Canada