

30DSERIES

turbofan[®]

E33D5
(Digital Operation)
(2 Speed Fan)

Installation and Operation Manual

turbofan
CONVECTION OVEN SYSTEMS

MOFFAT[®]

BLUE SEAL[®]

MANUFACTURED BY

Moffat Limited

Christchurch
New Zealand

INTERNATIONAL CONTACTS

AUSTRALIA

Moffat Pty Limited

Web: www.moffat.com.au
E.Mail: vsales@moffat.com.au
Main Office: (tel) +61 (03) 9518 3888
(fax) +61 (03) 9518 3833
Service: (tel): 1800 622 216
Spares: (tel): 1800 337 963
Customer Service: (tel): 1800 335 315
(fax): 1800 350 281

CANADA

Serve Canada

Web: www.servecanada.com
E.Mail: info@servecanada.com
Sales: (tel): 800 551 8795 (Toll Free)
Service: (tel): 800 263 1455 (Toll Free)

NEW ZEALAND

Moffat Limited

Web: www.moffat.co.nz
E.Mail: sales@moffat.co.nz
Main Office: (tel): 0800 663328

UNITED KINGDOM

Blue Seal

Web: www.blue-seal.co.uk
E.Mail: sales@blue-seal.co.uk
Sales: (tel): +44 121 327 5575
(fax): +44 121 327 9711
Spares: (tel): +44 121 322 6640
(fax): +44 121 327 9201
Service: (tel): +44 121 322 6644
(fax): +44 121 327 6257

UNITED STATES

Moffat

Web: www.moffat.com
Sales: (tel): 800 551 8795 (Toll Free)
(tel): +1 336 661 1556
(fax): +1 336 661 9546
Service: (tel): 800 858 4477 (Toll Free)
(tel): +1 336 661 1556
(fax): +1 336 661 1660

REST OF WORLD

Moffat Limited

Web: www.moffat.co.nz
E.Mail: export@moffat.co.nz

The reproduction or copying of any part of this manual by any means whatsoever is strictly forbidden unless authorized previously in writing by the manufacturer.

In line with policy to continually develop and improve its products, Moffat Ltd. reserves the right to change the specifications and design without prior notice.

Contents List

E33 Turbofan Convection Oven.

Model Numbers Covered in this Manual

E33D5 - Turbofan Oven - 5 Tray Convection Oven.

Introduction	2
Safety Information	
Specifications	3
Installation	4
Installation Requirements	
Unpacking	
Location	
Clearances	
Stand Mounted Ovens	
Electrical Connection	
Water Connection	
Positioning and Levelling of Oven	
Initial Start-Up	
Commissioning	
Operation.....	6
Operation Guide	
Oven Control Panel	
Starting the Oven	
Oven Shut-Down	
Cooking in Manual Mode	
Cooking in Core Temp Mode	
Moisture Mode	
Core Probe Cooking	
Cooking in Program Mode	
Oven Programs - Programming	
Controller - User Settings.....	13
User Settings	
Cleaning and Maintenance	14
Cleaning Guidelines	
Oven Cleaning	
Periodic Maintenance	
Fault Finding.....	17
Electrical Schematics.....	18
Replacement Parts List.....	19

Introduction

Before using your new oven, please read this instruction manual carefully, pay particular attention to any information labelled '**WARNING**', '**CAUTION**', '**IMPORTANT**' or '**NOTE**' in this manual.

 **Warning** Indicates a hazardous situation which, if not avoided, will result in death or serious injury.

 **Caution** Indicates a hazardous situation which, if not avoided, will result in minor or moderate injury.

If you are unsure of any aspect of the installation, instructions or performance of your oven, contact your TURBOFAN dealer promptly. In many cases a phone call could answer your question.

Should you contact your TURBOFAN dealer on any matter concerning this oven, please have the information provided opposite, readily available.

This manual must be kept by the owner for future reference.

A record of **Date of Purchase**, **Date of Installation** and **Serial Number of the oven** should be recorded in the area provided below.

The serial number of this oven can be found on the Technical Data Plate located on the front right hand side panel, see diagram in 'Installation Section'.

Model Number:

Serial Number:

Dealer:

Service Provider:

Date Purchased:

Date Installed:

Safety Information

For your safety, please pay attention to the following symbols marked on the appliance.

- Risk of electric shock.



No user serviceable parts inside.

Qualified service person access only.

Disconnect from power before servicing.

Specifications

E33D5

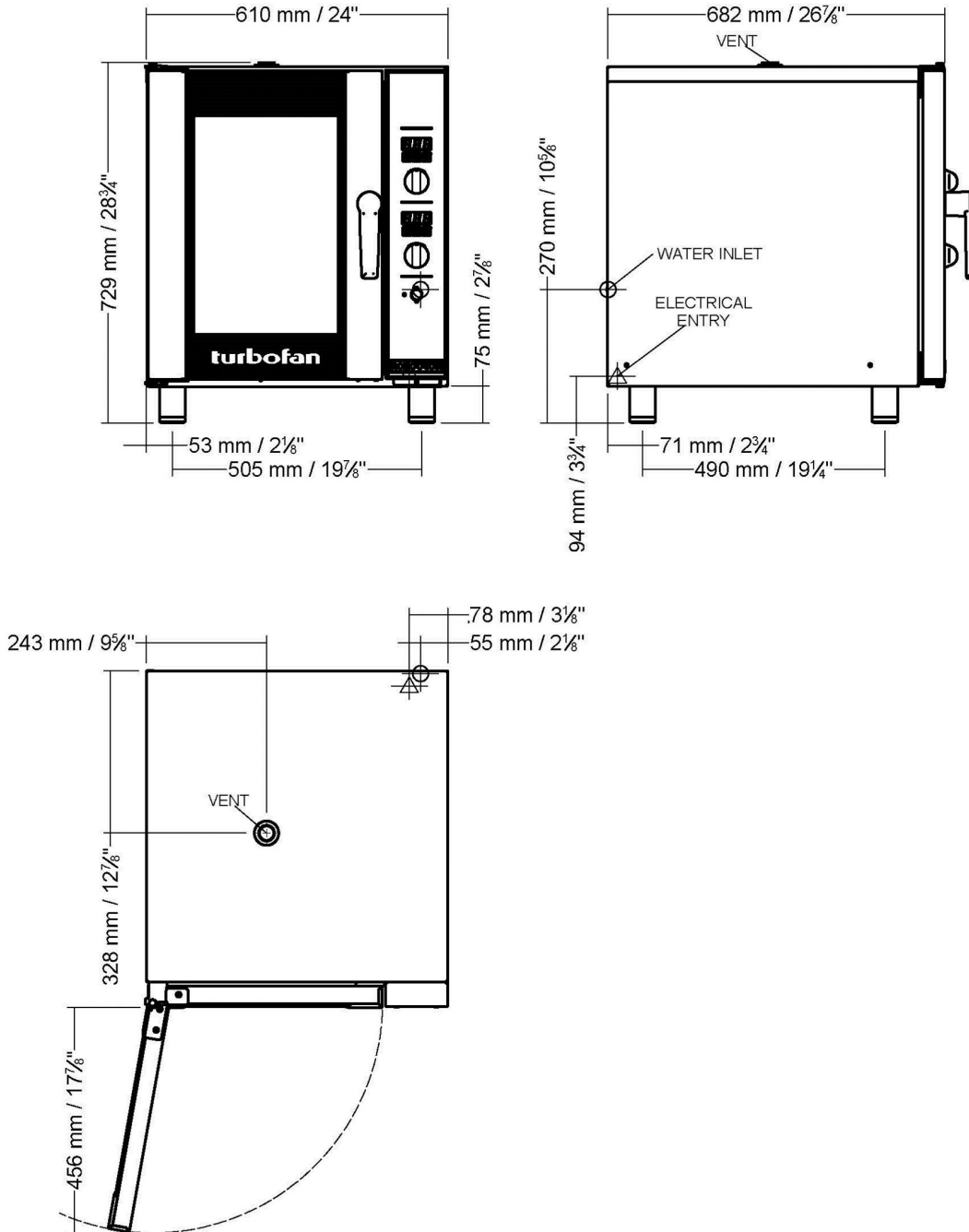

Oven Specifications.

Oven Power Ratings		USA / Canada	Other Markets
		208V, 60Hz, 5.4kW. 220 - 240V, 60Hz, 6.0kW.	220V, 50Hz or 60Hz, 6.0kW. 230 - 240V, 50Hz or 60Hz, 6.0kW.
Oven Tray Details	Tray Capacity	5 Shelf - 13" x 18" Bun Pan. 12" x 20" Steam Pan.	5 Shelf, 1/1 GN Pan.
	Tray Spacing	3 1/3" / 85mm.	85mm / 3 1/3".
Water Connection	Max Water Pressure	80psi / 550kPa.	80psi / 550kPa.
	Connection Size	3/4" GHT.	3/4" BSP.

Installation

Installation Requirements

Important:

- Installation shall comply with local electrical, health and safety requirements.
- It is most important that this oven is installed correctly and that oven operation is correct before use.
- If you have any questions regarding the proper installation and / or operation of this oven, please contact your local Turbofan distributor.

Unpacking

1. Remove all packaging and transit protection including all protective plastic coating from the exterior stainless steel panels.
2. Check the oven and supplied parts for damage. Report any damage immediately to the carrier and distributor.
3. Check that the following parts have been supplied with your oven:-
 - 4 x Leg Adjustable.
 - Adaptor Brass. } USA / Canada only.
 - Washer Rubber. }
4. Report any deficiencies to the distributor who supplied your oven.
5. Securely fit the 4 legs supplied with the oven.
6. Check that the available electrical supply is correct to that shown on the Technical Data Plate located on the front right hand side panel.

- Refer to 'Specifications' section, 'Oven Specifications Table' on previous page.

Location

1. Position the oven in its approximate working position.
2. The unit should be positioned so that the control panel and oven shelves are easily reachable for loading and unloading.



Technical Data Plate - Data and Location

Clearances

To ensure correct ventilation for the motor and controls, the following minimum installation clearances are to be adhered to:-

Top	200mm / 8".
Rear	50mm / 2".
Left-hand side	50mm / 2".
Right-hand side	75mm / 3".

NOTE: Fixed installations require at least 500mm - 20" clearance at the right hand side of oven for service access.

Important:

The vent located on the top of the oven must NOT be obstructed.



Stand Mounted Oven

For stand mounted ovens, the oven feet are used to level the oven on the stand. Refer to the instructions supplied with separately ordered stands for mounting details.

Installation

Electrical Connection



Warning

This oven must be earthed / grounded.

Each oven should be connected to an adequately protected power supply with an appropriate three wire power cord.

An isolation switch must be mounted adjacent to, but not behind the oven and must be readily accessible to the operator. This switch must be clearly marked and readily accessible in case of fire.

Check the electricity supply is correct to as shown on the Technical Data Plate on the front right hand corner of the oven side panel.

NOTE: All electrical connections must only be carried out by a suitably qualified person.

1. Remove oven right hand side panel.
2. Bring the supply cable up through the grommet at the back of oven and through the compression gland on the electrical switchgear panel.
3. Connect the mains supply to the appropriately marked terminals on the terminal block.

Water Connection

(Not required for Main Oven Operation)

1. If the manual addition of water into the oven for humidification or steaming effect on baked product is required, the unit's water connection can be used.
2. Tighten the 2 screws securing the water connection to the rear of the oven. (These have purposely been left loose to prevent damage to the water connection during transit).



3. A cold water supply should be fitted to the 3/4" BHP water inlet which is located on the rear, right hand side of the oven. (USA / Canada only, supplied with 3/4" GHT adaptor).
4. Connect to the water supply.

- Max Inlet Pressure 80psi / 550kPa.

5. Turn 'On' the water supply and check for leaks.

Positioning and Levelling of Oven

1. Correctly locate the oven into its final operating position and using a spirit level, adjust the oven feet so that the oven is level and at the correct height.

Initial Start-Up

Before using the new oven;

1. For first time use of the oven, operate the oven for about 1 hour at 200°C / 400°F to remove any fumes or odours which may be present.
2. Please refer to the Operation Section of this manual for details on how to correctly operate and shutdown the oven.

Commissioning

Before leaving the new installation;

Check the oven functions in accordance with the operating instructions specified in the 'Operation' section of this manual.

Ensure that the operator has been instructed in the areas of correct operation and shutdown procedure for the appliance.

NOTE: If it is not possible to get the appliance to operate correctly, turn 'Off' the power at the mains supply and contact the supplier of this appliance.

Operation

Operation Guide



Warning

Some parts of this oven will become **VERY HOT** during use and could cause burns if touched.



Warning

Take care when opening the oven door during baking. Let the hot air and steam escape before removing or replacing food as the steam produced can cause steam burns.

- Turbofan Ovens have been designed to provide simple operation.
- This oven is intended for use in a commercial kitchen and must only be put to the use for which it was intended, i.e. cooking food product. To use this oven correctly please read the following sections carefully:-

Oven Control Panel

185

Temperature Display -

Shows the pre-set chamber temperature.

When used with the 'Temperature' key, display shows actual oven temperature for 5 seconds. Shows Cooking Modes and Error Codes.



Steam Key and LED -

Activates the 'Steam Mode'.

Temperature Adjustment Control

125

Time Display -

Shows cook time in full minutes only from 180 - 1, and in seconds for the final minute only.

NOTE; In Core Temp Mode, the display shows 'CP' and Core Temperature of item being cooked.



On / Off / Key and LED

Press 'On / Off' key once to turn the oven 'On'.

Press and hold 'On / Off' key for 2 seconds to turn the oven 'Off'.

Time Adjustment Control.

NOTE; In Core Temp Mode, Timer Knob is used to set Core Probe Temperature.



Programming Key and LED -

Used to enter the 'Programming' mode.



Temperature Key and LED -

Shows actual oven temperature for 5 seconds on the Temperature Display,

LED 'On' when heating.

LED flashes when showing actual temperature.

NOTE; In Core Temp Mode, this key is used to display Actual Oven and Core Probe temperatures.



Fan Lo/High Speed Key and LED -

Switches oven fan from high to low speed. LED is 'On' when fan is in Low Speed mode.



Start / Stop Key and LED

The 'Start / Stop' key is used to control the following functions:-

- Cancelling Buzzer (All Modes).
- Starting Core Temp Mode (Core Temp Mode).
- Starting Timer (Manual Mode).
- Pausing Timer (Manual / Program Modes).
- Resetting Timer (Manual Mode).
- Starting Program (Program Mode).
- Cancelling Program (Program Mode).

Core Probe Connection Point

Starting the Oven

1. Turn 'On' electrical power to the oven. The controller will carry out a self check of the LED's.
2. Press the 'On / Off' key.
3. The Heating 'On' Indicator will illuminate and the oven will heat to the pre-programmed pre-heat temperature.

Oven Shut-Down

1. To turn the oven 'Off', press and hold the 'On / Off' key for 3 seconds, the oven controller will go to 'Stand-By' mode.

Operation

Cooking in Manual Mode

1. SETTING OVEN TEMPERATURE.

- + to increase the temperature.
- to decrease the temperature.

NOTE: The Oven can be used without using the timer.

2. SETTING TIMER.

- + to increase the time.
- to decrease the time.

NOTE: The Timer can be set to Infinity. **Inf** If 'Timer' is set to 'Infinity', timer will count elapsed time to a max of 999 minutes and elapsed time be shown on the lower display.

3. STARTING TIMER.



Press 'Start / Stop' key to start timer operation.

Pressing the 'Start / Stop' key when timer is operating will pause the timer and turn 'Off' Fan and Heating. LED will flash when timer is paused.

Pressing and Holding 'Start / Stop' key for 3 seconds will reset the timer.

4. ADJUSTING TEMPERATURE AND TIME.

At any time during cooking, the oven temperature and time can be adjusted by using the 'Temp' and 'Timer' controls.

5. VIEWING ACTUAL OVEN TEMPERATURE.



Press 'Act Temp' key, during cooking. Actual temperature will display briefly on upper display before the display reverts to the pre-set temperature.

6. MOISTURE MODE / STEAM.



Press 'Steam' key, to turn the Moisture Mode 'On' or 'Off' at any time.

'Steam' 'On' LED will illuminate when Moisture Mode is 'On'.

When Moisture Mode is 'On', steam will be injected at the pre-set level.

(Refer to 'Moisture Mode' section, for moisture level adjustment).

NOTE:

- In Moisture Mode, steam injection will only occur when a Timer is started / running.
- If a Timer is not running, the Moisture Mode is not active.

7. CHANGING FAN SPEED.



Press 'Fan Lo' key, to change fan speed. 'Fan Lo' indicator will illuminate when fan low speed is selected.

8. CANCELLING TIME UP BUZZER (Cooking Time completed).



When the set Cooking Time is completed, the buzzer will sound and lower display flashes. Press Start / Stop key to cancel buzzer.

NOTE: The oven will continue to cook at the Oven Set Temperature.



Operation

Cooking in Core Temp Mode (Requires Optional Core Temp Probe Kit #236060).

Entering the Core Temperature Cooking Mode

1. CONNECT CORE PROBE.

Connect the Core Probe to the connector on the lower right side of the control panel.

 will be displayed on the lower display.

2. SET OVEN TEMPERATURE.

- + to increase the temperature.
- to decrease the temperature.

3. SET CORE PROBE TEMPERATURE.

- + to increase the temperature.
- to decrease the temperature.

- **Min Core Probe Temp = 50°C / 122°F.**
- **Max Core Probe Temp = 90°C / 195°F.**

The lower display will alternately flash between  and the set core probe temperature, once temperature is set.

4. START CORE TEMP MODE COOKING.



Press 'Start / Stop' key to start Core Temp Mode cooking operation.

The lower display will alternately flash between  and the set core probe temperature during cooking.

5. ADJUSTING TEMPERATURES.

At any time during cooking, the oven and core set temperatures can be adjusted by using the 'Temp' and 'Timer' controls.

6. VIEWING ACTUAL OVEN AND CORE TEMPERATURES.



Press 'Act Temp' key, during cooking to check 'Actual' temperature of oven on upper display and 'Actual' temperature of Core Probe, on lower display.

7. ADDING MOISTURE / STEAM (If required).



Press 'Steam' key, to turn the Moisture Mode 'On' or 'Off' at any time. 'Steam' 'On' LED will illuminate when Moisture Mode is 'On'. When Moisture Mode is 'On', steam will be injected at the pre-set level.

(Refer to 'Moisture Mode' section, for moisture level adjustment).

NOTE:

- In Moisture Mode, steam injection will only occur when a Timer is started / running.
- If a Timer is not running, the Moisture Mode is not active.

8. CHANGING FAN SPEED (If required).



Press 'Fan Lo' key, to change fan speed. 'Fan Lo' indicator will illuminate when fan low speed is selected.

9. CANCELLING CORE TEMP BUZZER (Core Temp Setting reached).



When the set Core Probe temperature is reached, the buzzer will sound and lower display flashes. Press Start / Stop key to cancel buzzer.

NOTE: The oven will continue to cook at the Oven Set Temperature and the Set Core Temperature will still be shown on the lower display.

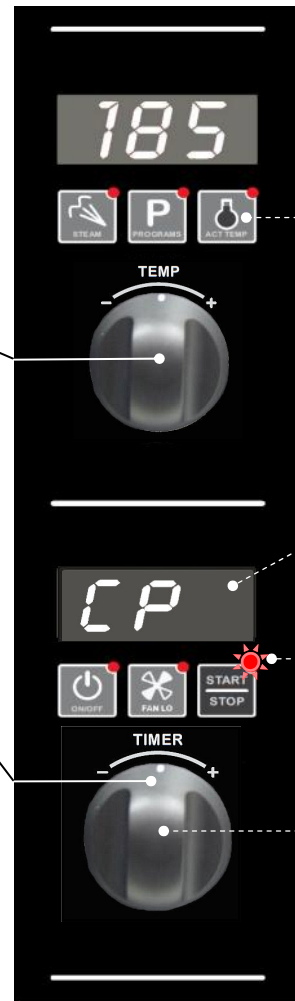

In Core Temp Mode, pressing 'Act Temp' key will also display Actual Core Probe temperature in the lower display.

In Core Temp Mode, the lower display will show Core Probe connected and Core Probe Temperature.

'Start / Stop' LED is 'On' when Cook Mode in Progress.

In Core Temp Mode, the Timer Knob is used to set Core Probe Temperature.

Exiting the Core Temperature Cooking Mode.

- Disconnect the Core Probe from the connector on the lower right side of the control panel.
- Lower Display and Timer Control Knob will revert to normal Timer Mode operation.

Moisture Mode

Moisture Mode Settings

The Moisture Mode can be pre-set to 5 levels of moisture / steam injection.

The setting level sets the number of steam injection pulses that occur in the oven during operation.

- H-0** The moisture mode is disabled.
- H-1** Level 1 - Minimum moisture/steam injection setting.
- H-2** Level 2.
- H-3** Level 3.
- H-4** Level 4.
- H-5** Level 5 - Maximum moisture/steam injection setting.

NOTE: Moisture Mode will only operate when a Timer is running in Manual or Program Modes, or when the Core Temp Mode is running.

Setting Moisture Mode Pre-Set Level



Press and hold the **STEAM** Key until the '**H-X**' level is displayed and flashing in the upper display.

Rotate the **TEMP** Knob -/+ to select Moisture Mode level required.



Press the **STEAM** Key to confirm setting.

Changing the Moisture Mode Level

The Moisture Mode level can be changed at anytime during operation by following the setting method as described above.

Using Moisture Mode



Press the **STEAM** key to activate Moisture Mode.

The STEAM key LED will illuminate when Moisture Mode is 'On'.

Moisture Mode will operate at the preset level during the cooking cycle.

NOTE: Moisture Mode will only operate when a Timer is running in Manual or Program Modes, or when Core Temp Mode is running.

Core Probe - Use Guide

With core probe cooking, it is important to position the probe in the very centre of the food. The probe should always be positioned from the top downwards at the centre of the food to be cooked.

In pieces whose thickness is less than twice the probe length, the probe should be inserted horizontal to the table top so that the tip of the probe is located in the middle of the food (see second figure).

The probe measures the temperature at the centre of the food.

It is also recommended that the food, with the probe inserted, is placed into the centre of the oven.

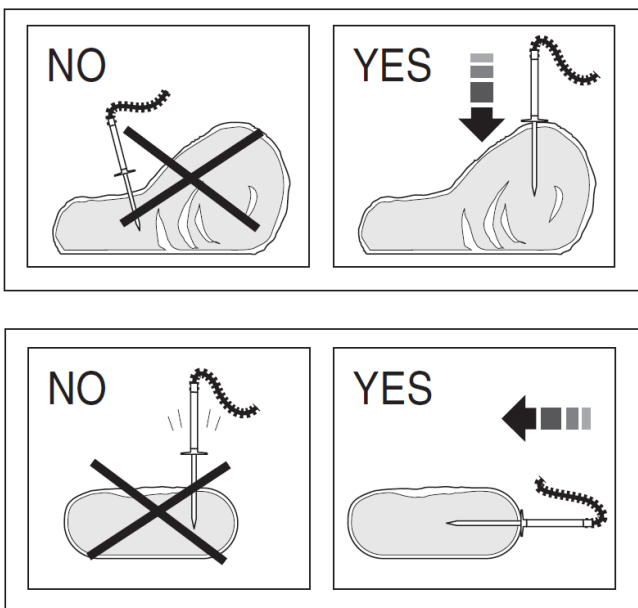

Advantages of Core Probe Cooking

- Improves control over the cooking process, eliminating the risk of loss and waste.
- Permits accurate cooking irrespective of the quality or size of the product.
- Saves time because cooking control is automatic.
- Guarantees strict hygiene because, with precision monitoring of the core temperature, there is no need for food to be handled, poked or pierced.
- Ideal for large items of food.

Operation

Cooking in Program Mode

1. SELECTING A PROGRAM.



Press 'Programs' key.

Upper Display will show program number selected.

- + to scroll forward through programs.
- to scroll backward through programs.

Lower Display will show **P-H**, oven is 'Pre-Heating'.
Program cannot be started until pre-heating is completed.

2. OVEN READY.

Lower display will show **rdy** when oven is up to pre-heat temperature and a buzzer will sound.

Load product into oven.

3. START PROGRAM.



Press 'Start / Stop' key to start cooking program.

- Pressing the 'Start / Stop' key when timer is operating will pause the timer and turn 'Off' Fan and Heating. LED will flash when timer is paused.
- Pressing and Holding 'Start / Stop' key for 3 seconds will cancel the program and return to Preset Program.

4. PROGRAM 'TIME UP' / BUZZER (Cooking Time completed).



When the programmed Cooking Time is completed, the buzzer will sound. Press Start / Stop key to cancel buzzer.

NOTE: The oven will continue to cook at the Oven Set Temperature.

4. ADDITIONAL ADJUSTMENTS (These can be adjusted whilst Program Mode is running).

NOTE: Adjustments made during cooking will not be saved to the program.

A. Adjusting the Temperature and Time.

At any time during cooking, the oven temperature and time can be adjusted by using the 'Temp' and 'Timer' controls.

B. Viewing Actual Oven Temperature.



Press 'Act Temp' key, during cooking. Actual temperature will display briefly on upper display before the display reverts to the program selected.

C. Moisture Mode (If not already part of Program).



Press 'Steam' key, to turn the Moisture Mode 'On' or 'Off' at any time. 'Steam' 'On' LED will illuminate when Moisture Mode is 'On'. When Moisture Mode is 'On', steam will be injected at the pre-set level.
(Refer to 'Moisture Mode' section, for moisture level adjustment).

NOTE:

- In Moisture Mode, steam injection will only occur when a Timer is started / running.
- If a Timer is not running, the Moisture Mode is not active.

D. Changing Fan Speed (If not already part of Program).



Press 'Fan Lo' key, to change fan speed. 'Fan Lo' indicator will illuminate when fan low speed is selected.

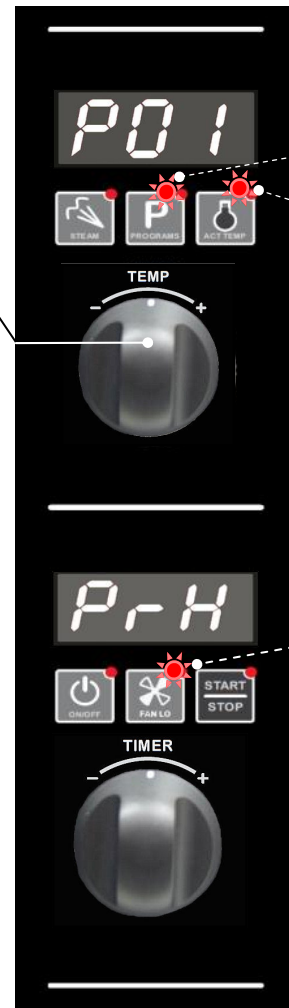

Program Mode LED is 'On' when Oven operating in 'Program Mode'.

Heating 'On' LED will remain 'On' until oven reaches set temperature.

'Lo Fan' LED is 'On' when Lo Speed Fan is 'On'.

Operation

Oven Programs - Programming

Oven can be pre-programmed with up to 20 Program's. When you receive your oven, the controller is not pre-programmed. To set programs, carry out the following for each program required:-

1. SELECT PROGRAMS MODE.



Press '**Programs**' key to enter 'Programming' mode.
'Programs' LED will illuminate.

2. SELECT PROGRAM REQUIRED (P01 - P20).

Rotate '**Temp**' Knob to program required.
Upper display will show program selected.

3. ENTER PROGRAMMING MODE.



Press and hold 'P' key until temperature flashes in the **Upper display**.

4. SET TEMPERATURE (60°C - 260°C / 140°F - 500°F).

Rotate '**Temp**' Knob to select temperature required.

- + to increase the temperature.
- to decrease the temperature.



Press 'P' key to confirm temperature setting.
Controller will step to **Cook Time** setting.

5. SET TIME (INF - 180 Mins).

Lower display flashing.

Rotate '**Timer**' Knob to select time required.

- + to increase the time.
- to decrease the time.



Press 'P' key to confirm time setting.
Controller will step to **Moisture / Steam Option** setting.

6. SET MOISTURE / STEAM OPTION (H-0 - H-5).

Upper display flashing.

Rotate '**Temp**' Knob to select moisture / steam setting required.

- + to increase the moisture / steam level.
- to decrease the moisture / steam level.

(Refer to Sub-section, 'Moisture Mode', for moisture level adjustment).



Press 'P' key to confirm moisture / steam setting.
Controller will step to **Fan Speed Option** setting.

7. SET FAN SPEED OPTION (LO - HI).

Upper display flashing. **FAN**

Rotate '**Temp**' Knob to select fan option required.



Press 'P' key to confirm fan option. Buzzer will sound.
Controller will return to the program selected at Item 2 above.

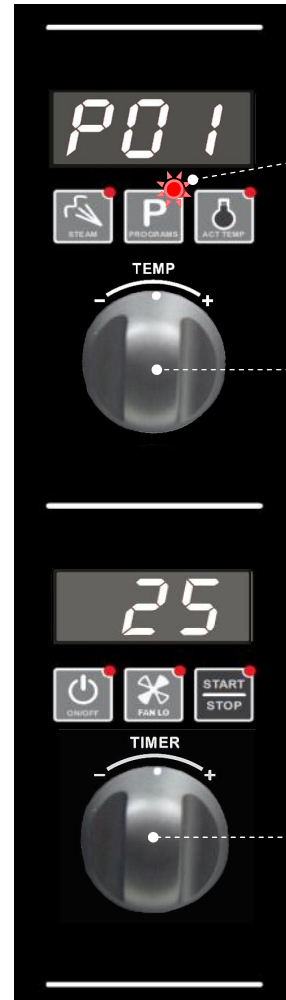

Programs Mode LED is 'On' when Oven is operating in 'Programs Mode'.

In Programs Mode,
Temp Knob is used to select:-
Program.
And to set:-
Cook Temperature.
Moisture Level.
Fan Speed Option.

In Programs Mode,
Timer Knob is used to set:-
Program Time.

Controller - User Settings

User Settings

PrH

Oven Pre-Heat; - (Automatic pre-heat temp on oven start-up).

Factory default pre-heat setting is 150°C/302°F. In 'User Settings' the temperature setting can be changed to user preference. **Setting Range, 60 - 260°C / 140 - 500°F.**

uol

Buzzer Volume; -

Factory default buzzer volume is set to Level 5. In 'User Settings', the buzzer volume can be changed to user preference. **Setting Range Levels, 0 -10.**

PrE

Pre-Heat Ready; - This setting allows for the pre-heating 'Ready' temperature in 'Program Mode' mode to be set higher than the Program Set Temperature. The Factory Default setting is '0' (Equal to Program Setting).

Setting Range for Pre-Heat above Set Point is, 0-30°C / 0-30°F

Changing User Settings

With the Oven in 'Stand-By' Mode:-

1. ENTER OPERATOR PARAMETER MODE.



Press 'Steam' and 'Start / Stop' keys together.

Upper Display will show **PrS** .

Lower Display will flash **000** .

2. SET PASSWORD (Operator Password - 123).

Rotate 'Timer' Knob to set password **123** .



Press 'Fan Lo' key to confirm password.

Upper Display will show one of the **Parameter Codes PrH** .

Lower Display will show the value of the parameter **185** .

3. SETTING THE PARAMETERS.

Rotate 'Timer' Knob to the parameter required.



Press 'Fan Lo' key to confirm parameter. 'Time' display will flash.

While **Lower Display** is flashing, rotate 'Timer' Knob to select value required.



Press 'Fan Lo' key to confirm value. **Lower Display** will stop flashing.

4. EXITING THE PARAMETER MODE.



Press 'On-Off' key, to return to 'Stand-By' mode.



Cleaning and Maintenance

Cleaning Guidelines



Caution

Always turn 'Off' electrical power at the mains supply before commencing cleaning.

This oven is not water proof. Do not use water jet spray to clean interior or exterior of the appliance.

To achieve the best results, cleaning must be regular and thorough. If any small faults occur, have them looked at promptly. Don't wait until they cause a complete breakdown.

NOTE:

- Carefully read and follow the safety instructions on the label of the cleaning product to be used.
- DO NOT use harsh abrasive scouring pads or abrasive detergents as they could damage the oven.
- Ensure that any detergent or cleaning material has been completely removed after each cleaning.

To keep your oven clean and operating at peak efficiency, follow the procedures shown below:-

Oven Cleaning

NOTE:

- If oven usage is very high, the cleaning procedure should be carried out more frequently.
- Allow the oven interior to cool to approx 50°C / 120°F before commencing cleaning.

Stainless Steel Surfaces

- Thoroughly clean the exterior surfaces of the oven with, a damp cloth moistened with a mild detergent solution, or a soft bristled brush.
- Baked on deposits or discolouration may require a good quality stainless steel cleaner. Always apply cleaner when the oven is cold and rub in the direction of the grain.

Side Racks Removal

Right Rack / Fan Baffle

- Lift up and unhook the RH side rack from the locating pegs on the RH side of the oven. The fan baffle is an integral part of the RH Side Rack.



- Tilt the top of the rack inwards and lift the rack off the lower mounting brackets.

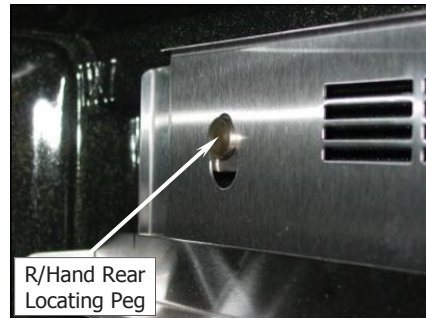

Left Rack

- Lift the LH rack off the front locating peg.



- Pull the rack forward out of the oven to disengage the rear of the rack from the rear location peg and remove the rack from the oven.



- Clean the racks with a mild anti bacterial detergent and hot water, using a soft bristled brush.
- Dry the racks thoroughly with a dry cloth.

Cleaning and Maintenance

Side Racks Re-Fitting

Right Rack

- Align the bottom of the rack with the 2 brackets in the bottom RH side of the oven.

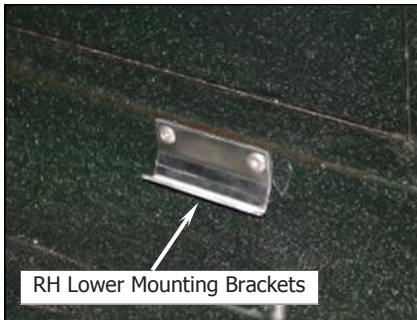

- Tilt the rack upwards and hook the top of the rack onto the locating pegs in the top of the oven.

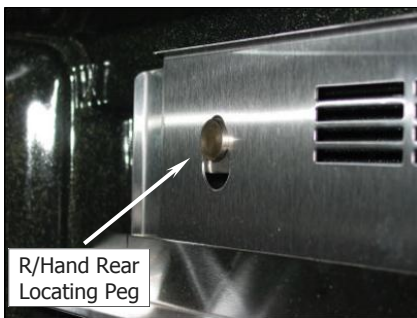

Left Rack

- Locate the top rear of the rack onto the locating peg at the top rear LH side of the oven.



- Locate the top front of the rack over the locating peg at the top front LH side of the oven.

Oven Lamp

- Remove the LH side rack as shown previously.



- Remove the 4 screws securing Support Frame, Gasket and Glass Lens to the light fitting and carefully remove items, taking care as glass lens is a loose fit in the support frame.

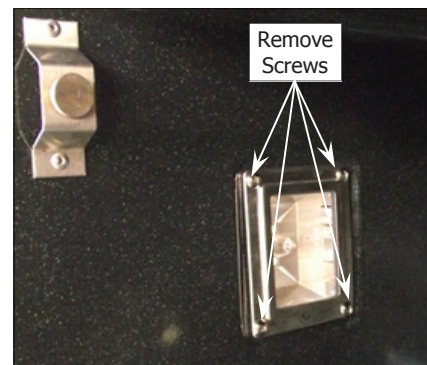

- Wash the glass lens and gasket with a soft sponge using warm water and a detergent solution. Rinse with clean, warm water.

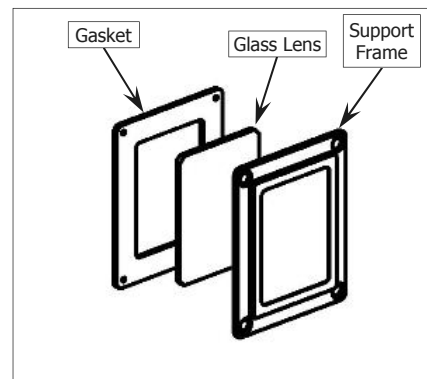

- Dry the glass lens and gasket thoroughly with a dry cloth. Refit glass lens to the support frame. Place gasket over the glass lens.
- Fit the 4 screws through the support frame and gasket to hold gasket and glass lens in place.
- Refit the assembly to the oven and carefully tighten the securing screws ensuring that the seal is within the support frame. Tighten screws hand tight only.

NOTE: Do not over tighten lamp securing screws as over-tightening can cause glass lens to break.

- Refit LH side rack as shown previously.

Cleaning and Maintenance

Door Seal

- a. To remove the door seal, pull the 1 piece seal forward until it pulls out of the location groove around the oven. **Note the way the seal is fitted to the oven, with the lip facing inwards.**



- b. Check the door seal for wear and damage and replace as required.
- c. Wash the door seal in a sink, taking care not to cut or damage the seal.
- d. Dry the door seal thoroughly.
- e. Refit the door seal with lip facing into centre of the oven.



- f. Press the door seal into the locating groove in the front face of the oven until the seal is properly located all around the oven.

Oven Interior

- **Allow the oven interior to cool to approx 50°C / 120°F before commencing cleaning.**
 - a. Remove the oven racks as shown previously.
 - b. Clean any build up of grease from the oven interior, using a soft bristled brush with a solution of hot water and a mild anti bacterial detergent.
 - c. Dry the oven thoroughly with a soft dry cloth.
 - d. Clean the oven regularly with a good quality oven cleaner.

Door Glass Cleaning

- **Ensure that the oven door is cool before cleaning the oven door glass.**

- a. Open the oven door.
- b. Lift up the bottom of the inner glass at the centre of the door to unlock from the inner glass retaining catches and swing the glass inwards towards the oven.

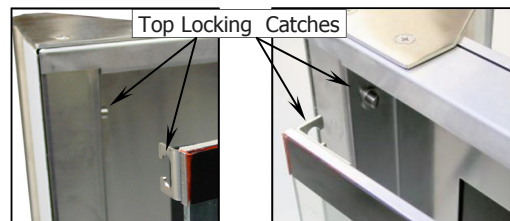
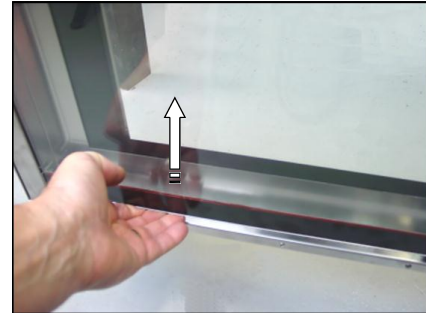

- c. Clean both sides of the inner glass and the inner side of the outer door glass with a conventional glass cleaner.
- d. Dry the oven door thoroughly with a soft dry cloth.
- e. Swing the inner glass back towards the outer door.
- f. Whilst holding the outer door, lift the inner glass back onto the locking catches until the inner glass is securely held.

Periodic Maintenance

NOTE: All maintenance operations should only be carried out by a qualified service person.

Controls and mechanical parts should be checked and adjusted periodically by a qualified service person. It is recommended that the appliance is serviced every 6 months.

Fault Finding

This section provides a reference to the more common problems that may occur during the operation of your oven. This fault finding guide is intended to help you correct and accurately diagnose problems with your oven.

You may encounter a problem not covered in this section, please contact your service provider who will require the following information:-

When fault finding a problem, always use a process of elimination starting with the simplest solution and working through to the most complex. Never overlook the obvious.

- **The Model and Serial Number of the oven, can be found on the Technical Data Plate located on the front right hand side panel of the oven.**

Fault	Possible Causes	Remedy
Oven does not operate.	Mains isolating switch, circuit breaker or fuses are 'Off' at the power board.	Turn 'On'.
	Overtemp tripped (No lights, no power light).	Call for service.
	Overtemp faulty.	Call for service.
	Digital Controller faulty	Call for service.
	Element faulty.	Call for service.
Oven Controller operates but No Heat in Oven.	Digital Controller faulty	Refer to 'Digital Controller Fault Codes'. Call for service.
	Door not closed fully (display shows ' dor ').	Close door. (Refer 'Door does not close fully').
	Door Switch faulty (display shows ' dor ').	Call for service.
Oven heats up but Fan does not operate.	Heating Contactor faulty.	Call for service.
	Fan motor faulty.	Call for service.
	Fan or fan motor obstructed.	Call for service.
	Controller faulty.	Call for service.
	Fan Contactor faulty.	Call for service.
Oven does not Steam.	Fan Capacitor faulty.	Call for service.
	Steam Mode not selected.	Check Steam Mode settings.
	Injector Nozzle blocked.	Call for service.
	Water Solenoid faulty.	Call for service.
Door does not close fully.	Controller faulty.	Call for service.
	Tray in way of door (display shows ' dor ').	Correctly position tray in rack.
	Door misaligned (display shows ' dor ').	Re-align door.
Oven light not illuminating.	Door seal obstruction (display shows ' dor ').	Correctly install door seal. (Refer to the 'Cleaning' Section).
	Blown bulb (one bulb not working).	Call for service.
Uneven cooking.	Blown fuse (both bulbs not working).	Call for service.
	Too high a temperature selected.	Select a lower temperature.
	Oven or racks not level.	Check oven racks and level.
	Insufficient air space around trays or baking tins.	Ensure oven racks are spaced to allow air flow around baking on all shelves.
	Oven overloaded with too much product.	Re-load oven.
	Opening oven door un-necessarily.	Ensure oven door is closed during baking.
	Oven door seal damaged or faulty.	Check seals and replace if damaged.
	Oven vent restricted.	Ensure oven vent not blocked or shrouded.
Control Panel does not indicate 'CP' when Core Probe connected.	Core Probe Faulty	Replace Core Probe.
'Err 001' on display.	Probe failure.	Call for service.
'Err 003' on display.	Motor Thermal Cut-Out tripped.	Call for service.

Electrical Schematics

Electrical Schematic E33D5 Turbofan Oven

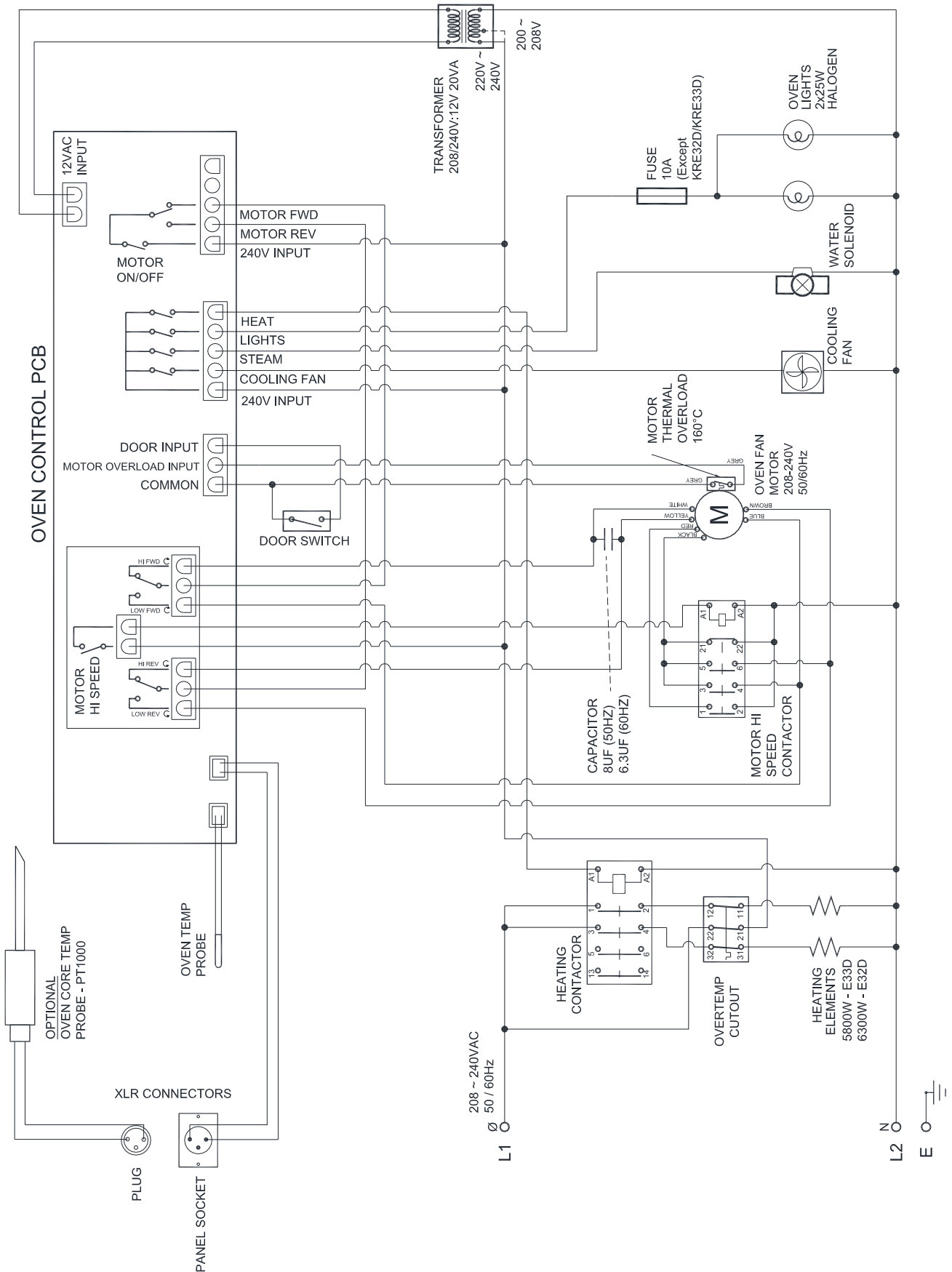

Replacement Parts List

Important:

**Only genuine authorized replacement parts should be used for the servicing and repair of this oven. The instructions supplied with the parts should be followed when replacing components.
For further information and servicing instructions, contact your nearest authorized service provider or Turbofan Dealer.**

When ordering replacement parts, please quote the part number and the description as listed below. If the part required is not listed below, request the part by description and quote model number and serial number which is shown on the Technical Data Plate.

Item	Description
236256	Digital Control Board Kit E33D.
234429	Transformer, 208 / 240V x 12V AC SEC, 20VA.
234460	Cooling Fan 230V.
234434	Oven Temperature Probe.
234821	Overtemp Thermostat 355°C / 670°F.
231738	Contactora - Heating.
231742	Contactora - Motor Speed.
236109	Oven Element, 5800W, 230 - 240V.
236110	Oven Element, 5800W, 208 - 220V.
236264	Element Gasket (included in Oven Element Kit).
235625	Fan Motor, 2 Speed.
235610	Motor Shaft Seal.
234138	Fan - Dia 8½" / 220mm.
236053	Motor Capacitor 6.3uF, 60Hz Only.
236054	Motor Capacitor 8uF, 50Hz Only.
021352	Oven Glass Lens.
231814	Lamp Bulb G9 25W, Halogen, 230V.
021354	Oven Lamp Gasket.
234803	Fuse 10A, 250V.
234447	Control Knob.
020851	Water Solenoid.
021057	Spray Nozzle Assembly.
235615	Oven Door Seal - E33.
235652	Door Inner Glass Assembly.
235859	Door Handle Assembly.
231804	Single Step Locking Dog.
235851	Door Hinge Set Top
235852	Door Hinge Set Bottom
232379	Foot Adjustable (73 - 80mm).
232380	O-Ring.
235669	Side Rack LH, 5 Tray - E33.
235670	Side Rack RH, 5 Tray - E33.
236057	Oven Rack - E33.

Optional Extras

Item	Description
236060	Core Temperature Probe Kit.
235845	Core Temperature Probe.
235847	Dust Cap - Core Temperature Socket.
236271	Core Temperature Probe Holder.