



Job: _____

Item No. _____

DESIGNED FOR HIGHER VOLUME APPLICATIONS

Three – 12 oz. Shakes per Minute – 20 Quart Capacity

GREAT FOR QUICK SERVICE RESTAURANTS AND DRIVE-THRUS

The **SaniServ** model 601 Shake Freezer provides a high volume of smooth quality shakes! With its increased production and recovery time, owners and operators can always provide plenty of high profit shake product, even during peak operating periods. As always, adding an optional Drink Spinner and Syrup Rail for flavors can create customer favorites. The 601 provides customer satisfaction every time by insuring their favorite shakes are always available!

SPACE SAVING

Small Footprint Design - **SaniServ** model 601 saves valuable floor space and turns the countertop into a real profit center by serving a large volume of high profit shake beverages.

EASY CLEANING AND OPERATION

Fewer Parts = Simplified Cleaning – **SaniServ** equipment is designed and built with fewer parts to be disassembled, cleaned and sanitized than any other machine in the industry. The state of the art solid-state **AccuFreeze** control insures product consistency, worry-free operation and customer satisfaction.

HIGH RETURN ON INVESTMENT

Increased Profits – **SaniServ** machines combine efficiency with consistent product quality and fast, quiet operation while insuring customer satisfaction with high profit ice cream or yogurt products.

QUALITY DESIGN

Durability – **SaniServ** machines are built to achieve long and dependable life through simplicity of design. Every machine is shipped standard with a stainless steel exterior, durable steel interior frame construction, heavy-duty components and consistency systems.

Model 601

Counter Model

Shake Machine

With *AccuFreeze* control



Made in USA

We reserve the right to change specifications and product designs without notice. Such revisions do not entitle the buyer to corresponding changes, improvements, additions or replacements for previously purchased equipment.

451 E. County Line Rd. • P.O. Box 1089 • Mooresville, IN 46158
Toll Free 800-733-8073 • Local 317-831-7030 • Fax 317-831-7036
www.saniserv.com

MODEL 601

Counter Model Shake Freezer

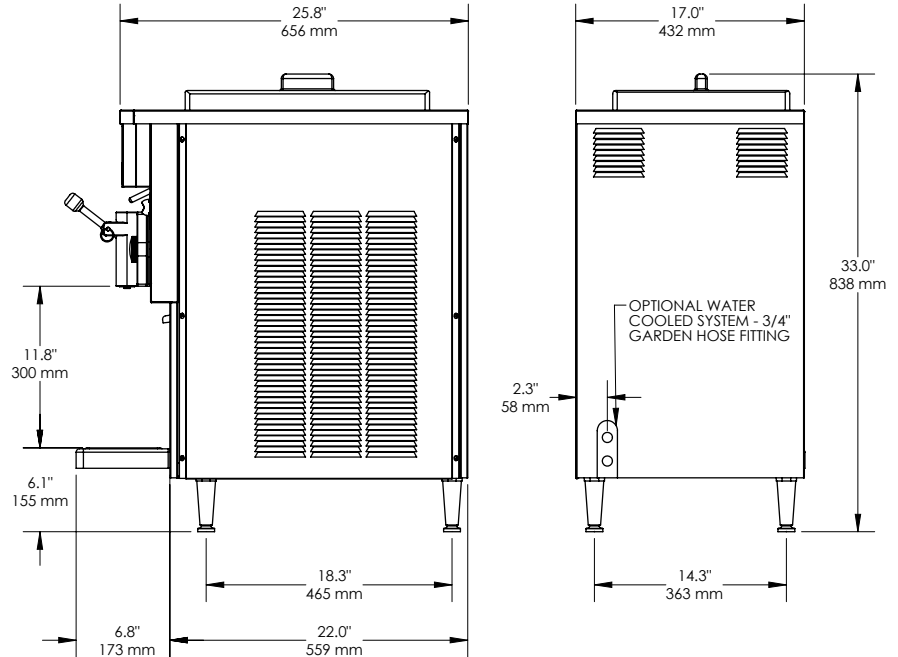
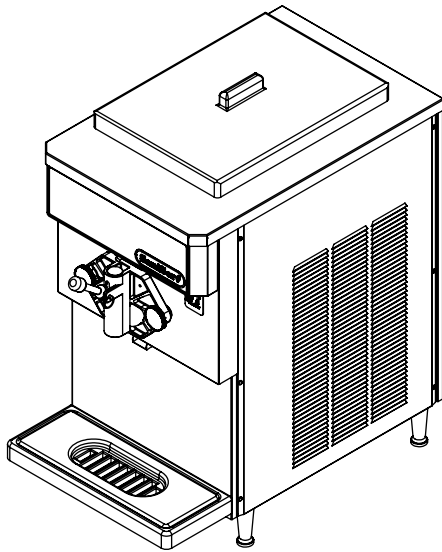

Minimum Wall Clearance
Both Sides and Back -
6 inches (152 mm)

ELECTRICAL				WIDTH	HEIGHT	DEPTH	WEIGHT	VOLUME
VOLTS	Hz	Ph.	Amps	INCHES (MM)	INCHES (MM)	INCHES (MM)	LBS. (Kg)	CU FT. (cu. m.)
208-230	60	1	20	17 (432)	33 (838)	28 (656)	242 (110)	
208-230	60	3	15					
Shipping Specifications				22.5 (572)	41 (1042)	34.5 (876)	275 (125)	18.5 (.53)

Specifications:

Cooling System:
Air or Water

Dasher and Compressor Motors:
1/4 HP Dasher
1 HP Compressor

Refrigerant Type:
R404A

Listings:
UL, cUL, NSF

Features:

Evaporator and Mix Reservoir
Capacity:
20 Quarts (18.9 liters)

Dasher:
Heavy-Duty Stainless Steel with low friction scraper blades.

Controls:
AccuFreeze solid-state control for accurate product consistency.

Solid State Audio/Visual Mix Out System with Compressor Lockout

Warranty:

Parts 1 year
Compressor 5 years
Evaporator 5 years

Options:

Tune Up Kit
Parts Tray
Syrup Rail
Counter Top Mounting Pad Machine Stand
Water Cooled - 3/4" Garden Hose Fitting
Wash Out Kit - 3/8" Flare Fitting
Export Voltages
Drink Spinner

451 E. County Line Rd. • P.O. Box 1089 • Mooresville, IN 46158
Toll Free 800-733-8073 • Local 317-831-7030 • Fax 317-831-7036

www.saniserv.com

REV 03-2015