

FEATURES

- Stainless steel body & interior with aluminum back
- Stainless steel insulated door
- Fan forced cooling system
- Self-evaporation water tray
- 1 heavy duty epoxy coated shelf
- Includes 10.25" deep sanitary cutting board
- Includes 4" heavy duty locking casters
- Space for 8 PCs of 1/6 size pan inserts (poly carbonate pans included)
- Self-closing swing doors with 90 degree stay open feature
- Digital temperature controller & defrost timer
- Heavy duty 1/5 HP Embraco compressor



SPT-28-8

TEMPERATURE

- Interior temperature range: 0°C to 8°C (32°F to 46°F)

WARRANTY

- 2 years parts and labour
7 years compressor warranty
- Extended warranty options available

Project: _____

Date: _____

Price: _____

Model SPT-28-8

Refrigerated Sandwich Prep Table

SPECIFICATIONS

Volts (V)	Watts (W)	Amps (A)	Volume (cu./ft)	Refrigerant	Overall Dimensions			Interior Dimensions			Weight	
					Width	Depth	Height	Width	Depth	Height	Net	Gross
115V	333W	2.9A	5.7	R290	27.5	29.5	42.5	N/A	N/A	N/A	187 LBS	N/A

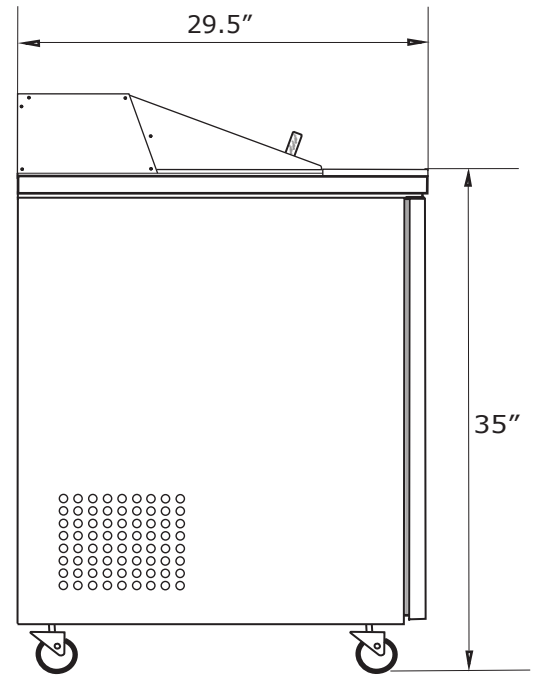
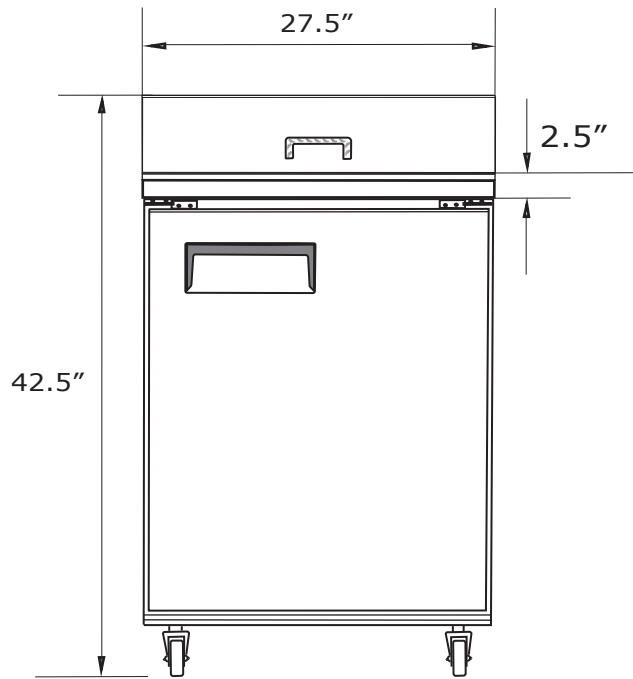

Refrigerated Sandwich Prep Table

Model SPT-28-8

CERTIFICATIONS:

