

FEATURES

- High quality stainless steel body & interior
- Top surface has beveled edges to keep equipment securely on the base & contain drips and spills for easy cleanup
- 2 Stainless steel drawers
- Fan forced cooling system
- Self-evaporation water tray
- Each drawer fits 2 PCs of full size & 3 PCs of 1/6 size inserts, 4" deep (pans not included)
- Includes 4" heavy duty locking casters
- Removable condensing unit for easy cleaning & service
- Dixell digital temperature controller & defrost timer
- Heavy duty 1/6 HP Embraco compressor



RCB-48

TEMPERATURE

- Interior temperature range: 0°C to 8°C (32°F to 46°F)

WARRANTY

- 2 years parts and labour
7 years compressor warranty
- Extended warranty options available

Project: _____

Date: _____

Price: _____

SPECIFICATIONS

Volts (V)	Watts (W)	Amps (A)	Volume (cu./ft)	Refrigerant	Overall Dimensions			Interior Dimensions			Weight	
					Width	Depth	Height	Width	Depth	Height	Net	Gross
115V	402W	3.5A	8.8	R290	48.5	32	25.5	N/A	N/A	N/A	196 LBS	240 LBS

Refrigerated Chef Base

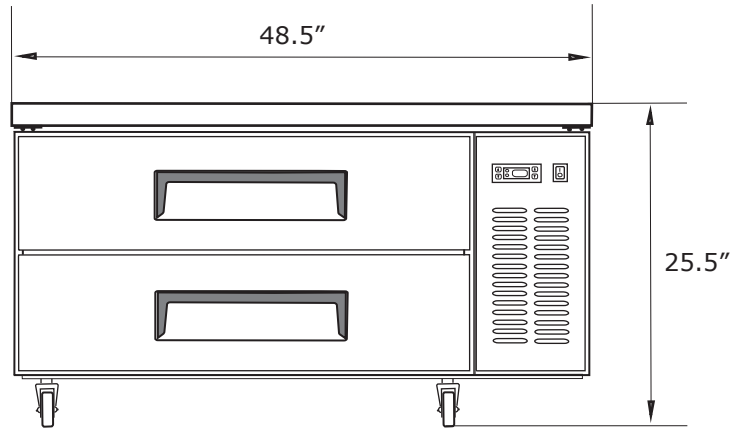

Model RCB-48

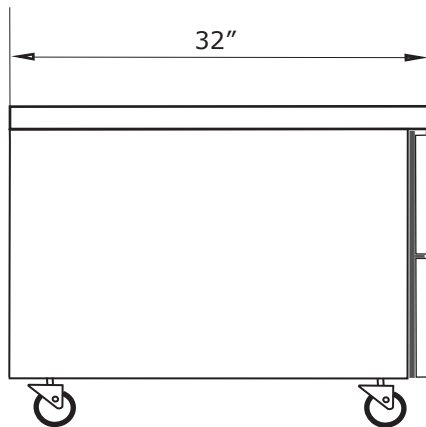

CERTIFICATIONS:



NEMA 5-15P