

FEATURES

- High quality stainless steel body & interior
- Top surface has beveled edges to keep equipment securely on the base & contain drips and spills for easy cleanup
- 2 Stainless steel drawers
- Fan forced cooling system
- Self-evaporation water tray
- Each drawer fits 1 PC of full size & 3 PCs of 1/6 size inserts, 4" deep (pans not included)
- Includes 4" heavy duty locking casters
- Removable condensing unit for easy cleaning & service
- Dixell digital temperature controller & defrost timer
- Heavy duty 1/6 HP Embraco compressor



RCB-36

TEMPERATURE

- Interior temperature range: 0°C to 8°C (32°F to 46°F)

WARRANTY

- 2 years parts and labour
7 years compressor warranty
- Extended warranty options available

Project: _____

Date: _____

Price: _____

SPECIFICATIONS

| Volts (V) | Watts (W) | Amps (A) | Volume (cu./ft) | Refrigerant | Overall Dimensions | | | Interior Dimensions | | | Weight | |
|-----------|-----------|----------|-----------------|-------------|--------------------|-------|--------|---------------------|-------|--------|---------|---------|
| | | | | | Width | Depth | Height | Width | Depth | Height | Net | Gross |
| 115V | 287W | 2.5A | 5.9 | R290 | 36.5 | 32 | 25.5 | N/A | N/A | N/A | 154 LBS | 198 LBS |

Refrigerated Chef Base

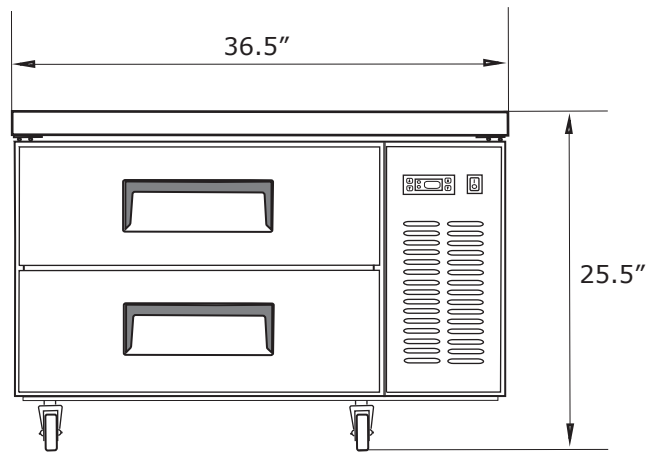

Model RCB-36

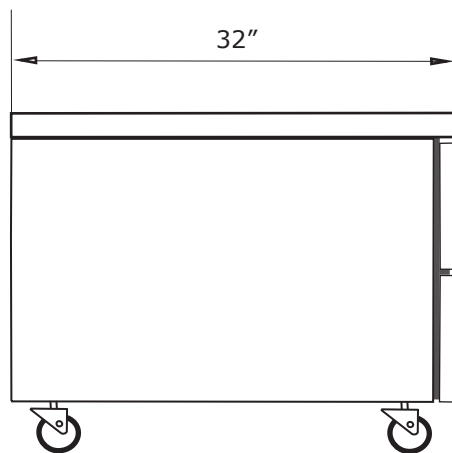

CERTIFICATIONS:



NEMA 5-15P