

FEATURES

- High quality stainless steel body & interior, aluminum back
- Stainless steel insulated door
- Side mounted compressor & condensing unit
- Fan forced cooling system
- Self-evaporation water tray
- 1 heavy duty epoxy coated shelf
- Includes 19.5" deep sanitary cutting board
- Includes 4" heavy duty locking casters
- Space for 6 PCs of 1/3 size pan inserts (poly carbonate pans included)
- Self-closing swing doors with 90 degree stay open feature
- Digital temperature controller & defrost timer
- Heavy duty 1/6 HP Embraco compressor



TEMPERATURE

- Interior temperature range: 0°C to 8°C (32°F to 46°F)

WARRANTY

- 2 years parts and labour
7 years compressor warranty
- Extended warranty options available

Project: _____

Date: _____

Price: _____

Model PPT-44-6

Refrigerated Pizza Prep Table

SPECIFICATIONS

Volts (V)	Watts (W)	Amps (A)	Volume (cu./ft)	Refrigerant	Overall Dimensions			Interior Dimensions			Weight	
					Width	Depth	Height	Width	Depth	Height	Net	Gross
115V	264W	2.3A	7.6	R290	44.5	31.5	43	N/A	N/A	N/A	340 LB	N/A

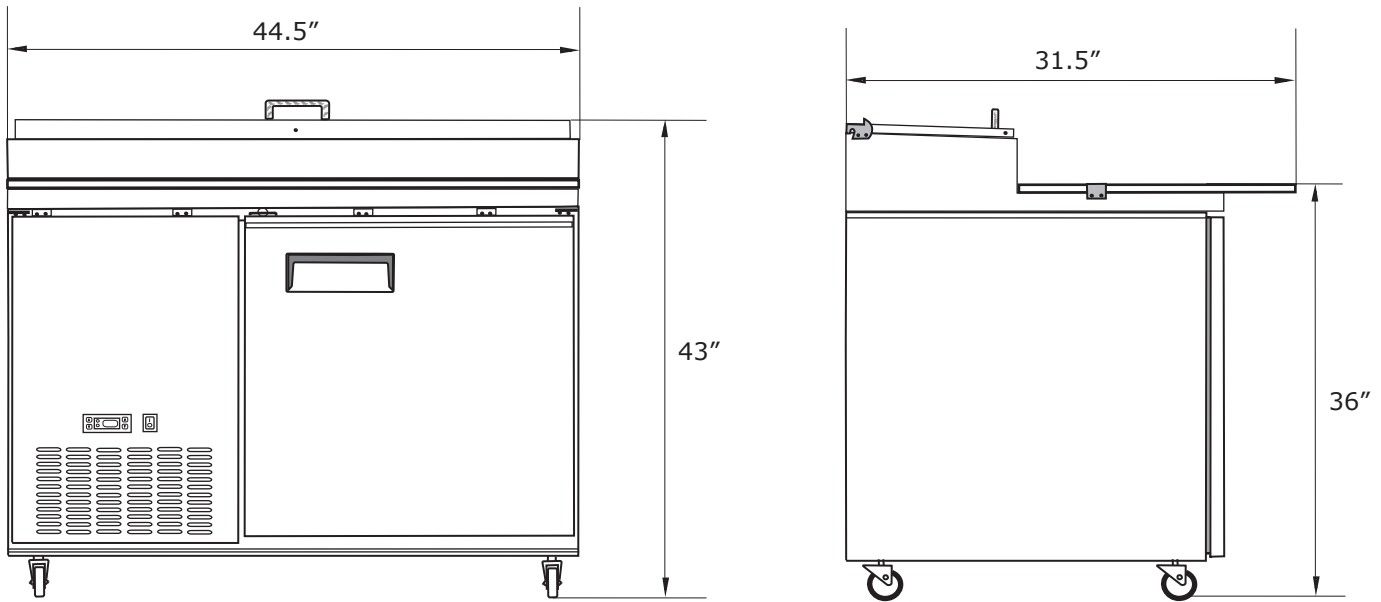

Refrigerated Pizza Prep Table

Model PPT-44-6

CERTIFICATIONS:

