



Portable Hand Sink
Item 46788
Instruction Manual



Revised - 03/22/2023

Toll Free: 1-800-465-0234
Fax: 905-607-0234
Email: service@omcan.com
www.omcan.com



Table of Contents

Item 46788

Section	Page
General Information -----	3 - 4
Safety and Warranty -----	4 - 6
Technical Specifications -----	7
Installation -----	7 - 12
Operation -----	12 - 14
Maintenance -----	15 - 19
Troubleshooting -----	19 - 20
Parts Breakdown -----	21 - 23
Electrical Schematics -----	24
Notes -----	25 - 26
Warranty Registration -----	27



General Information

Omcan Manufacturing and Distributing Company Inc., Food Machinery of America, Inc. dba Omcan and Omcan Inc. are not responsible for any harm or injury caused due to any person's improper or negligent use of this equipment. The product shall only be operated by someone over the age of 18, of sound mind, and not under the influence of any drugs or alcohol, who has been trained in the correct operation of this machine, and is wearing authorized, proper safety clothing. Any modification to the machine voids any warranty, and may cause harm to individuals using the machine or in the vicinity of the machine while in operation.

CHECK PACKAGE UPON ARRIVAL

Upon receipt of an Omcan shipment please inspect for external damage. If no damage is evident on the external packaging, open carton to ensure all ordered items are within the box, and there is no concealed damage to the machine. If the package has suffered rough handling, bumps or damage (visible or concealed), please note it on the bill of lading before accepting the delivery and contact Omcan within 24 hours, so we may initiate a claim with the carrier. A detailed report on the extent of the damage caused to the machine must be filled out within three days, from the delivery date shown in the shipping documents. Omcan has no recourse for damaged products that were shipped collect or third party.

Before operating any equipment, always read and familiarize yourself with all operation and safety instructions.

Omcan would like to thank you for purchasing this machine. It's of the utmost importance to save these instructions for future reference. Also save the original box and packaging for shipping the equipment if servicing or returning of the machine is required.

Omcan Fabrication et distribution Compañie Limité et Food Machinery d'Amérique, dba Omcan et Omcan Inc. ne sont pas responsables de tout dommage ou blessure causé du fait que toute personne ait utilisé cet équipement de façon irrégulière. Le produit ne doit être exploité que par quelqu'un de plus de 18 ans, saine d'esprit, et pas sous l'influence d'une drogue ou d'alcool, qui a été formé pour utiliser cette machine correctement, et est vêtu de vêtements de sécurité approprié. Toute modification de la machine annule toute garantie, et peut causer un préjudice à des personnes utilisant la machine ou des personnes à proximité de la machine pendant son fonctionnement.

VÉRIFIEZ LE COLIS DÈS RÉCEPTION

Dès réception d'une expédition d'Omcan veuillez inspecter pour dommages externes. Si aucun dommage n'est visible sur l'emballage externe, ouvrez le carton afin de s'assurer que tous les éléments commandés sont dans la boîte, et il n'y a aucun dommage dissimulé à la machine. Si le colis n'a subi aucune mauvaises manipulations, de bosses ou de dommages (visible ou cachée), notez-le sur le bond de livraison avant d'accepter la livraison et contactez Omcan dans les 24 heures qui suivent, pour que nous puissions engager une réclamation auprès du transporteur. Un rapport détaillé sur l'étendue des dommages causés à la machine doit être rempli dans un délai de trois jours, à compter de la date de livraison indiquée dans les documents d'expédition. Omcan n'a aucun droit de recours pour les produits endommagés qui ont été expédiés ou cueilli par un tiers transporteur.

General Information

Avant d'utiliser n'importe quel équipement, toujours lire et vous familiariser avec toutes les opérations et les consignes de sécurité.

Omcan voudrais vous remercier d'avoir choisi cette machine. Il est primordial de conserver ces instructions pour une référence ultérieure. Également conservez la boîte originale et l'emballage pour l'expédition de l'équipement si l'entretien ou le retour de la machine est nécessaire.

Omcan Empresa De Fabricacion Y Distribucion Inc. Y Maquinaria De Alimentos De America, Inc. dba Omcan y Omcan Inc. no son responsables de ningun daño o perjuicio causado por cualquier persona inadecuada o el uso descuidado de este equipo. El producto solo podra ser operado por una persona mayor de 18 años, en su sano juicio y no bajo alguna influencia de droga o alcohol, y que este ha sido entrenado en el correcto funcionamiento de esta máquina, y ésta usando ropa apropiada y autorizada. Cualquier modificación a la máquina anula la garantía y puede causar daños a las personas usando la máquina mientras esta en el funcionamiento.

REVISE EL PAQUETE A SU LLEGADA

Tras la recepcion de un envio Omcan favor inspeccionar daños externos. Si no hay daños evidentes en el empaque exterior, Habra el carton para asegurarse que todos los articulos solicitados estén dentro de la caja y no encuentre daños ocultos en la máquina. Si el paquete ha sufrido un manejo de poco cuidado, golpes o daños (visible o oculto) por favor anote en la factura antes de aceptar la entrega y contacte Omcan dentro de las 24 horas, de modo que podamos iniciar una reclamación con la compañía. Un informe detallado sobre los daños causados a la máquina debe ser llenado en el plazo de tres días, desde la fecha de entrega que se muestra en los documentos de envío. Omcan no tiene ningun recurso por productos dañados que se enviaron a recoger por terceros.

Antes de utilizar cualquier equipo, siempre lea y familiarizarse con todas las instrucciones de funcionamiento y seguridad.

Omcan le gustaría darle las gracias por la compra de esta máquina. Es de la mayor importancia para salvar estas instrucciones para futuras consultas. Además, guarda la caja original y el embalaje para el envío del equipo si servicio técnico o devolución de la máquina que se requiere.

Safety and Warranty

1. Do not pump flammable or explosive liquids such as oil, gasoline, kerosene, ethanol, etc. Do not use in the presence of flammable or explosive vapors. Using this pump with or near flammable liquids can cause an explosion or fire, resulting in property damage, serious personal injury, and/or death.
2. ALWAYS disconnect the power to the pump before servicing.
3. Do not touch the motor housing during operation. The motor is designed to operate at high temperatures. Do not disassemble the motor housing.
4. Do not handle the pump or pump motor with wet hands or when standing on a wet or damp surface, or in



Safety and Warranty

water before disconnecting the power.

5. Release all pressure and drain all water from the system before servicing any component.
6. Secure the discharge line before starting the pump. An unsecured discharge line will whip, possibly causing personal injury, and/or property damage.
7. Extension cords may not deliver sufficient voltage to the pump motor. Extension cords present a life threatening safety hazard if the insulation becomes damaged or the connection ends fall into water. The use of an extension cord to power this pump is not permitted.
8. Wear safety goggles at all times when working with pumps.
9. This unit is designed only for use on 115 volts (single phase), 60 Hz, and is equipped with an approved 3-conductor cord and 3-prong grounded plug. Do not remove the ground pin under any circumstances. The 3-prong plug must be directly inserted into a properly installed and grounded 3-prong, grounding-type receptacle. Do not use this pump with a 2-prong wall outlet. Replace the 2-prong outlet with a properly grounded 3-prong receptacle (a GFCI outlet) installed in accordance with the National Electrical Code and local codes and ordinances. All wiring should be performed by a qualified electrician.
10. Protect the electrical cord from sharp objects, hot surfaces, oil, and chemicals. Avoid kinking the cord. Do not use damaged or worn cords.
11. Failure to comply with the instruction and designed operation of this unit may void the warranty. ATTEMPTING TO USE A DAMAGED PUMP can result in property damage, serious personal injury, and/or death.
12. Ensure that the electrical circuit to the pump is protected by a 5-amp minimum (15-amp max.) fuse or circuit breaker.
13. Do not lift the pump by the power cord.
14. Know the pump and its applications, limitations, and potential hazards.
15. Periodically inspect the pump and system components to ensure the pump suction screen is free of mud, sand, and debris. Disconnect the pump from the power supply before inspecting.
16. Follow all local electrical and safety codes, along with the National Electrical Code (NEC). In addition, all Occupational Safety and Health Administration (OSHA) guidelines must be followed.
17. The motor of this pump has a thermal protector that will trip if the motor becomes too hot. The protector will reset itself once the motor cools down and an acceptable temperature has been reached. The pump may start unexpectedly if it is plugged in.
18. Ensure the electrical power source is adequate for the requirements of the pump.
19. Before using the pump, check the hose for holes or excess wear, which could cause leaks, and ensure the hose is not kinked or making sharp angles. A straight hose allows the pump to move the greatest amount of water quickly, and also check that all hose connections are tight to minimize leaks.
20. This pump is made of high-strength, corrosion-resistant materials. It will provide trouble-free service for a long time when properly installed, maintained, and used. However, inadequate electrical power to the pump, dirt, or debris may cause the pump to fail. Please carefully read the manual and follow the instructions regarding common pump problems and remedies.

RESIDENTIAL USERS: Vendor assumes no liability for parts or labor coverage for component failure or other damages resulting from installation in non-commercial or residential applications. The right is reserved to deny shipment for residential usage; if this occurs, you will be notified as soon as possible.

1 YEAR PARTS AND LABOUR BENCH WARRANTY

Safety and Warranty

Within the warranty period, contact Omcan Inc. at 1-800-465-0234 to schedule a drop off to either an Omcan authorized service depot in the area, or to an Omcan Service warehouse to repair the equipment.

Unauthorized maintenance will void the warranty. Warranty covers electrical and part failures, not improper use.

Please see <https://omcan.com/disclaimer> for complete info.

WARNING:

The packaging components are classified as normal solid urban waste and can therefore be disposed of without difficulty.

In any case, for suitable recycling, we suggest disposing of the products separately (differentiated waste) according to the current norms.

DO NOT DISCARD ANY PACKAGING MATERIALS IN THE ENVIRONMENT!



Technical Specifications

Item Number	46788
Center Faucet Dimensions	4" / 102mm
Gooseneck Spout Dimensions	4" / 102mm
Water Tank Capacity	18.9 L / 5 Gal (x2)
Waste Tank Capacity	28.4 L / 7.5 Gal (x2)
Hose Length	37" / 940mm
Water Heater Tank Capacity	7.6 L / 2 Gal
Casters	5" / 127mm (2 with brakes)
Drain Basket Dimensions	1.5" / 38mm
Bowl Material	16 Gauge 304 Stainless Steel
Body Material	18 Gauge 430 Stainless Steel
Paper Towel Dispenser Material	Stainless Steel
Hand Soap Dispenser Material	18 Gauge 304 Stainless Steel
Electrical	110-120V / 60Hz / 1
Weight	69.5 lbs. / 31.5 kgs.
Packaging Weight	75 lbs. / 34 kgs.
Fabricated Bowl Dimensions	12" x 14" x 6" / 305 x 356 x 152mm
Dimensions	25.3" x 34.4" x 38.3" / 641 x 873 x 972mm
Packaging Dimensions	26.8" x 35.4" x 48.8" / 679 x 899 x 1238mm

Installation

The pump must be installed in a stationary position with either:

- A fixed pipeline.
- A flexible hose.

PLEASE NOTE!

1. Do not allow the pump to hang suspended by the power cord, inlet pipe or hose. The pump must be set on a stable surface or suspended from the handle. To ensure that the pump works properly, keep the intake area free from sludge and dirt of all kinds.
2. If the water level sinks too low, any sludge in the intake area will dry out and stop the pump from starting.

Installation

To help ensure the pump will start as required, check the pump regularly with start-up tests.

POWER SUPPLY

1. The pump is equipped with a shock-proof plug according to regulations. The pump is designed to be connected to 120 VAC, 60 Hz GFCI protected socket.
2. Make sure that the socket is sufficiently secured and is in excellent condition.
3. **WARNING:** To prevent death from electric shock, pump must be connected only to a GFCI protected outlet. **WARNING!** If the power cord or plug is damaged, do not use the pump. The power cord or plug may only be repaired by a certified electrician.

AREAS OF USE

- This pump is designed to pump water only.
- This pump is designed to be used for: General purpose removal or transfer of clear water.
- This pump should NOT be used for: Continuous run, fountain/pond water features. Removing water from swimming pools or spas. Septic or sewage systems.
- This pump can also be used to transfer water (e.g. household, farming, plumbing).

INSTALLATION INSTRUCTIONS

1. Attach hose to Pump intake port. Attach second hose to Pump discharge port.
2. Position Pump on solid surface so that both hoses are free from kinks.
3. Place unused end of intake hose in water to be transferred. Place unused end of discharge hose as needed to direct the water discharge at least 3 feet away from the source.

INSTALLING THE WATER HEATER

MOUNTING-DRYWALL (HOLLOW WALL)

1. The selected wall or cabinet must be capable of supporting double the weight of the unit when completely full of water (77 lbs).
2. The installation area must provide adequate clearances for removal of the front panel and servicing the unit.
3. Locate the wall studs in the area where the unit is to be mounted.
4. Cut two sections of 1/2 inch plywood or equivalent material 3 inches in height. The length of each section should be sufficient to span the width of the wall studs.
5. Use appropriately sized nails or wood screws to attach the two wall supports to the wall.
6. Drill two 13/32 inch holes in the upper wall support.

NOTE: The holes must be level.

7. Insert the hollow wall anchors into the drilled holes. Place the wall bracket over the anchors and screw the two Phillips head screws down tight against the bracket.

MOUNTING-MASONRY WALL (SOLID WALL)

1. The selected wall or cabinet must be capable of supporting double the weight of the unit when completely



Installation

full of water (77 lbs).

2. The installation area must provide adequate clearances for removal of the front panel and servicing the unit.
3. Drill two 13/32 inch holes in the masonry wall.
NOTE: The holes must be level and at least 3-1/2 inches deep.
4. Insert the masonry wall anchors into the drilled holes. Place the wall bracket over the anchors and screw the two Phillips head screws tight against the bracket.

WATER PIPING

HOT WATER CAN SCALD

Water heaters are intended to produce hot water. Water heated to a temperature which will satisfy space heating, clothes washing, dish washing, cleaning and other sanitizing needs can scald and permanently Injury you upon contact. Some people are more likely to be permanently injured by hot water than others. These include the elderly, children, the infirm, or physically/mentally disabled. If anyone using hot water in your home fits into one of these groups or if there is a local code or state law requiring certain temperature water at the hot water tap, then you must take special precautions. In addition to using the lowest possible temperature setting that satisfies your hot water needs, a means such as a mixing valve should be used at the hot water taps used by these people or at the water heater. Valves for reducing point of use temperature by mixing cold and hot water are also available.

Consult a Qualified Installer or Service Agency. Follow manufacturer's instructions for Installation of the valves. Before changing the factory setting on the thermostat, read the "Temperature Regulation" section in this manual.

This water heater shall not be connected to any heating systems or components used with a non potable water heating appliance.

Toxic chemicals, such as those used for boiler treatment shall not be introduced into this system.

Water supply system may, because of such events as high line pressure, frequent cut-offs, the effects of water hammer among others, have installed devices such as pressure reducing valves, check valves, back flow preventers, etc. to control these types of problems. When these devices are not equipped with an Internal by-pass, and no other measures are taken, the devices cause the water system to be closed. As water is heated, It expands(thermal expansion) and closed systems do not allow for the expansion of heated water.

The water within the water heater tank expands as it is heated and Increases the pressure of the water system. If the relieving point of the water heater's temperature-pressure relief valve is reached, the valve will relieve the excess pressure. The temperature-pressure relief valve is not limited for the constant relief of thermal expansion. This is an unacceptable condition and must be corrected.

It is recommended that any devices installed which could create a closed system have a by-pass and/or the system have an expansion tank or device to relieve the pressure built by thermal expansion in the water system. Expansion tanks are available for ordering through a local plumbing contractor. Contact the local water supplier and/or a service agency for assistance In controlling these situations.

Installation

NOTE: To protect against untimely corrosion of hot and cold water fittings, it is strongly recommended that the electric unions or couplings be installed on this water heater when connected to copper pipe.

The water heater is equipped with 1/2 inch NPT water connections.

If using copper tubing, older tubing to an adapter before attaching the adapter to the cold water inlet connection. Do not solder that cold water supply line directly to the cold water inlet, it will harm the dip tube and damage the tank.

WATER PIPING PRESSURE TEST

This section is only for the manufacturer installing the water heater when the installation is to comply with H.U.D. Standards. When testing the waterways, H.U.D. Standards state: "Water distribution system: All water piping in the water distribution system shall be subjected to a pressure test. The test shall be made by subjecting the system to air or water at 100 psi for 15 minutes without loss of pressure. When air pressure is used, the water heater shall not be connected during the test."

TEMPERATURE-PRESSURE RELIEF VALVE

This heater is provided with a properly certified combination temperature-pressure relief valve by the manufacturer.

The valve is certified by a nationally recognized testing laboratory that maintains periodic inspection of production of listed equipment of materials as meeting the requirements for Relief Valve for Hot Water Supply Systems, ANSI Z21.22 • CSA4.4, and the code requirements of ASME.

If replaced, the valve must meet the requirements of local codes, but not less than a combination temperature and pressure relief valve certified as indicated in the above paragraph.

The valve must be marked with a maximum set pressure not to exceed the marked hydrostatic working pressure of the water heater (150psi=1035kPa) and a discharge capacity not less than the water heater input rate as shown in the model rating plate.

For safe operation of the water heater, the relief valve must not be removed from its designated opening nor plugged.

The temperature-pressure relief valve must be installed directly into the fitting of the water heater designed for the relief valve. Provide tubing so that any discharge will exit only within 6 inches (153mm) above an adequate drain, or external to the building or structure. Be certain that no contact is made with any live electrical part. The discharge opening must not be blocked or reduced in size under any circumstances. Excessive length, over 30 feet (9.14m), or use of more than four elbows can cause restriction and reduce the discharge capacity of the valve.

No valve or other obstruction is to be placed between the relief valve and the tank. Do not connect tubing directly to discharge drain unless a 6 inch air gap is provided. The relief valve must be allowed to discharge

Installation

water in sufficient quantities, should circumstances demand, to prevent bodily injury, hazard to life, or property damage. If the discharge pipe is not connected to a drain or other suitable means, the water flow may cause property damage.

THE DISCHARGE PIPE:

- Shall not be smaller in size than the outlet pipe size of the valve, or have any reducing couplings or other restrictions.
- Shall not be plugged or blocked.
- Shall be of material listed for hot water distribution.
- Shall be installed so as to allow complete drainage of both the temperature-pressure relief valve, and the discharge pipe.
- Shall terminate at an adequate drain or external to the building or structure.
- Shall not have any shut-off valve between the relief valve and tank nor in the discharge pipe.

The temperature-pressure relief valve must be manually operated at least once a year. Caution should be taken to ensure that no one is in front of or around the outlet of the temperature-pressure relief valve discharge line, and the water manually discharged will not cause any bodily injury or property damage because the water may be extremely hot.

If after manually operating the valve, it fails to completely reset and continues to release water, immediately close the cold water inlet to the water heater, follow the draining instructions, and replace the temperature-pressure relief valve with a new one.

FILLING THE WATER HEATER

Never use this water heater unless it is completely full of water. To prevent damage to the tank and heating element, the tank must be filled with water. Water must flow from the hot water faucet before turning “ON” electrical supply to the water heater. The manufacturer will not warrant any elements damaged by failure to follow instructions.

TO FILL THE WATER HEATER WITH WATER:

1. Open the cold water supply valve to the water heater. The cold water supply valve must be left open when the water heater is in use.
2. To ensure complete filling of the tank, allow air to exit by opening the nearest hot water faucet. Allow water to run until a constant flow is obtained. This will let air out of the water heater and the piping.
3. Check all water piping and connections for leaks. Repair as needed.
4. Never alter or modify the certified construction of the water heater or its components, or bypass any safety features. Doing so voids all warranties.

WIRING

Never use the water heater unless it is completely full of water. To prevent damage to the tank and the heating element, the tank must be filled with water. Water must flow from the hot water faucet before turning on the power.

Installation

You must provide all wiring of the proper size outside of the water heater. You must obey the local codes and the electric company requirements when you install this wiring.

This water heater is supplied with a flexible, grounded power cord and connects to a standard three-wire 120 volt 60Hz, grounded type outlet. If an outlet is not within reach of the power cord, contact a local electrician/ electrical contractor or the local electric utility to have a properly sized circuit (including outlet, wiring and breaker) installed.

NOTE: Check the water heater's data plate for power requirements.

If you are not familiar with the electric codes and practices, or if you have any doubt, even the slightest doubt, in your ability to connect the wiring to the water heater, obtain the service of a competent electrician. Contact a local electrical contractor and/or the local electric utility.

WATER HEATERS EQUIPPED FOR ONE VOLTAGE ONLY:

This water heater is equipped for one type voltage only. Check the rating plate near the bottom access panel for the correct voltage. **DO NOT** use this water heater with any voltage other than the one shown on the models rating plate. Failure to use the correct voltage can cause problems which can result in **DEATH, SERIOUS BODILY INJURY, OR PROPERTY DAMAGE**. If you have any questions or doubts consult your electric company.

If wiring from your fuse box or circuit breaker box was aluminum for your old water heater, replace it with copper wire. If you wish to reuse the existing aluminum wire, have the connection at the water heater made by a competent electrician. Contact a local electrical contractor and /or the local electric utility.

Operation

After reading these instructions, consider the following points before starting the pump:

1. Verify that the discharge pipe is properly connected.
2. Verify that the electrical connection is 120 VAC, 60 Hz.
3. Verify that the electrical socket is GFCI protected and in good condition. Test GFCI protected outlet before use.
4. Verify that water and moisture cannot get near the power supply socket.
5. Verify that the pump is installed so as to prevent running dry.
6. Once plugged in, the pump will continue pumping until it is unplugged.

TEMPERATURE REGULATION

HOTTER WATER CAN SCALD:

Water heaters are intended to produce hot water. Water heated to a temperature which will satisfy space heating, clothes washing, dish washing, cleaning and other sanitizing needs can scald and permanently injury you upon contact. Some people are more likely to be permanently injured by hot water than others. These

Operation

include the elderly, children, the infirm, or physically/mentally disabled. If anyone using hot water in your home fits into one of these groups or if there is a local code or state law requiring certain temperature water at the hot water tap, then you must take special precautions. In addition to using the lowest possible temperature setting that satisfies your hot water needs, a means such as a mixing valve should be used at the hot water taps used by these people or at the water heater. Mixing valves are available from your local plumbing contractor. Follow manufacturer's instructions for installation of the valves.

Never allow small children to use a hot water tap or to draw their own bath water. Never leave a child or handicapped person unattended in a bathtub or shower.

It is recommended that lower water temperatures be used to avoid the risk of scalding. It is further recommended, in all cases, that the water temperature thermostat be set for the lowest temperature which satisfies your hot water needs. This will also provide the most energy efficient operation of the water heater. **KEEPING THE THERMOSTAT SETTING AT 120°F (49°C) OR LOWER WILL REDUCE THE RISK OF SCALDS.**

TO CHANGE THE TEMPERATURE SETTING:

The white knob on the front of the water heater is the temperature control. When the "OFF" mark is aligned with the raised indicator arrow, the water heater is off. Turn the knob clockwise to increase the temperature, and counterclockwise to decrease the temperature. The knob is marked with circular indentations of increasing size. The larger the indentation, the higher the temperature setting. The temperature range of this water heater is 68°F at the lowest setting and 158°F at the maximum setting. This water heater is shipped in the "OFF" position. Adjust the dial to the desired temperature.

FOR YOUR INFORMATION

THERMAL EXPANSION

Water supply systems may, because of such events as high line pressure, frequent cut-offs, the effects of water hammer among others, have installed devices such as pressure reducing valves, check valves, back flow preventers, etc. to control these types of problems. When these devices are not equipped with an internal by-pass, and no other measures are taken, the devices cause the water system to be closed. As water is heated, it expands (thermal expansion) and closed systems do not allow for the expansion of heated water.

The water within the water heater tank expands as it is heated and increases the pressure of the water system. If the relieving point of the water heater's temperature-pressure relief valve is reached, the valve will relieve the excess pressure. The temperature-pressure relief valve is not intended for the constant relief of thermal expansion. This is an unacceptable condition and must be corrected. It is recommended that any devices installed which could create a closed system have a by pass and/or the system have an expansion in the water system. Expansion tanks are available for ordering through a local plumbing contractor. Contact the local water heater supplier or service agency for assistance in controlling these situations.

STRANGE SOUNDS

Possible noises due to expansion and contraction of some metal parts during periods of heat-up and cool-down do not necessarily represent harmful or dangerous conditions.

Operation

OPERATION CONDITIONS

WATER ODOR

In each water heater there is installed at least one anode rod(see parts section) for corrosion protection of the tank. Certain water conditions will cause a reaction between this rod and the water. The most common complaint associated with the anode rod is one of a “rotten egg smell” in the hot water. This odor is derived from hydrogen sulfide gas dissolved in the water. The smell is the result of four factors which must all be present for the odor to develop:

- A concentration of sulfate in the supply water.
 - Little or no dissolved oxygen in the water.
 - A sulfate reducing bacteria which has accumulated within the water heater(this harmless bacteria is nontoxic to humans).
 - An excess of active hydrogen in the tank. This is caused by the corrosion protective action of the anode.
- Smelly water may be eliminated or reduces in some water heater models by replacing the anode(s) with one of less active material, and then chlorinating the water heater tank and all hot water lines. Contact the local water heater supplier or service agency for further information concerning an Anode Replacement and chlorination treatment; we can only suggest that chlorination or aeration of the water supply be considered to eliminate the water problem. Do not remove the anode leaving the tank unprotected. By doing so, all warranty on the water heater tank is voided.

AIR IN HOT WATER FAUCETS

HYDROGEN GAS:

Hydrogen gas can be produced in a hot water system that has not been used for a long period of time (generally two weeks or more). Hydrogen gas is extremely flammable and explosive. To prevent the possibility of injury under these conditions, we recommend the hot water faucet, located farthest away be opened for several minutes before any electrical appliances which are connected to the hot water system are used (such as a dishwasher or washing machine). If hydrogen gas is present, there will probably be an unusual sound similar to air escaping through the pipe as the hot water faucet at the time it is open.

HIGHER WATER TEMPERATURE SHUT OFF SYSTEM

A non-adjustable high temperature limit control operates before steam temperatures are reached. The high limit switch must be reset manually when it operates. BECAUSE THE HIGH LIMIT OPERATES ONLY WHEN ABNORMALLY HIGH WATER TEMPERATURES ARE PRESENT, IT IS IMPORTANT THAT A QUALIFIED SERVICE AGENT BE CONTACTED TO DETERMINE THE REASON FOR OPERATION BEFORE RESETTING.

- Turn off and unplug the water heater. Do not attempt to reset thermostat with power on.
- Remove the front panel, see “Removing Front Panel” in the Periodic Maintenance section.
- Removing the insulation to expose the reset button.
- Reset the high limit by pushing in the red button.
- Replace the insulation so that it completely covers the thermostat and element.
- Replace the front panel.
- Plug in and turn on the water heater.

CARE AND CLEANING

DO NOT

- Do not disassemble the motor housing. This motor has NO repairable internal parts, and disassembly may cause leakage or dangerous electrical wiring issues.

Do not lift up the pump by the power cord.

IF THE PUMP IS NOT RUNNING PROPERLY

- Remove the impeller cover screws.
- Remove the impeller cover.
- Inspect the gasket and impeller. If the impeller wears out, replace the impeller. The brushes could run 200 hours. If the brushes have been worn off, replace the brush. The brush must enter the square hole. Match the brush curve to the armature curve.

NOTE: Do not disassemble the motor housing of the pump. This motor has NO repairable internal parts, and disassembling may cause a dangerous electrical wiring issue.

ANODE ROD INSPECTION

The anode rod is used to protect the tank from corrosion. Most hot water tanks are equipped with an anode rod. The submerged rod sacrifices itself to protect the tank. Instead of corroding the tank, water ions attack and eat away the anode rod. This does not affect the water's taste or color. The rod must be maintained to keep the tank in operating condition.

NOTE: Artificially softened water is more corrosive because the process substitutes sodium ions for magnesium and calcium ions. The use of a water softener may decrease the life of the water heater tank.

Anode deterioration depends on water conductivity, not necessarily water condition. A corroded or pitted anode rod indicates high water conductivity and should be checked and/or replaced more often than an anode rod can extend the life of your water heater. Inspection should be conducted by a qualified technician, and at a minimum should be checked every three years. The anode rod in this unit is attached to the element flange. For removal instructions, see "ELEMENT CLEANING/REPLACEMENT."

Typical (but not all) signs of a depleted anode rod are as follows:

1. The majority of the rods diameter is less than 3/8".
 2. Significant sections of the support wire (approximately 1/3 or more if the anode rod's length) are visible.
- If the anode rod shows signs of either or both it should be replaced.

NOTE: Whether re-installing or replacing the anode rod, check for any leaks and immediately correct if found.

TEMPERATURE-PRESSURE RELIEF VALVE OPERATION

The temperature-pressure relief valve must be manually operated at least once a year. When checking the

Maintenance

temperature-pressure relief valve operation, make sure that no one is in front of or around the outlet of the temperature-pressure relief valve discharge line, and that the water discharge will not cause any property damage, as the water may be extremely hot.

If after manually operating the valve, it fails to completely reset and continues to release water, immediately close the cold water inlet to the water heater, follow the draining instructions, and replace the temperature-pressure relief valve with a new one.

If the temperature-pressure relief valve on the appliance weeps or discharges periodically, this may be due to thermal expansion. You may have a check valve installed in the water line or a water meter with a check valve. Consult your local water supplier or service agency for further information. Do not plug or remove the temperature-pressure relief valve.

DRAINING

The water heater should be drained if being shut down during freezing temperatures. Also periodic draining and cleaning of sediment from the tank may be necessary.

1. Turn off and unplug the water heater from the electric outlet.
2. CLOSE the cold water inlet valve to the water heater.
3. OPEN a nearby hot water faucet and leave open to allow for draining.
4. Disconnect water connections. Remove unit from wall. UNIT WILL BE HEAVY. Turn unit upside down and drain unit into a suitable drain or receptacle.

REMOVING THE FRONT PANEL

1. Turn off and unplug the water heater from the electric outlet and follow "DRAINING INSTRUCTIONS".
2. Remove the temperature knob by pulling straight out.
3. Using a Philips screwdriver, unscrew the bottom screw securing the outer door.
4. Lift up and remove front panel.

THERMOSTAT REMOVAL/REPLACEMENT

REMOVAL

1. Turn off and unplug the water heater from the electric outlet.
2. Remove the front panel; see the "REMOVING THE FRONT PANEL" section in this manual. Remove the insulation pad.
3. Using a 7mm wrench, loosen the nuts securing the high limit switch to the tank enough to rotate the switch 90° counterclockwise and slide it out from beneath the bracket. It is not necessary to remove the nuts completely.
4. Remove the 3 wires (white, brown, and green/yellow) from the thermostat at the spade connections, carefully taking note of the original location of each wire.
5. Unscrew the 2 screws securing the thermostat to the front panel and remove thermostat.

REPLACEMENT

1. Place the new thermostat against the front panel and secure it with the two screws.

2. Reattach the wires at the spade connections, taking care to place them in their original locations. Be sure to push the connector completely onto the spade terminals.
3. Secure the temperature sensor to the tank by tightening the nuts. Be sure the sensor is firmly in contact with the tank surface.
4. Replace the insulation block and the front panel.

ELEMENT CLEANING/REPLACEMENT

To remove the element from the tank in order to clean or replace it:

1. Turn off and unplug the water heater from the electrical outlet and follow "DRAINING INSTRUCTIONS."
2. Remove the front panel; see the "REMOVING THE FRONT PANEL" section in this manual. Remove the insulation pad.
3. Remove the two screws from the mounting bracket, being careful not to drop the screws into the unit, as they will be difficult to retrieve. Remove bracket and set screws aside.
4. Remove the two spade connectors from the element.
5. Using a 10mm wrench, remove the four nuts around the element flange. Set nuts and lock washers aside.
6. Lift element up to clear the four mounting bolts, rotate 15° clockwise, and lift out.
7. Discard the old gasket and clean the area around the element opening. Removing any sediment from or around the element opening and inside the tank.
8. If you are cleaning the element you have removed, do so by scraping or soaking in vinegar or a de-liming solution.

NOTE: Replacement elements must be the same voltage and no greater wattage than listed on the model rating plate affixed to the water heater.

9. A new gasket must be used in all cases to prevent a possible water leak. Place new element gasket in the element opening over the four element bolts, orienting the gasket bulge facing waterside.
10. Insert the curved part of the element, rotate 20° clockwise, and continue to insert the element, being sure that the four bolts fit into the element flange.
11. Replace the four lockwashers and 10mm nuts. Tighten until snug.
12. Place unit back on wall mounting bracket hooks. Reconnect the water inlet and outlet, open the nearest hot water tap and follow filling instructions.
13. Never use this water heater unless it is completely full of water. To prevent damage to the tank and heating element, the tank must be filled with water. Water must flow from the hot water faucet before turning "ON" power. The manufacturer will not warranty any elements damaged by failure to follow instructions.
14. Check element for water leaks. If leakage occurs, tighten element. If necessary drain tank before repeating Step 7 and 8, remove element and reposition gasket. Then repeat Step 10 through 14.
15. Replace the two spade connectors on element into their original positions.
16. Replace the mounting bracket with the center rise facing outward and the screw hole up.
17. Replace the insulation and front panel, lining up the three tabs at the top with the slots in the casing.
18. Replace the retaining screw and the temperature knob.
19. Plug heater into electrical outlet.

TO REMOVE AND REPLACE ANODE:

1. Follow steps 1-8 of the Element Cleaning/Replacement section.
2. Using a 7mm wrench, remove the nut securing the anode.
3. Unscrew and remove anode.

Maintenance

4. Screw in the new anode and secure with the retaining nut.
5. Follow instructions for replacing the element in “ELEMENT CLEANING/REPLACEMENT.”

HIGH LIMIT SWITCH REMOVAL AND REPLACEMENT

1. Turn off and unplug the heater from the electrical outlet.
2. Remove the front panel; see the “REMOVING THE FRONT PANEL” section in this manual. Remove the insulation pad. Remove personnel barrier.
3. Remove the four wires connected to the switch, taking care to note the original placement of each wire.
4. Using a 7mm wrench, remove the nuts securing the high limit switch to the tank enough to rotate the switch 90° counterclockwise and slide it out from beneath the bracket. It is not necessary to remove the nuts completely.
5. Place the new switch beneath the bracket and rotate it 90° clockwise.
NOTE: The taller spade terminal will be on the right side.
6. Replace and tighten the nuts so the high limit switch is firmly in contact with the tank surface.
7. Replace the four wires, taking care that they are replaced into their original positions and tighten screws.
8. Replace personnel barrier; replace insulation block and the front panel.

SERVICE

If a condition persists or you are uncertain about the operation of the water heater contact a service agency.

Use this guide to check a “Leaking” water heater. Many suspected “Leakers” are not leaking tanks. Often the source of the water can be found and corrected.

If you are not thoroughly familiar with your water heater and safety practices, contact a qualified installer to check the water heater.

LEAKAGE CHECKPOINTS

Read this manual first. Make sure the electrical power supply has been turned “OFF” before checking the tank for leakage.

- Condensation and dripping may be seen on pipes if the water temperature is low in humid weather or pipe connections may be leaking.
- Small amounts of water from temperature-pressure relief valve may be due to thermal expansion or high water pressure in your area. If the valve is not piped to an open drain the released water could be mistaken for a leaking heater, see “Thermal Expansion” section.
- The temperature-pressure relief valve may be leaking at the tank fitting.
- Water on the side of the tank may be condensation due to the panel or insulation not being in place.
- Water in the water heater bottom or on the floor may be from condensation, loose connections, or the relief valve. DO NOT replace the water heater until a full inspection of all possible water sources is made and necessary corrective steps taken.

Leakage from other appliances, water lines, or ground seepage should also be checked.

Maintenance

- To check where threaded portion enters tank, insert cotton swab between jacket opening and fitting. If cotton is wet, follow “Draining” instructions in the “Periodic Maintenance” section and then remove fitting. Put pipe dope or Teflon tape on the threads and replace. Then follow “Filling the Water Heater” instructions in the “Installing the New Water Heater” section.

Troubleshooting

SYMPTOM	POSSIBLE CAUSE	CORRECTIVE ACTION
The pump does not start or run.	The fuse is blown.	Replace the fuse.
	The breaker is tripped.	Reset the breaker.
	The plug is disconnected.	Secure the plug.
	The plug is corroded.	Clean the plug prongs.
	The brushes are worn.	Replace the brushes.
	The motor is overheated.	Unplug the power and wait for 30 minutes, then plug in the power cord.
The pump does not prime.	The suction line is air leaked.	Repair suction line by tightening hose connection or replacing hose washer if necessary.
	The impeller is clogged.	Remove the blockage.
	The impeller is worn or damaged.	Replace the impeller.
	The impeller is dry.	Add water to the pump inlet.
The flow rate is too low.	The hose is kinked or coiled.	Straighten the hose.
	The strainer or hose is blocked.	Clean the strainer or hose.
	The discharge hose is too long.	Shorten the hose (50 ft. max).
	The impeller is worn.	Replace the impeller.
Water leaks.	Improperly sealed hot or cold supply connection, relief valve or drain valve.	Tighten threaded connections.
	Leakage from other appliances or water lines.	Inspect other appliances near heater.
No hot water.	No power to heater.	Turn on electrical switch. Check for blown fuses or tripped breakers.
	High temperature limit switch open.	Reset. Check for source of trouble and correct.
	Non-functioning thermostat.	Replace thermostat.

Troubleshooting

Insufficient hot water.	Non-functioning thermostat.	Replace thermostat
	Improper calibration.	Replace thermostat
	Thermostat set too low.	Set thermostat to desired temperature.
	Sediment or lime in tank.	Drain. Determine if water treatment is needed.
	Heater too small for job.	Install adequate water heater.
	Wrong piping connections.	Correct piping.
	Leaking faucets.	Repair faucets.
	Wasted hot water.	Review and reduce hot water consumption.
	Long runs of exposed pipe.	Insulate piping.
	Hot water piping on outside wall.	Insulate piping.
High operation costs	Improper Calibration.	Replace thermostat.
	Thermostat set too high.	Set thermostat to desired setting.
	Sediment or lime in tank.	Drain. Flush-Provide water treatment if needed.
	Heater too small for job.	Install adequate heater.
	Wrong piping connections.	Correct piping.
	Leaking faucets.	Repair faucets.
	Wasted hot water.	Review and reduce hot water consumption.
	Long runs of exposed piping.	Insulate piping.
	Hot water piping in exposed wall.	Insulate piping.
Slow hot water recovery.	Non-functioning element.	Replace element.
Drip from relief valve.	Excessive water pressure.	Use Pressure Reducing Valve and Pressure Relief Valve.
	Closed system.	See "Thermal Expansion" in the For Your Information section.
Thermostat does not shut off.	Non-functioning element.	Replace thermostat.
	Improper calibration.	Replace thermostat.
Water odor.	Sulfides in the water.	See "Operational Conditions" in the For Your Information section.
Water heater sounds.	Scale accumulation on elements.	Contact dealer to clean or replace elements.

For service call 1-800-465-0234.

Parts Breakdown

Item 46788

Pump

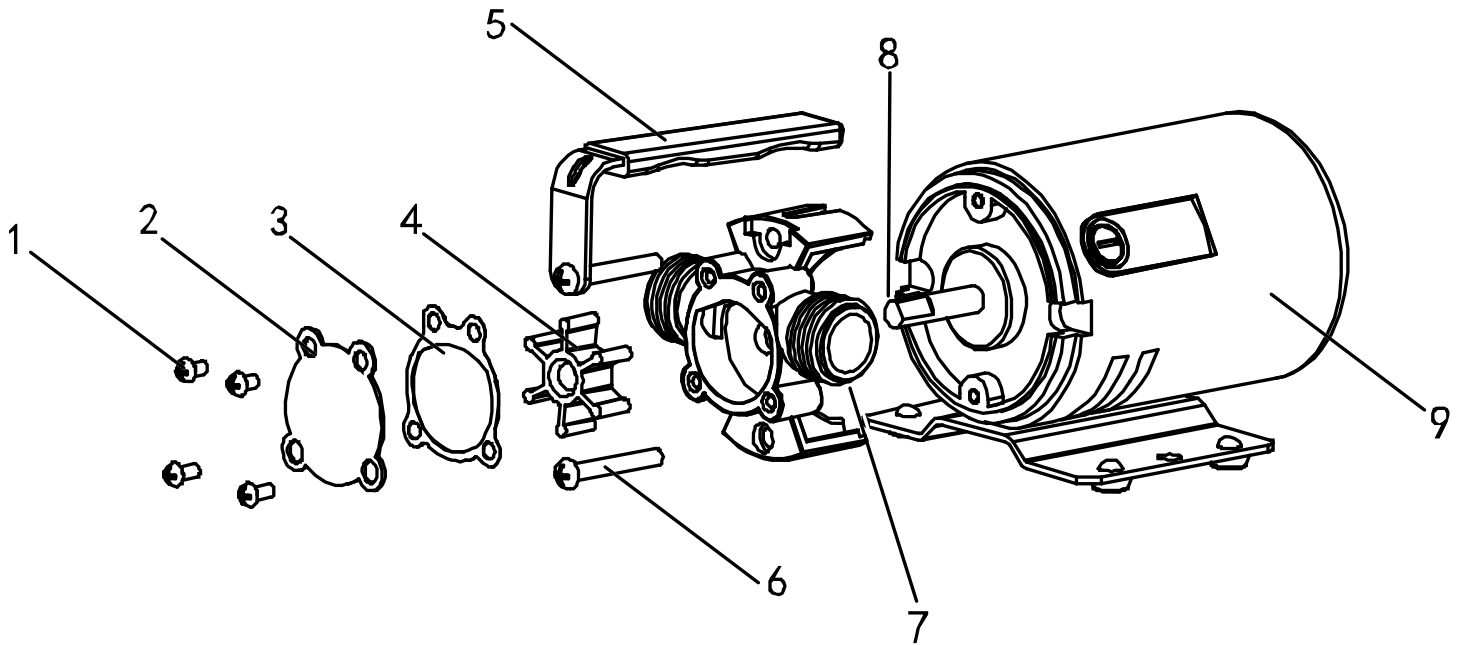

Parts Breakdown

Item 46788

Electric Water Heater

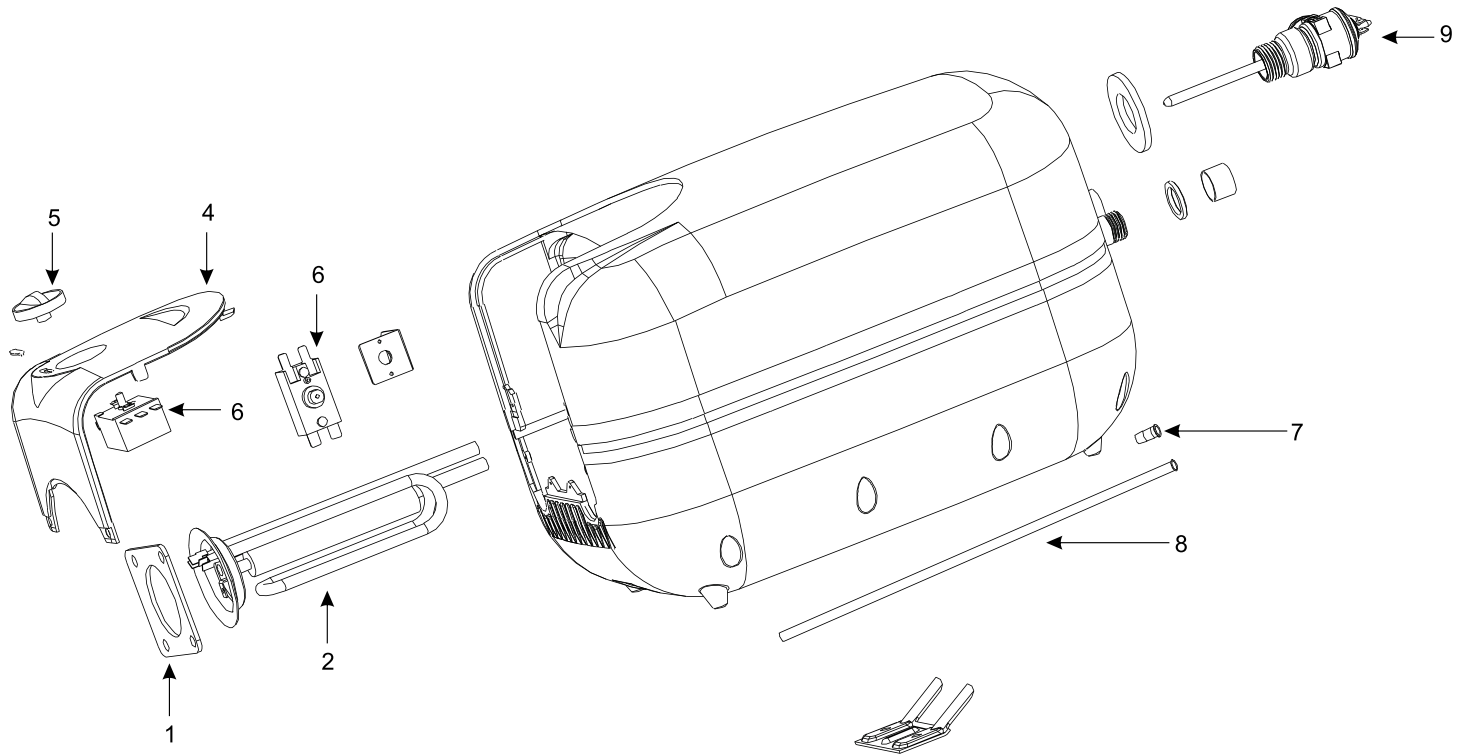

Parts Breakdown

Item 46788

Pump

Item No.	Description	Position	Item No.	Description	Position	Item No.	Description	Position
AK245	Screw of Pump for 46788	1	AK248	Impeller of Pump for 46788	4	AK251	Body of Pump for 46788	7
AK246	Impeller Cover of Pump for 46788	2	AK249	Handle of Pump for 46788	5	AK252	Shaft of Pump for 46788	8
AK247	Gasket of Pump for 46788	3	AK250	Screw of Pump for 46788	6	AK253	Motor of Pump for 46788	9

Electric Water Heater

Item No.	Description	Position	Item No.	Description	Position	Item No.	Description	Position
AK254	Fixed Plate of Water Heater for 46788	1	AK257	Decorative Cover of Water Heater for 46788	4	AK260	Rubber Sealing Ring of Water Heater for 46788	7
AK255	Heating Element of Water Heater for 46788	2	AK258	Knob of Water Heater for 46788	5	AK261	Inlet Pipe of Water Heater for 46788	8
AK256	Thermostat of Water Heater for 46788	3	AK259	Thermal Cut-Off of Water Heater for 46788	6	AK262	Valve of Water Heater for 46788	9

Electrical Schematics

Item 46788

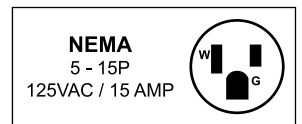
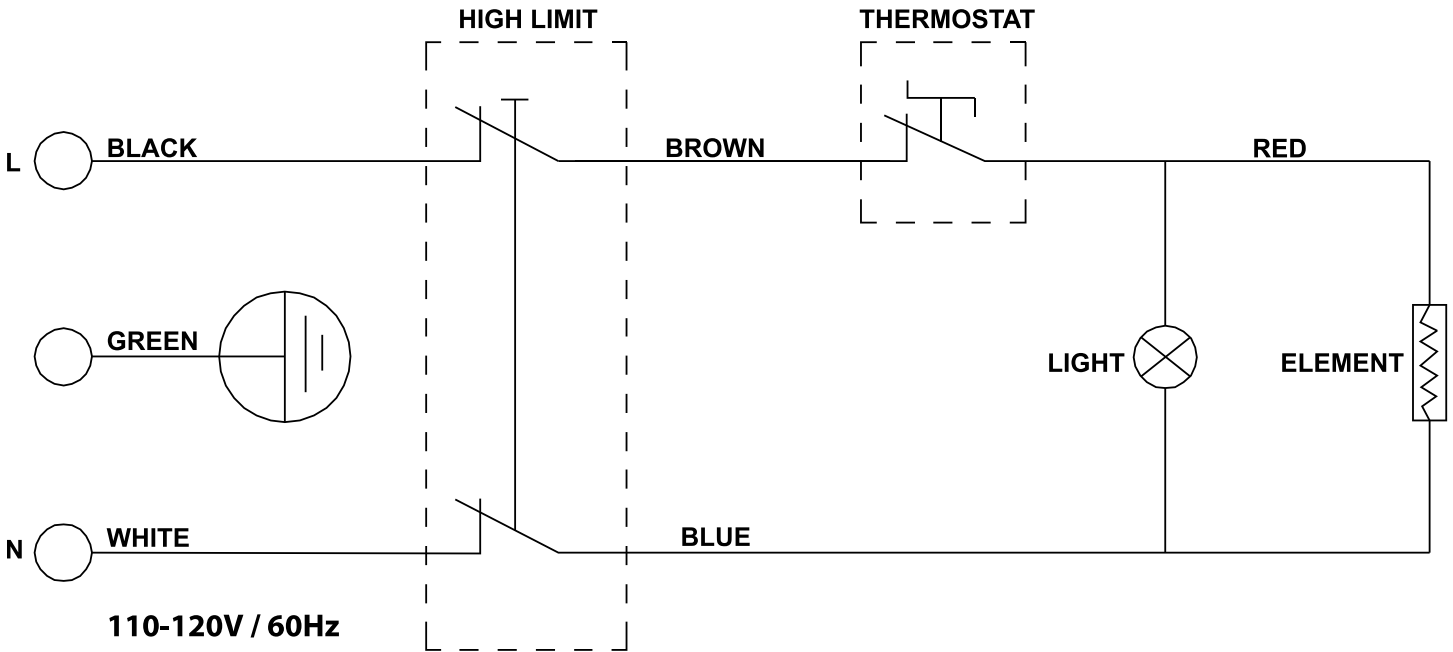



Notes



Warranty Registration

Thank you for purchasing an Omcan product. To register your warranty for this product, complete the information below, tear off the card at the perforation and then send to the address specified below. You can also register online by visiting:

Merci d'avoir acheté un produit Omcan. Pour enregistrer votre garantie pour ce produit, complétez les informations ci-dessous, détachez la carte au niveau de la perforation, puis l'envoyer à l'adresse spécifiée ci-dessous. Vous pouvez également vous inscrire en ligne en visitant:

Gracias por comprar un producto Omcan usted. Para registrar su garantía para este producto, complete la información a continuación, cortar la tarjeta en la perforación y luego enviarlo a la dirección indicada a continuación. También puede registrarse en línea en:

<https://omcan.com/warranty-registration/>

For mailing in Canada

Pour postale au Canada

Por correo en Canadá

OMCAN

PRODUCT WARRANTY REGISTRATION

3115 Pepper Mill Court,

Mississauga, Ontario

Canada, L5L 4X5

For mailing in the US

Pour diffusion aux États-Unis

Por correo en los EE.UU.

OMCAN

PRODUCT WARRANTY REGISTRATION

4450 Witmer Industrial Estates, Unit 4,

Niagara Falls, New York

USA, 14305

or email to: service@omcan.com



Purchaser's Information

Name: _____

Address: _____

City: _____ Province or State: _____ Postal or Zip: _____

Country: _____

Dealer from which Purchased: _____

Dealer City: _____ Dealer Province or State: _____

Invoice: _____

Model Name: _____ Model Number: _____

Machine Description: _____

Date of Purchase (MM/DD/YYYY): _____

Would you like to extend the warranty? Yes No

Company Name: _____

Telephone: _____

Email Address: _____

Type of Company:

Restaurant Bakery Deli

Butcher Supermarket Caterer

Institution (*specify*): _____

Other (*specify*): _____

Serial Number: _____

Date of Installation (MM/DD/YYYY): _____

Thank you for choosing Omcan | Merci d'avoir choisi Omcan | Gracias por elegir Omcan



Since 1951 Omcan has grown to become a leading distributor of equipment and supplies to the North American food service industry. Our success over these many years can be attributed to our commitment to strengthen and develop new and existing relationships with our valued customers and manufacturers. Today with partners in North America, Europe, Asia and South America, we continually work to improve and grow the company. We strive to offer customers exceptional value through our qualified local sales and service representatives who provide convenient access to over 6,500 globally sourced products.

Depuis 1951 Omcan a grandi pour devenir un des “leaders” de la distribution des équipements et matériel pour l’industrie des services alimentaires en Amérique du Nord. Notre succès au cours de ces nombreuses années peut être attribué à notre engagement à renforcer et à développer de nouvelles et existantes relations avec nos clients et les fabricants de valeur. Aujourd’hui avec des partenaires en Amérique du Nord, Europe, Asie et Amérique du Sud, nous travaillons continuellement à améliorer et développer l’entreprise. Nous nous efforçons d’offrir à nos clients une valeur exceptionnelle grâce à nos ventes locales qualifiées et des représentants de service qui offrent un accès facile à plus de 6500 produits provenant du monde entier.

Desde 1951 Omcan ha crecido hasta convertirse en un líder en la distribución de equipos y suministros de alimentos en América del Norte industria de servicios. Nuestro éxito en estos años se puede atribuir a nuestro compromiso de fortalecer y desarrollar nuevas relaciones existentes con nuestros valiosos clientes y fabricantes. Hoy con socios de América del Norte, Europa, Asia y América del Sur, que trabajan continuamente para mejorar y crecer la empresa. Nos esforzamos por ofrecer a nuestros clientes valor excepcional a través de nuestro local de ventas y representantes de los servicios que proporcionan un fácil acceso a más de 6,500 productos con origen a nivel mundial.

