

NOM-39-HT

GRAB 'N GO HEATED OPEN MERCHANDISERS

Ideal for restaurants, cafés, convenience stores and supermarkets



FEATURES



Pull-down night curtain



Warm-toned LED lighting on the top of unit and under each shelf

Temperature of each shelf is independently controlled



Price tag channels

Front bumper & handle to access control panel



Brushed stainless steel exterior

4 heavy duty casters and 2 front legs



ADDITIONAL FEATURES

- ✓ Control panel: separate digital temperature control and light switches in bottom drawer



SPECIFICATIONS

Capacity (Cubic Feet)	15.5
Capacity (Litres)	439 L
Exterior Unit Dimensions (in)	39.4" (w) x 30.4" (d) x 76.9" (h)
Interior Dimensions (in)	38" (w) x 21" (d) x 53" (h)
Net/Gross Weight (lb)	437 / 584
Night Curtain	Yes
Swivel Casters	4 casters
Front Support Legs	2
Front Bumper	Yes
Shelves	3 + base
Shelf Dimensions	36.92" (w) x 17.5" (d) / per shelf + base 36.92 (w) + 17.5 (d)
Shelf Capacity (lb)	80
Temperature	65-71°C
Input Power	1966.5 - 2300 W
Voltage	208-240V/60Hz/1p
Amperage	17.1 - 20
Plug Type	Not supplied - designed for Nema 6-30p

SIDE & INTERIOR VIEW

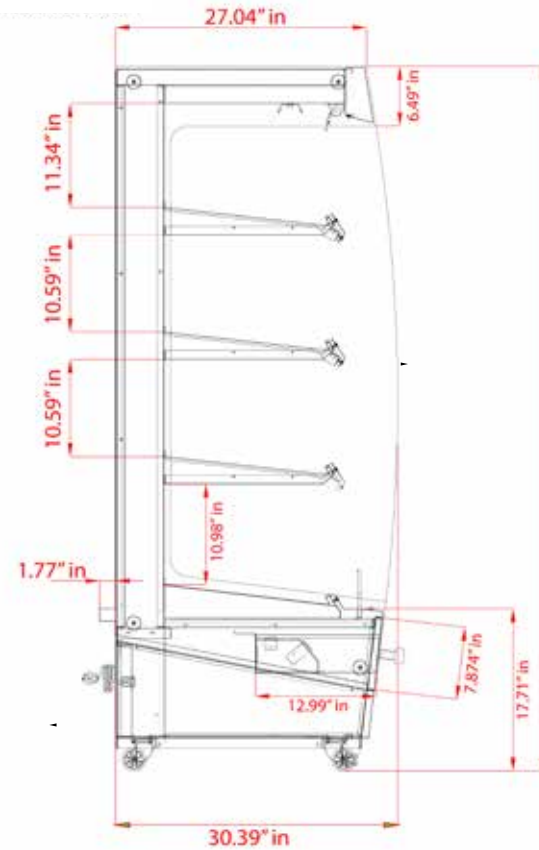

FRONT VIEW

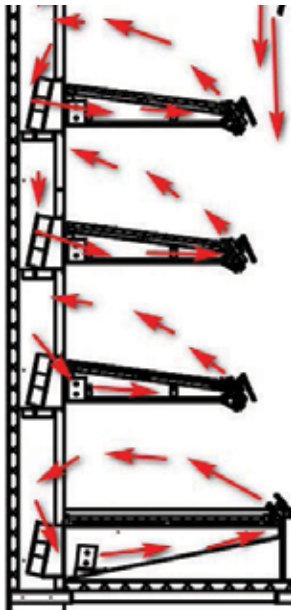
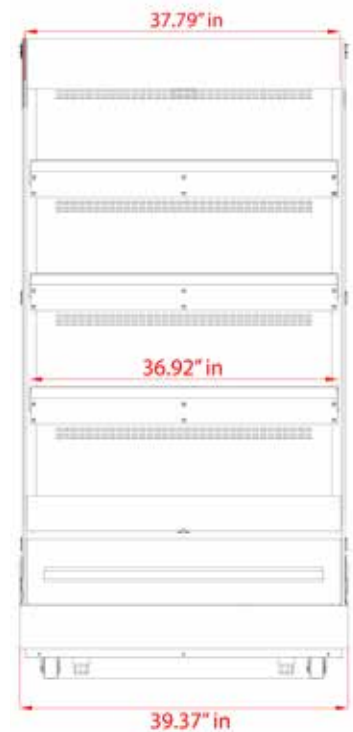

AIR CIRCULATION:
Hot air circulates around each shelf surface keeping products warm. These units are designed to hold pre-cooked foods at 65°C to 71°C (149°F to 160°F)



CUSTOMER SUPPORT



We're on social media!
1.800.567.3620



www.newairrefrigeration.ca

MORE PRODUCTS!



Design and specifications can change without prior notice for product improvement