



## Roll•A•Grill

Model Series: 8230, 8250, Electronic Rollergrills

### **INTRODUCTION**

1. Please read instructions before using.
2. This roller grill will be HOT during use and for a short time after it is turned off – BE CAREFUL!

### **INSTALLATION**

1. Set the roller grill on a flat surface.
2. Position the roller grill near the power outlet. Avoid the use of extension cords.
3. Plug the roller grill into a certified electrical outlet with a corresponding voltage rating as listed on the roller grill model label.
4. Clean the roller grill thoroughly before use.

### **OVERVIEW OF CONTROLS**

1. There is a lighted rocker switch to turn the roller grill on.
2. There are two zone buttons (front and rear) which are also used as up and down buttons during the settings mode.
3. There are a set of four indicator lights for each zone to indicate which phase of the cook cycle that zone is currently in (preheat, cook, hold – below 160°F, and hold – above 160°F)
4. There is also a display that shows either the time left before the product is ready to serve, or the temperature of the zone when the product is ready to serve.
5. There are two indicator lights by the zone buttons to show which zone the display is currently showing.

### **OPERATION**

1. Turn the switch on to turn the roller grill on. The lights will all flash when the controls power up and the rocker switch will then light up.
2. The display shows dashes to indicate that no heat cycle is active. At this point the product can be placed on the rollers and the appropriate zone button (front or rear) can be pressed to initiate the cook cycle for that zone. The front and rear of the grill are denoted by the two different colors of roller end seals; black for front, white for rear.
3. After pressing the zone button, the roller grill will begin a 10 minute preheat phase which is designed to be part of the cook cycle. It will then automatically adjust the temperature for the cook phase. Once the grill completes the cook phase, it will automatically adjust the temperature for the hold phase.
4. During the cook phase, the grill will display how much time is left before the product is ready (all times are in hours and minutes). Once the product is ready, the display changes to show the temperature of the product. At this point the product is ready to serve. Once the holding time has expired, the hold light will begin to flash to indicate that the food is beyond it's recommended holding time.  
Note: The roller grill will turn on the appropriate indicator light to indicate which phase it is in (preheat, cook hold).
5. When both zones are in operation, the display of the grill will cycle from the front zone to the rear zone to display the status of each. To see the status of a zone immediately, tap that zone's button and the display will change to show its status.
6. If product has been used up, and the hold cycle needs cancelled, press and hold the appropriate zone button (front or rear). The hold light will then turn off to indicate that the zone is no longer heating.
7. Also, the operator can skip the preheat cycle once it is initiated by pressing and holding the zone button (front or rear). The same can be done with the cook cycle.

## **CHANGING THE COOK CYCLE SETTINGS**

1. The front and rear zone cook settings can be set individually. To change the settings of one of these zones, make sure the grill is on and the heat zone is off. Press and hold the “Settings” button while pressing the appropriate zone button (front or rear) and release both when the cook lights begin flashing.
2. The cook light will begin to flash and the display will show the current cook heat setting. This is how much heat is applied to the rollers during the cook cycle and can be set to any number from 0.00 to 1.00. The settings can be adjusted up or down using the two zone buttons which have up and down arrows on them. To advance to the next setting, press the “Settings” button.
3. The next setting is the cook time (in hours and minutes).
4. After the cook settings are set, the hold lights begin to flash and the grill shows the hold heat setting.
5. The last setting is the hold time (again in hours and minutes).
6. After setting the hold settings, press the “Settings” button again to exit the settings mode.

## **CLEANING**

**NOTE:** Proper maintenance plays an important part in the life span and functioning of the roller grill

1. When the grill is off, press each zone button (front and rear) to begin heating the grill up.
2. Once the grill is hot, then the rollers can be wiped down.
3. **ALWAYS START AT THE END OF THE ROLLERS AND WIPE TOWARD THE CENTER.** This prevents extra grease from entering the sides of the roller grill and into the bearings.
  - ◆ GripsIt rollers: Use a wet, soft cloth to wipe the rollers clean. **NOTE:** never use any metal object on the GripsIt rollers at any time. Metal will cause serious damage to the rollers.
  - ◆ Silverstone rollers: Use a scratch proof sponge made for non-stick coated products or a soft cloth to wipe the rollers clean. If the build up on the rollers cannot be removed by just wiping with a wet sponge, wrap some ice cubes inside a soft towel and rub over the rollers. **NOTE:** never use any metal object on the Silverstone rollers at any time. Metal will cause serious damage to the rollers.
  - ◆ Chrome rollers: Each roller grill comes with a two sided sponge. Use the rough side of the sponge to remove all residue from the rollers. If build up of residue cannot be removed from the rollers by wiping with a course sponge you may use any type of kitchen abrasive to clean the rollers.
4. After cleaning the rollers, remove the drip pan and clean with mild soap and water.

## **SERVICE INSTRUCTIONS**

### **IF ROLLERS WON'T TURN**

1. Check power source to be sure the roller grill is plugged into the proper voltage outlet and that the outlet is in proper working order.
2. **IMPORTANT:** Disconnect the roller grill from the power source before disassembly.
3. Remove the end covers.
4. If the drive chain is off the idler sprocket, reinstall it.
5. Remove the drive chain from the sprocket on the motor shaft and if the rollers turn easily, then replace the motor.
6. Remove the chain guard and inspect the sprockets on the end of each roller. If they are loose, worn, or out of alignment, then replace the roller.
7. If the rollers are hard to turn by hand (without the chain attached) remove and clean out any accumulated foreign matter in the bearings and on the rollers.
8. **IMPORTANT:** Reassemble the roller grill completely before reconnecting to the power source.

### **IF ROLLER GRILL BLOWS A FUSE OR CIRCUIT BREAKER**

1. Check the capacity of the circuit being used to be sure it is not overloaded.
2. Unplug the roller grill and check it's wiring for short circuits.

### **IF ROLLERS WON'T HEAT**

Check the power source to be sure the roller grill is plugged into the proper voltage outlet and the receptacle is working. If properly connected and still no heat call NEMCO customer service at 1-800-782-6761.

***NOTE: WARRANTY DOES NOT COVER DAMAGE TO THE ROLLERS OR ROLLER COATING. IT IS NEMCO'S SOLE DISCRETION TO DETERMINE IF A ROLLER OR ROLLER COATING CLAIM IS WARRANTED.***

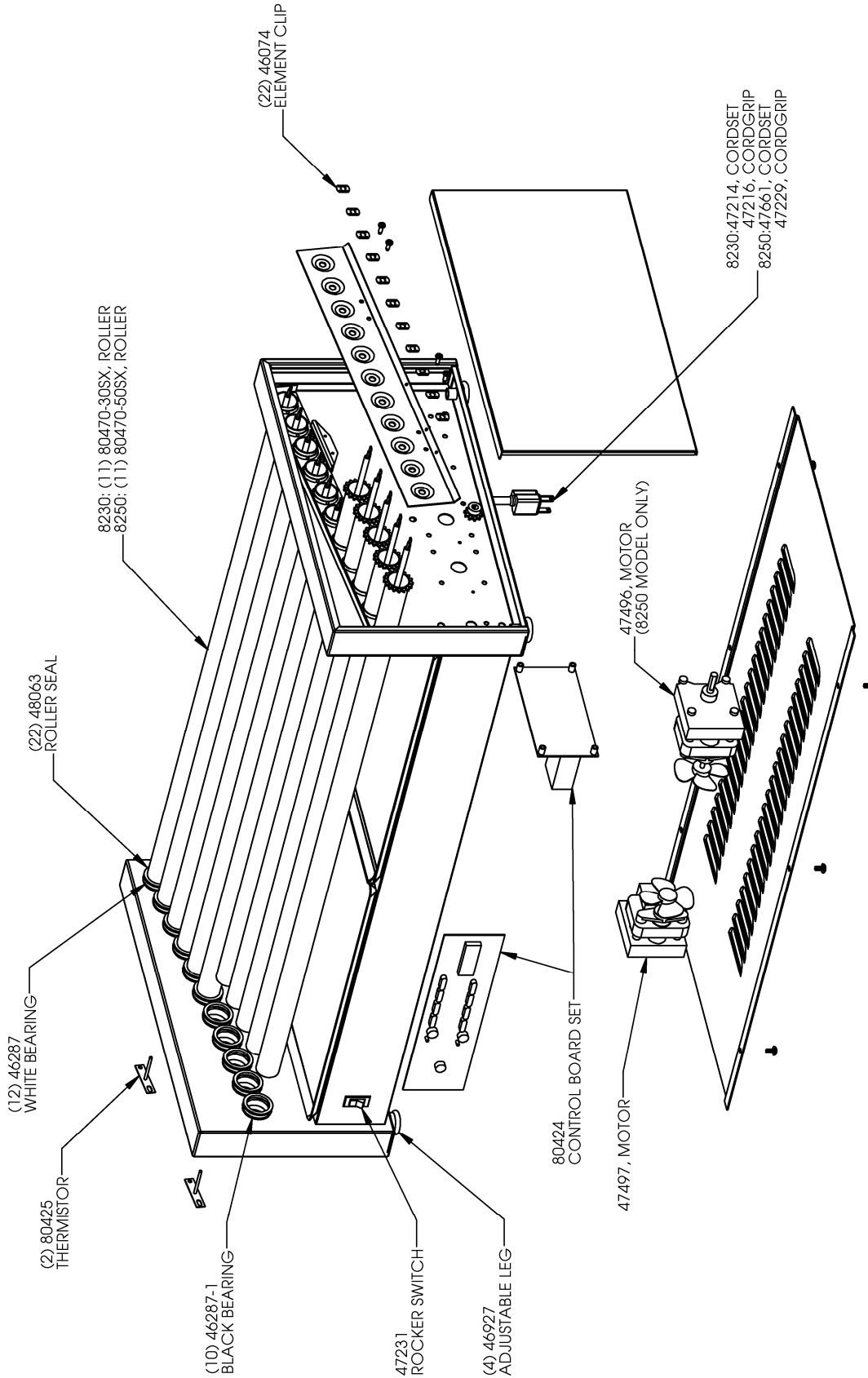

**NEMCO FOOD EQUIPMENT** 301 Meuse Argonne, Hicksville, OH 43526  
Phone: (419) 542-7751 Fax: (419) 542-6690 Toll free: 1-800-782-6761  
[www.nemcofoodequip.com](http://www.nemcofoodequip.com)



Intertek

IN82XX  
5-15-12