



Roller Grill with Digital Temperature Readout

model #: **8050SX-RC, 8050SX-SLT-RC,
8075SXW-RC, 8075SXW-SLT-RC**

Nemco's roller grills have always been famous for their superior diehard cooking performance. 360° roller rotation prevents residue buildup, while individual roller heating elements ensure heating consistency. Removable drip pan makes for easy cleaning. Requires no ventilation system. Infinite controls offer versatile temperature control. Front and rear rollers have their own heat controls. This feature permits shutting off one section during non-peak hours. Includes a digital readout that displays the approximate food temperature of the product for both zones. Easy access to the two motors and chain from side panels. *GripsIt*, Nemco's optimized non-slip technology, allows for turning of a variety of items, including breaded and sugary-coated products, all while keeping clean-up easy.

STANDARD FEATURES

- Rugged stainless steel construction
- Simplest installation - plugs into any outlet with corresponding voltage
- *GripsIt* rollers offer non-slip technology that cleans easily with just a damp sponge
- Easy to see color coded grease seals to identify front and rear rollers
- Rollers rotate at a complete 360° turn by means of a roller sprocket, motor sprocket and chain
- End bearing and grease barrier double protect against grease seepage
- Control cover
- 4" adjustable legs
- One year parts and labor warranty
- ETL, ETL CSA & NSF listed

Note: The chains that drive the rollers should be inspected and greased once a year to be sure that they continue to operate correctly. This will allow the machine to operate for a much longer time.



Roller Grill with Digital Temperature Readout

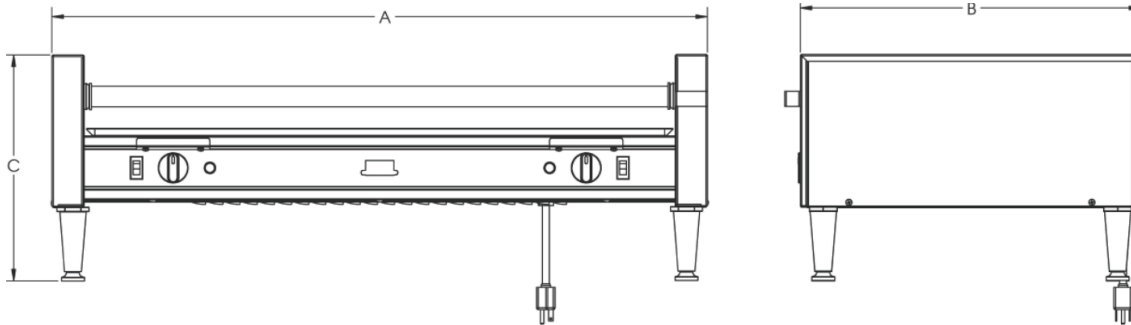

Model #	Description	Size	Volts	Watts	Amps	No. of Rollers	No. of Cords	No. of 5" Franks Per Hour	Unit Weight	Shipping Weight
8050SX-RC	50 Hot Dogs, Gripslt	35 $\frac{3}{4}$ " x 18 $\frac{1}{16}$ " x 12 $\frac{1}{4}$ "	120	1430	11.9	11	1 / 5-15P	50-1000	60 lbs	71 lbs
8050SX-SLT-RC	Slanted, 50 Hot Dogs, Gripslt	35 $\frac{3}{4}$ " x 18 $\frac{1}{16}$ " x 13 $\frac{3}{4}$ "								
8075SXW-RC	75 Hot Dogs, Gripslt	35 $\frac{3}{4}$ " x 26 $\frac{3}{16}$ " x 12 $\frac{1}{4}$ "	120	1920	16.0	16	1 / 5-20P	75-1500	80 lbs	93 lbs
8075SXW-SLT-RC	Slanted, 75 Hot Dogs, Gripslt	35 $\frac{3}{4}$ " x 26 $\frac{3}{16}$ " x 13 $\frac{3}{4}$ "								

TYPICAL SPECIFICATIONS

Roller Grill shall be stainless steel construction and use a special non-slip *Gripslt* rollers and tubular heating elements. One element shall be contained in each roller. Unit shall have a sealed motor with ball bearings for long life. Each roller shall have a PTFE end bearing and silicone grease barrier combination. The unit shall be equipped with two indicator lights and operate on 120V (60Hz) with one 6' cord and NEMA 5-15P (8050SX-RC) or 5-20P (8075SX-RC). This Roller Grill shall carry the approval of ETL, ETL CSA and shall be listed with the National Sanitation Foundation.