



**Chicken Slicer 3/8" Slices
N55650-CS
OPERATING INSTRUCTIONS**

Important

1. To get the best operation and life from your machine, please read and comply with these instructions.
2. Clean machine thoroughly before and after each use using cleaning instructions below.
3. Minimize the use of alkaline cleaners as they may cause pitting and dulling of the finish.

Safety Instructions

The blades are VERY SHARP! Be careful when handling and operating the machine to keep hands away from the blades.

Preparation

1. The LEVER is locked in the down position (as it is shipped) for safety and convenience by inserting PIN through the HOLE in the LEVER.
2. The LEVER can be locked in the up position to safely and conveniently remove the BLADE AND HOLDER ASSEMBLY by raising the LEVER so HOLE aligns with the holes in LINK BARS and inserting the PIN through all three parts.
3. Place the unit on a good firm work surface.
4. If unit fails to work properly when first operated call NEMCO customer service at 1-800-782-6761

Operation

1. Insert PIN into HOLE in LEVER.
2. Hold LEVER in its UP position and place the product on the BLADES.
3. Remove hand from the cutting area and firmly bring LEVER down, to cause the PUSH PLATE to force the product through the BLADES.

Cleaning

1. Remove PIN, move LEVER out of the way and lift PUSH PLATE off the GUIDE RODS.
2. Release and raise HOLD DOWN CLIPS and lift the BLADE AND HOLDER ASSEMBLY off the FRAME.
NOTE: The BLADE AND HOLDER ASSEMBLY can be totally disassembled for cleaning by removing the machine screws on the underside (see To Replace Blades for re-assembly instructions).
3. Reassemble by reversing the above procedure.

To Lubricate

If the PUSH PLATE doesn't slide freely, lubricate the GUIDE RODS with mineral oil or food grade lubricant. Do not use cooking oil; it can get sticky!

To Replace Blades

1. Loosen and remove all of the screws at the front of the BLADE AND HOLDER ASSEMBLY. Remove the screws at the rear of the assembly.
2. Remove the tension rods to release the BLADES.
3. Install replacement BLADES into the TENSION BLOCKS with the sharp side of the BLADES and the grooves in the TENSION BLOCK up. Be careful of the sharp edges!
4. Lay the BLADE HOLDER on a table with the bottom side upward. Place the BLADES with the TENSION BLOCKS installed into the BLADE HOLDER with the sharp side of the BLADES downward.
5. Install BEARING PLATES on the screws and install the screws into the BLADE HOLDER. NOTE: the short end of the BEARING PLATE must be toward the center of the FRAME.
6. Loosely install all of the screws into the TENSION BLOCKS.
7. Tighten the screws at the back (notched) side of the BLADE HOLDER.
8. Tighten the screws at the front to be snug. Then tighten and retighten until all are very tight and all of the BLADES are tightened equally. NOTE: If a torque wrench is available, set the adjusting screws to 60 inch pounds.

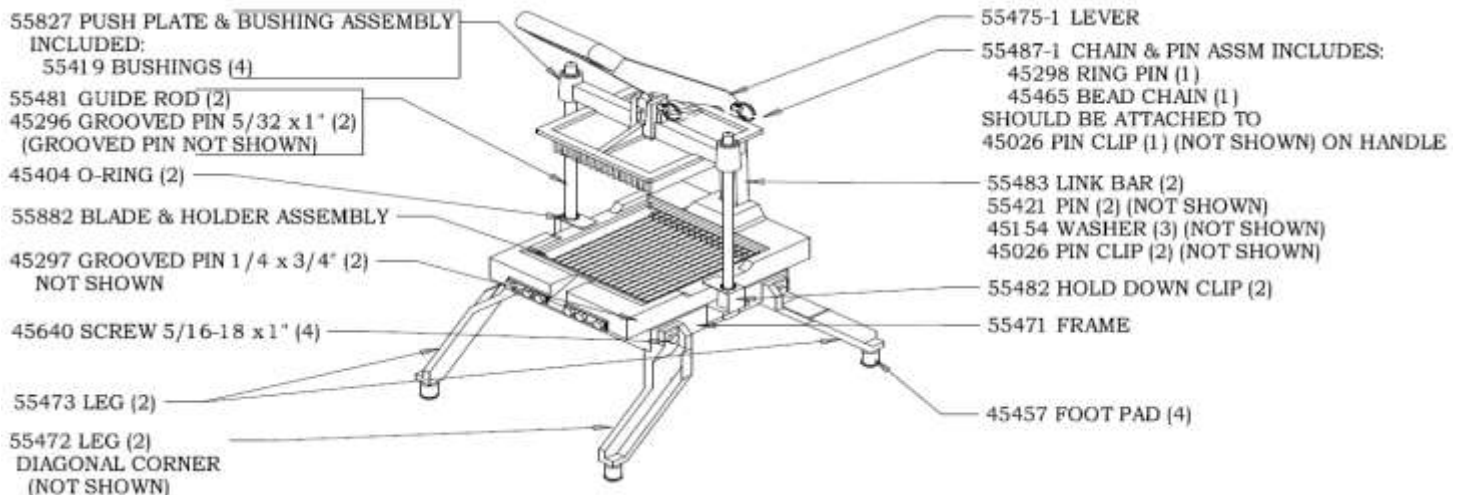

NEMCO FOOD EQUIPMENT
Phone: (419) 542-7751

301 Meuse Argonne, Hicksville, OH 43526
Fax: (419) 542-6690
www.nemcofoodequip.com

Toll free : 1-800-782-6761