

FEATURES

- High quality stainless steel body
- Gravity cooling system
- Includes hydraulic glass door cover that can be lifted to create a sneeze guard
- Fits 8 PCs of 1/6 size pan inserts (pans included)
- Dixell digital temperature controller



NTR-30

TEMPERATURE

- Interior temperature range: 2°C to 12°C (36°F to 54°F)



Model NTR-30

Refrigerated Topping Rail

WARRANTY

- 2 years parts and labour
7 years compressor warranty

Project: _____

Date: _____

Price: _____

SPECIFICATIONS

Volts (V)	Watts (W)	Amps (A)	Volume (cu./ft)	Refrigerant	Overall Dimensions			Interior Dimensions			Weight	
					Width	Depth	Height	Width	Depth	Height	Net	Gross
115V	110W	1A	N/A	R290	30	24	13	N/A	N/A	N/A	80 LBS	N/A

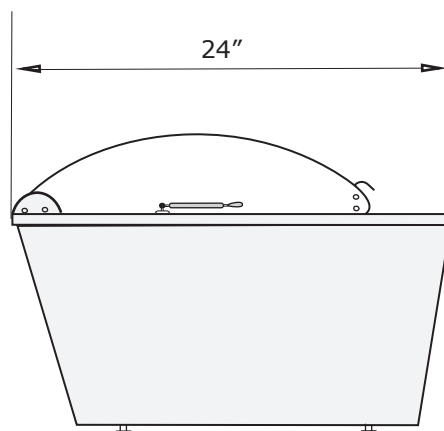
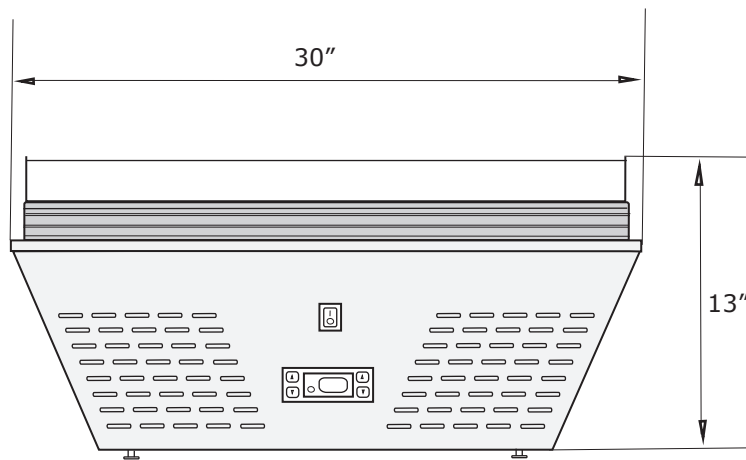

Refrigerated Topping Rail

Model NTR-30

CERTIFICATIONS:

