

## FEATURES

- Low velocity fan cooling system to prevent food dehydration
- Rear glass sliding doors for easy access
- Self-evaporation water tray
- Includes 2 chrome plated wire shelves
- LED interior lighting
- Double layered glass
- Exterior air duct to eliminate condensation
- Digital temperature controller



NSCP-27

## TEMPERATURE

- Interior temperature range: 0°C to 12°C (32°F to 54°F)

## WARRANTY

- 2 years parts and labour  
7 years compressor warranty

Project: \_\_\_\_\_

Date: \_\_\_\_\_

Price: \_\_\_\_\_

## SPECIFICATIONS

Volts (V)	Watts (W)	Amps (A)	Volume (cu./ft)	Refrigerant	Overall Dimensions			Interior Dimensions			Weight	
					Width	Depth	Height	Width	Depth	Height	Net	Gross
115V	160W	1.4A	4.2	R600a	27.5	22.5	27	N/A	N/A	N/A	150 LBS	N/A

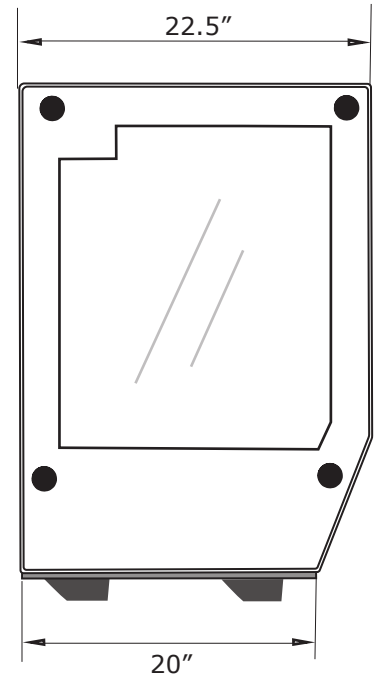
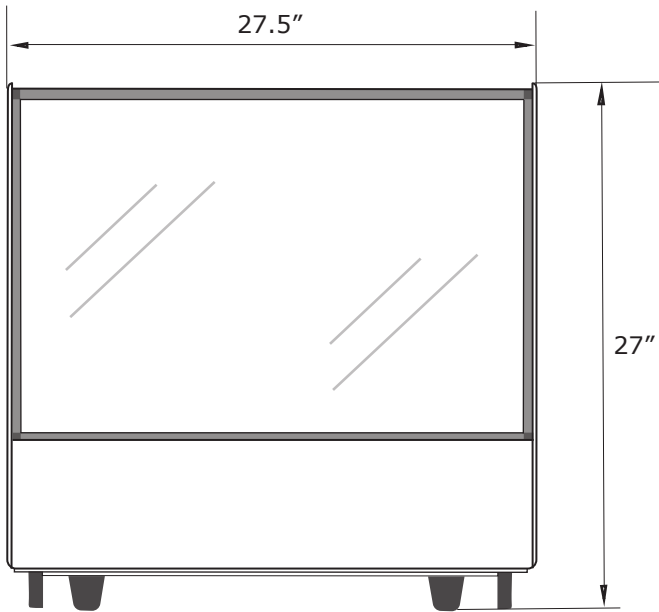

Square Counter Top Glass Display Pastry Case

Model NSCP-27

CERTIFICATIONS:

