

FEATURES

- High quality painted white steel body
- Coated evaporator coil for better protection against refrigeration leaks
- Perfect for merchandising beverages, sandwiches and more
- LED interior lighting on each shelf for maximum product visibility
- Tempered glass sides
- Glass front guard
- Includes 2 adjustable shelves
- Includes 4 casters, 2 with brakes
- Includes retractable curtain to save energy outside of operating hours
- Digital temperature controller with automatic defrost



NOR- 190

Model NOR- 190

Open Air Refrigerator

TEMPERATURE

- Interior temperature range: 2°C to 10°C (36°F to 50°F)

WARRANTY

- 2 years parts and labour
7 years compressor warranty

Project: _____

Date: _____

Price: _____

SPECIFICATIONS

Volts (V)	Watts (W)	Amps (A)	Volume (cu./ft)	Refrigerant	Overall Dimensions			Interior Dimensions			Weight	
					Width	Depth	Height	Width	Depth	Height	Net	Gross
120V	1300W	11A	6.7	R290	27.5	32.5	64.5	N/A	N/A	N/A	270 LBS	N/A

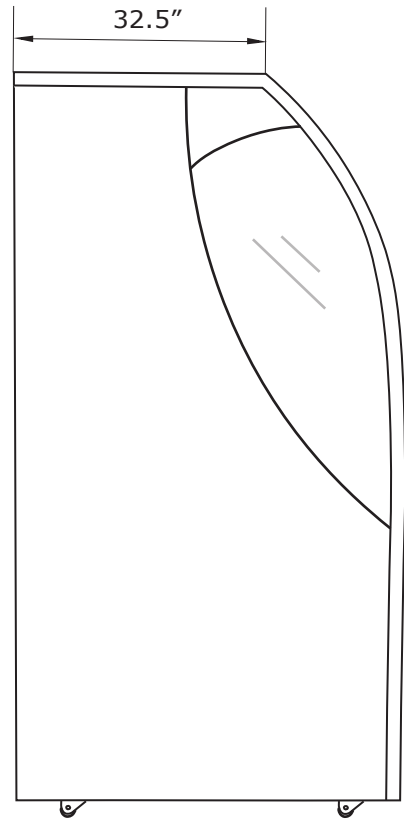
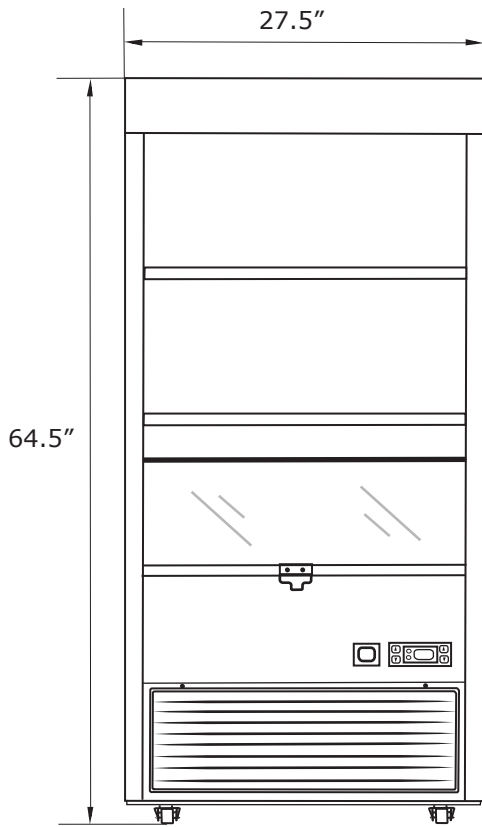

Open Air Refrigerator

Model NOR- 190

CERTIFICATIONS:



NEMA 5-15P

Local: 905-669-8003
Toll Free: 1-833-669-8003

2884 Slough Street, Unit 1
Mississauga, ON Canada