

## FEATURES

- White frame & cabinet
- Painted white aluminium interior
- Double layer glass door
- Fan forced cooling system
- Interior LED lighting
- Self-closing swing door
- Includes 2 epoxy coated shelves
- Digital temperature controller & defrost timer



NCF-49

## TEMPERATURE

- Interior temperature range: -13°C to -22°C (9°F to -8°F)



## WARRANTY

- 2 years parts and labour  
7 years compressor warranty

Project: \_\_\_\_\_

Date: \_\_\_\_\_

Price: \_\_\_\_\_

## SPECIFICATIONS

Volts (V)	Watts (W)	Amps (A)	Volume (cu./ft)	Refrigerant	Overall Dimensions			Interior Dimensions			Weight	
					Width	Depth	Height	Width	Depth	Height	Net	Gross
115V	210W	1.8A	1.9	R290	24.5	22.5	21.5	N/A	N/A	N/A	77 LBS	N/A

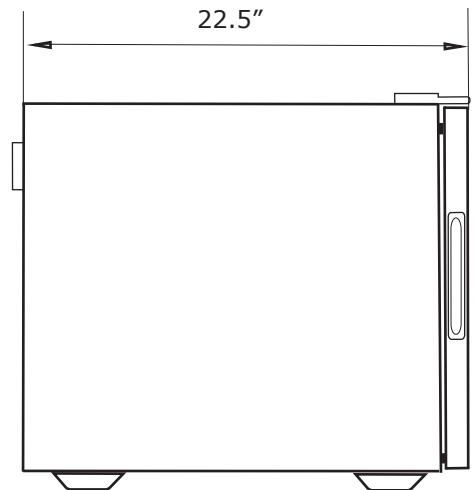
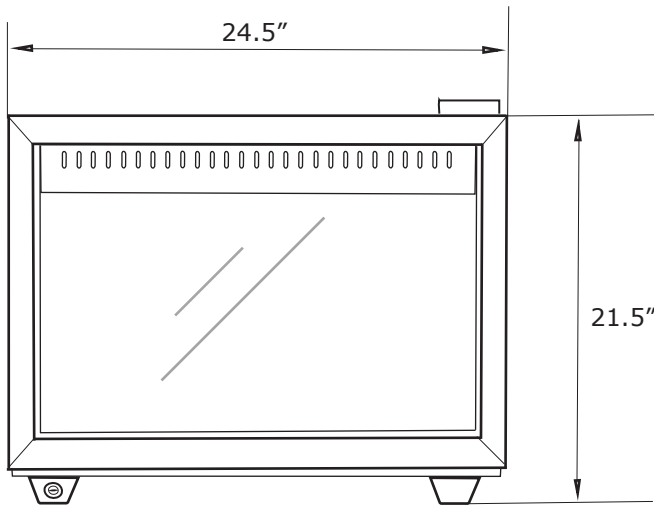

Counter Top Display Freezer

Model NCF-49

### CERTIFICATIONS:



NEMA 5-15P

Local: 905-669-8003  
Toll Free: 1-833-669-8003

2884 Slough Street, Unit 1  
Mississauga, ON Canada