

FEATURES

- Low profile front design for increased viewing area
- Rear glass sliding doors for easy access
- Self-evaporation water tray
- Includes 2 chrome plated wire shelves
- LED interior lighting
- Double layer glass to reduce condensation
- Low velocity fan cooling system to prevent food dehydration
- Digital temperature controller



NACP-27

TEMPERATURE

- Interior temperature range: 0°C to 12°C (32°F to 54°F)



WARRANTY

- 2 years parts and labour
7 years compressor warranty

Project: _____

Date: _____

Price: _____

SPECIFICATIONS

Volts (V)	Watts (W)	Amps (A)	Volume (cu./ft)	Refrigerant	Overall Dimensions			Interior Dimensions			Weight	
					Width	Depth	Height	Width	Depth	Height	Net	Gross
115V	180W	1.6A	4.6	R600a	27.5	22.5	27	N/A	N/A	N/A	150 LBS	N/A

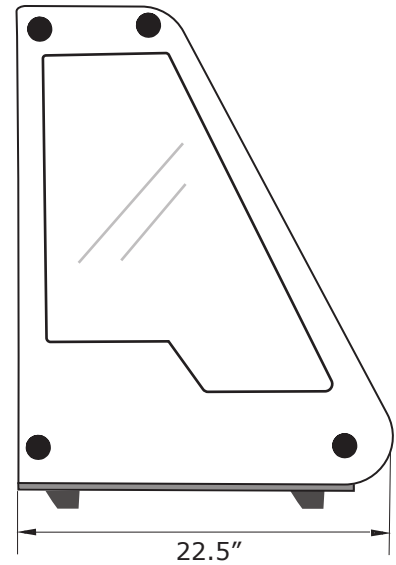
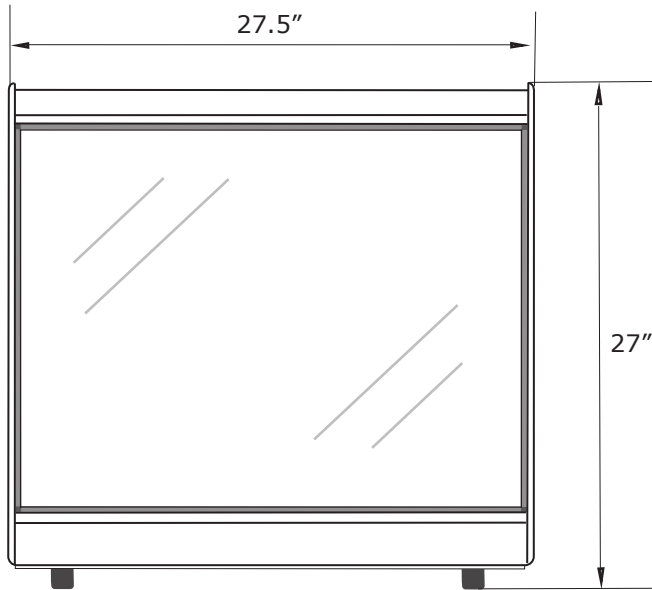

Angled Counter Top Glass Display Pastry Case

Model NACP-27

CERTIFICATIONS:

