

FEATURES

- Black steel body with insulated & lockable doors
- Stainless steel interior & work top
- Fan forced cooling system
- Interior LED lighting
- Self-evaporation water tray
- Side mounted compressor & condensing unit
- 1 dispensing tower with 2 taps (2 taps total)
- Capacity: 2 x 1/2 barrels
- Includes adjustable feet and 4" casters
- Removable installation board for easy cleaning & service
- Dixell digital temperature controller
- Heavy duty 1/5 HP Embraco compressor



KGR-28-59

TEMPERATURE

- Interior temperature range: 0°C to 8°C (32°F to 46°F)

WARRANTY

- 2 years parts and labour
7 years compressor warranty
- Extended warranty options available

Project: _____

Date: _____

Price: _____

Model KGR-28-59

Keg Beer Dispensing Cooler

SPECIFICATIONS

Volts (V)	Watts (W)	Amps (A)	Volume (cu./ft)	Refrigerant	Overall Dimensions			Interior Dimensions			Weight	
					Width	Depth	Height	Width	Depth	Height	Net	Gross
115V	333W	2.9A	19	R290	59	28	40	N/A	N/A	N/A	370 LB	N/A

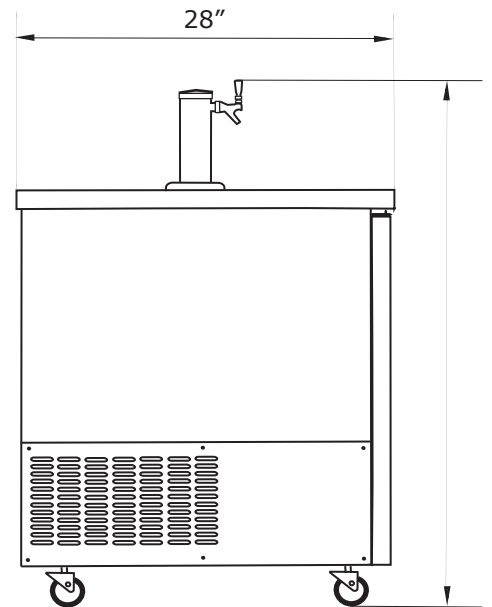
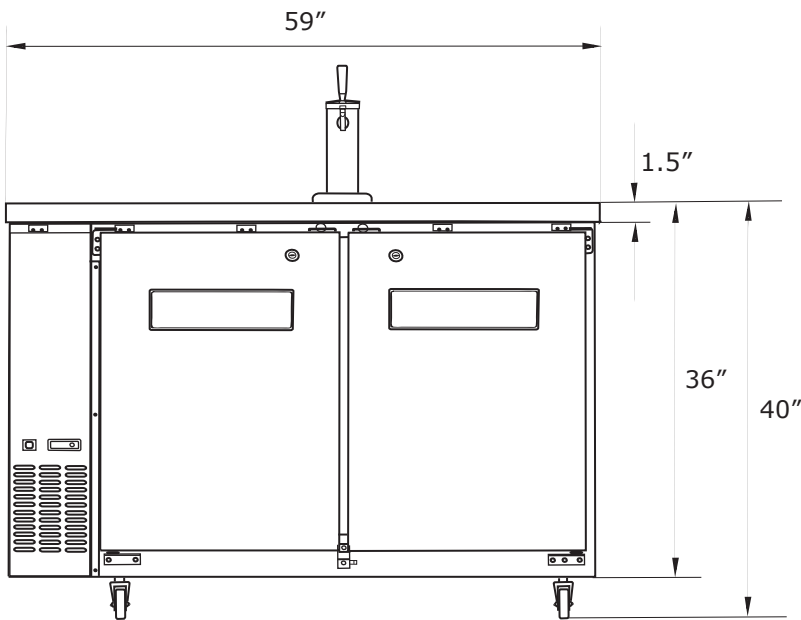

Keg Beer Dispensing Cooler

Model KGR-28-59

CERTIFICATIONS:

