



Gas CONVECTION OVEN

Features

- 3 inshot burners, 18,000 BTU each-total 54,000 BTU
- Electronic thermostat (FAST) & manual timer control
- Temperature range: 150°-500°F (66°-260°C)
- Independent doors with full view windows
- 2-speed, ½ HP fan motors (1725, 1140rpm) for even heat distribution and forced "cool down" fan mode
- Porcelain enamel oven interior for easy cleaning
- Stainless steel front, sides & top exterior
- 5 nickel plated Heavy Duty racks, 11 rack positions
- **Available in Natural gas(NG) or Liquid propane(LP)**
- **A conversion kit is supplied with each unit**



IGCO



IGCO-2





Gas CONVECTION OVEN

Dimensions in inches

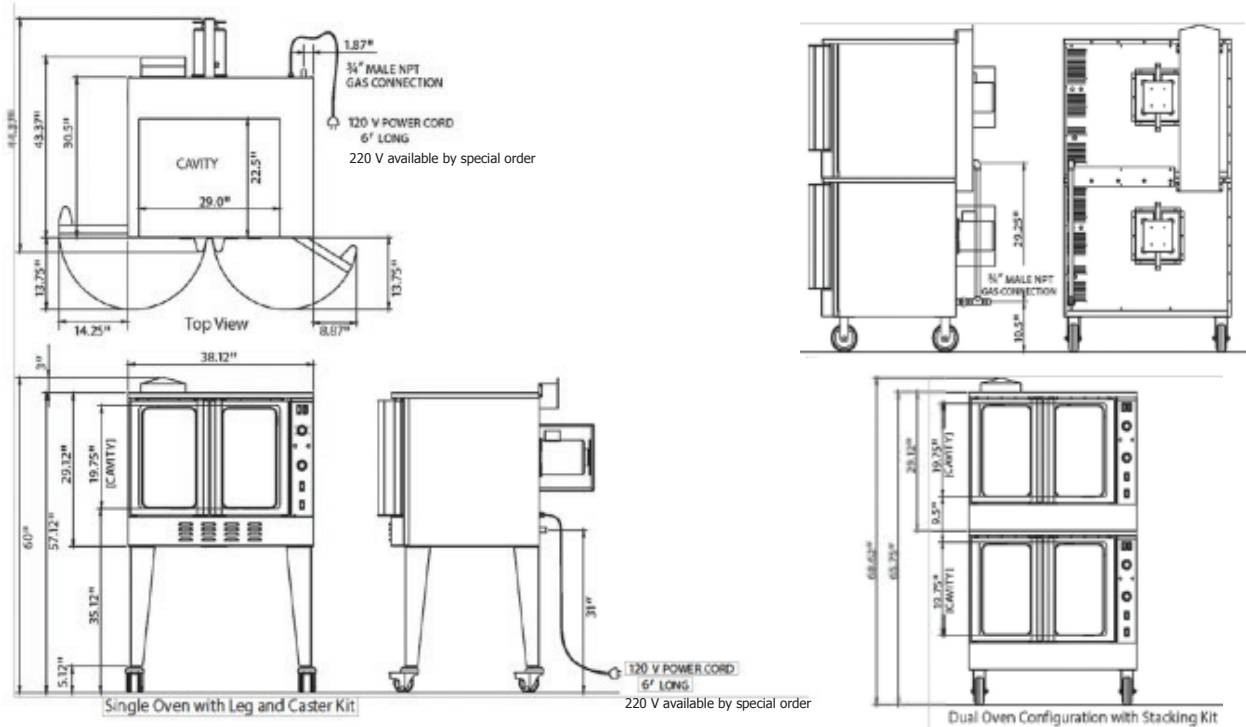

Specifications



Model	Overall Dimensions	Oven Interior	Rack Clearance	Shipping Crate(s)
IGCO	38.12\"W x 44.37\"D x 60\"H (96.8cm x 112.7cm x 152.4cm)	29\" W x 22.5\" D x 19.37\" H (74cm x 57cm x 50cm)	28\"W x 21\"D (72cm x 53.3cm)	45.3\"W x 49.2\" D x 37\" H, 48 cu ft., 511 lbs (115cm x 125cm x 99cm, 1.35 cu m., 232kgs)
IGCO-2	38.12\"W x 44.37\"D x 65.62\"H (96.8cm x 112.7cm x 166.7cm)	29\" W x 22.5\" D x 19.37\" H (74cm x 57cm x 50cm)	28\"W x 21\"D (72cm x 53.3cm)	2 Single Oven Crates, Total, 96cu ft., 1022 lbs. (2.7cu m., 464kgs.)

GAS REQUIREMENTS

- Natural Gas or Liquid Propane (LP) Gas main supply required
- A conversion kit is supplied with each unit. In order to avoid any warranty issues, conversion of your unit must be completed by an authorized Ikon service agent.
- 3/4\" NPT gas connection
- Natural gas 3.5\" W.C., LP gas 10\" W.C.
- IGCO Includes leg and caster kit
- IGCO-2 Includes stacking kit

Leg or Stacking Kits	Shipping Carton	Weight
IGCO SINGLE LEG AND CASTER KIT	29.9\"W x 18.1\"D x 8.7\"H (76cm x 46cm x 22cm)	41lb 18.5kg
IGCO DUAL STACKING KIT	38.2\"W x 11.8\"D x 6.7\"H (97cm x 30cm x 17cm)	35lb 16kg