

FEATURES

- White steel interior & exterior with stainless steel framing
- Glass sneeze guard with stainless steel framing & top shelf
- LED lighting mounted to sneeze guard with on/off switch
- Includes anti-rotation tub holders & plastic covers
- Fits 22 ice cream tubs (12 for display & 10 for storage)
- Fits carton and ropak tubs
- Gravity cooling system
- Includes 3" locking casters
- Transparent roll top cover with full length handle
- Removable installation board for easy cleaning & service
- Digital temperature controller
- Heavy duty 1/2 HP Embraco compressor



IDF-68

TEMPERATURE

- Interior temperature range: -15°C to -23°C (5°F to -9°F)

WARRANTY

- 2 years parts and labour
7 years compressor warranty
- Extended warranty options available

Project: _____

Date: _____

Price: _____

Model IDF-68

Ice Cream Dipping Freezer

SPECIFICATIONS

Volts (V)	Watts (W)	Amps (A)	Volume (cu./ft)	Refrigerant	Overall Dimensions			Interior Dimensions			Weight	
					Width	Depth	Height	Width	Depth	Height	Net	Gross
115V	649W	5.64A	N/A	R290	68	28	51	N/A	N/A	N/A	420 LBS	N/A

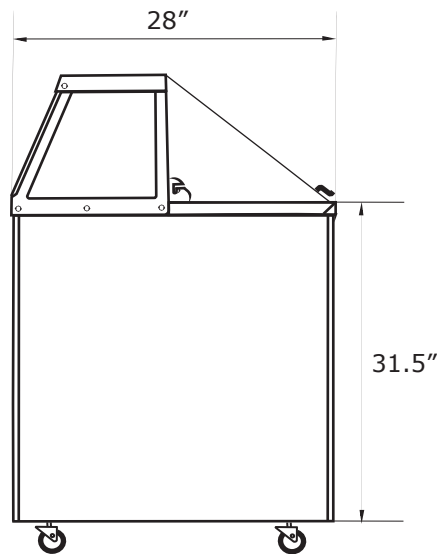
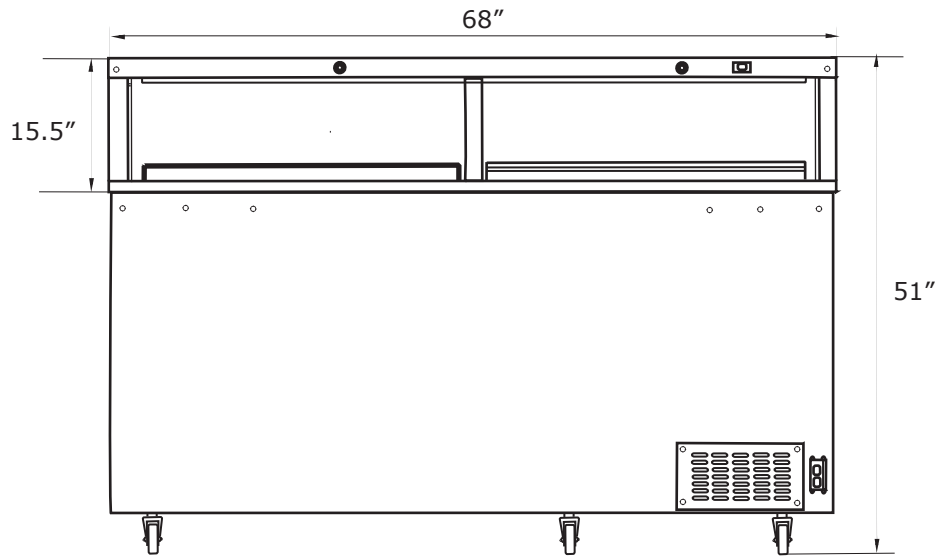

Ice Cream Dipping Freezer

Model IDF-68

CERTIFICATIONS:



NEMA 5-15P