

MVP GROUP CORPORATION
www.mvpgroupcorp.com





MVP GROUP CORPORATION

5659 Royalmount Ave. Montreal, QC, Canada H4P 2P9
Telephone: (514) 737-9701 Toll Free Telephone: (888) 275-4538

Fax: (514) 342-3854 Toll Free: (877) 453-8832

Email:
sales@mvpgroupcorp.com
Website:
www.mvpgroupcorp.com

12000 Biscayne Blvd. Ste 108
Miami, FL 33181
Telephone (786) 600-4687
Toll Free 1-844-218-8477
Fax (786) 661-4100

This page has been left blank intentionally.

INDEX

1	General information	5
1.1	Case description	5
2	Getting started with your KFM series	15
2.1	Location	15
2.2	Uncrating	16
2.2.1	Front and sides assemblies	17
2.3	Check for damage	19
2.4	Control panel and main features	20
2.5	Check serial, model numbers and requested options	22
2.6	Warning/Caution labels	24
2.7	Check your electrical installation	28
2.8	Electrical, drain and refrigeration connections (remotes only)	28
2.9	Joining	29
2.10	Plugging and start	37
3	Refrigeration	39
3.1	Self contained refrigeration equipment and defrost	39
3.2	Refrigeration loads (remotes only)	41
4	Electrical	41
4.1.	Electrical specifications data	41
4.2.	Electrical service receptacles (optional)	43
4.3.	Electrical diagrams	44
4.4.	Electronic controller	50
5	Maintenance	53
5.1	Exterior cleaning	53
5.2	Interior cleaning	54
5.3	Shelf removing	54
5.4	Back Sliding doors removal	55
5.5	Light substitution	56
5.6	Panels and protection grille removal	57
5.7	Condenser cleaning	57
5.8	Evaporator cleaning	58
5.9	Evap Pan cleaning	58
5.10	Drain inspection	59
5.11	Glass type conversion model	59
6	Troubleshooting/Service	60
6.1	Troubleshooting	60
6.2	Service	61
7	Warranty	63
8	Notes	64

This page has been left blank intentionally.

This page has been left blank intentionally.

This page has been left blank intentionally.

7 Warranty

12 month warranty for all parts from the invoice date. A new part will be provided free of charge. Defective part must be returned to the manufacturer.

Warranty claims: All claims must include model number, serial number, date of purchase, date of installation and additional information about the supposed defect.

All service work must be authorized by MVP group.

MVP group reserves the right to select the service company.

Loss of food or other damages caused by faulty equipment aren't covered by this warranty.

Warranty does not cover damage when uncrating.

Work made necessary, by lack of maintenance or cleaning are not covered by this warranty.

Warranty does not cover damage or malfunction result of improper use or installation.

Warranty does not cover negligence, misuse and operation on wrong voltage.

Warranty does not apply if the serial number is altered or defaced.

Failure to comply with the instructions in this manual shall avoid warranty.

KPM SERIES

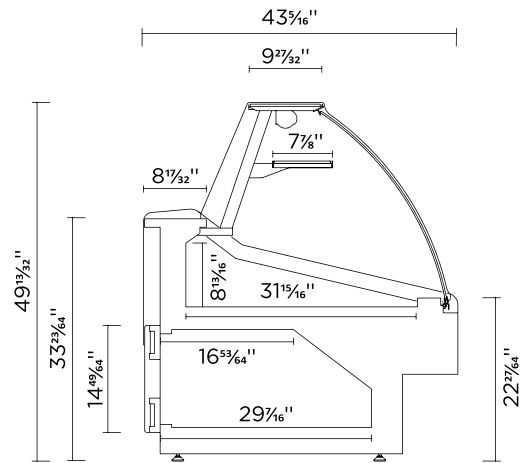

KPM-CG-S(R)(D)



KPM-CG-S(R)(D)

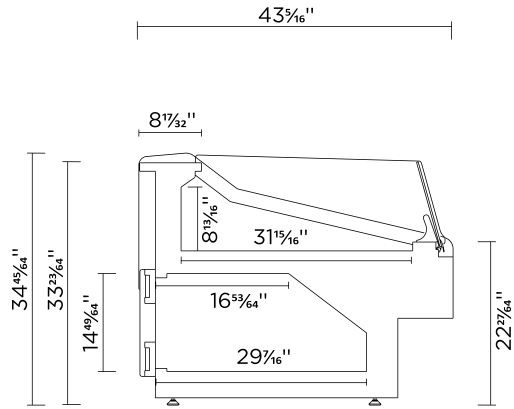

KPM-OF-S(R)(D)



KPM-OF-S(R)(D)

Equipment runs constantly:

- Condenser dirty.
- Condenser fan malfunction.
- Temperature and relative humidity too high.

Starting relay burns out:

- Low voltage.
- High voltage.
- Compressor short cycles.
- Incorrect running capacitor.
- Incorrect relay.

Head pressure too high:

- Unit overcharged.
- Air or other non condensable gases in the system.
- Clogged condenser.
- Defective condenser fan motor.
- Unit location too hot.
- Restriction in charge line.

Head pressure too low:

- Insufficient refrigerant charge.
- Leak in the system.
- Cold location.

Noisy unit:

- Compressor oil charge low.
- Fan blade causing vibrations.
- Tube rattle.
- Loose parts.
- Case not leveled.

6.2 Service



This operation must be performed by a qualified technician.



For spare parts, contact your distributor.

6.1 Troubleshooting

 Service must be performed by a qualified technician.

Doors not closing:

Check for leveled floor.

Check for obstruction.

Remove doors and check the bearings.

Lights not working:

Check light switch position.

Check light connections.

Warm case temperature:

Check for air return grille obstruction.

Check for air drafts.

Check store temperature.

Check for condenser obstruction and cleaning.

Check for frozen evaporator.

Check set point.

Display area is over filled.

Fans not working:

Check electrical connections.

Check for any debris.

Case not aligning:

Check for leveled floor.

Check instructions for joining.

Display not working:

Check main power switch position..

Check electrical connections.

Compressor not starting:

Disconnect switch open.

Blown fuse.

Overload protective tripped.

Low charge of refrigerant.

Relay defective.

Implantation



Drain outlet



Electrical board



Refrigeration piping

To access the evap pan:

- Remove protection grille.
- Unplug the evap pan.
- Relieve the screws and take the evap pan off.
- Clean with soft detergent or warm water.

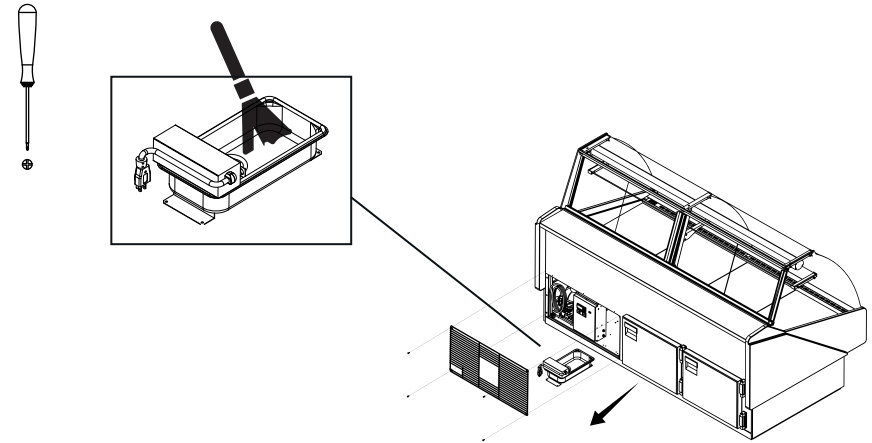

Front

5.10 Drain inspection

- ⚠ Check for drain obstruction and correct position every month (Remotes only).

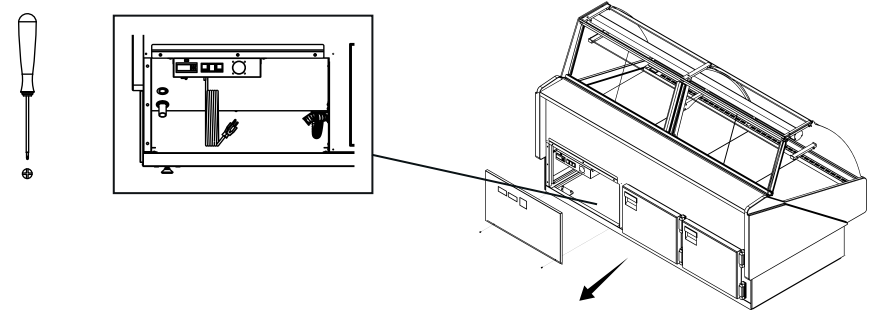

5.11 Glass type conversion model

- ⚠ This operation must be performed by a qualified technician.
- ⚠ Contact distributor for specific manual to assist in conversion.

KPM-CG-xx-R



5.8 Evaporator cleaning

- ⚠ This operation must be performed by a qualified technician.
- ⚠ All operations must be done with the unit disconnected.

To access the evaporator:

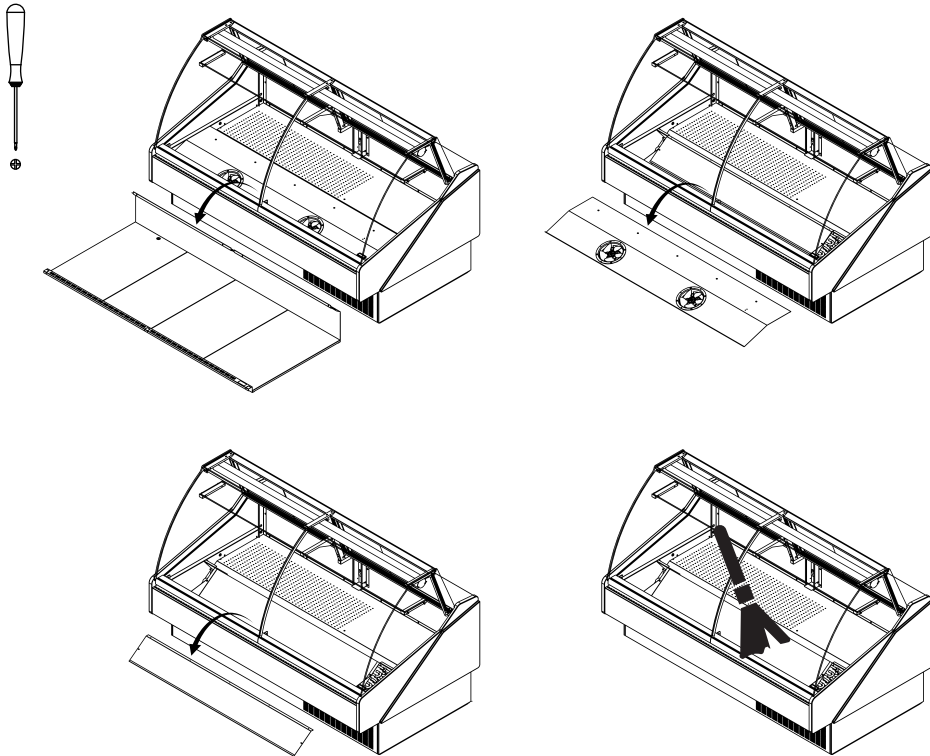
- Open your unit
- Lift and remove exposition panels
- Use tool for the screws and clean



-  Drain outlet
-  Electrical board
-  Refrigeration piping

5.9 Evap Pan cleaning

- ⚠ This operation must be performed by a qualified technician.
- ⚠ All operations must be done with the unit disconnected.
- ⚠ Pan can be hot!
- ⚠ This operation must be done weekly.

KPM-FG-xx-S

↑ Front

5.6 Panels and protection grille removal

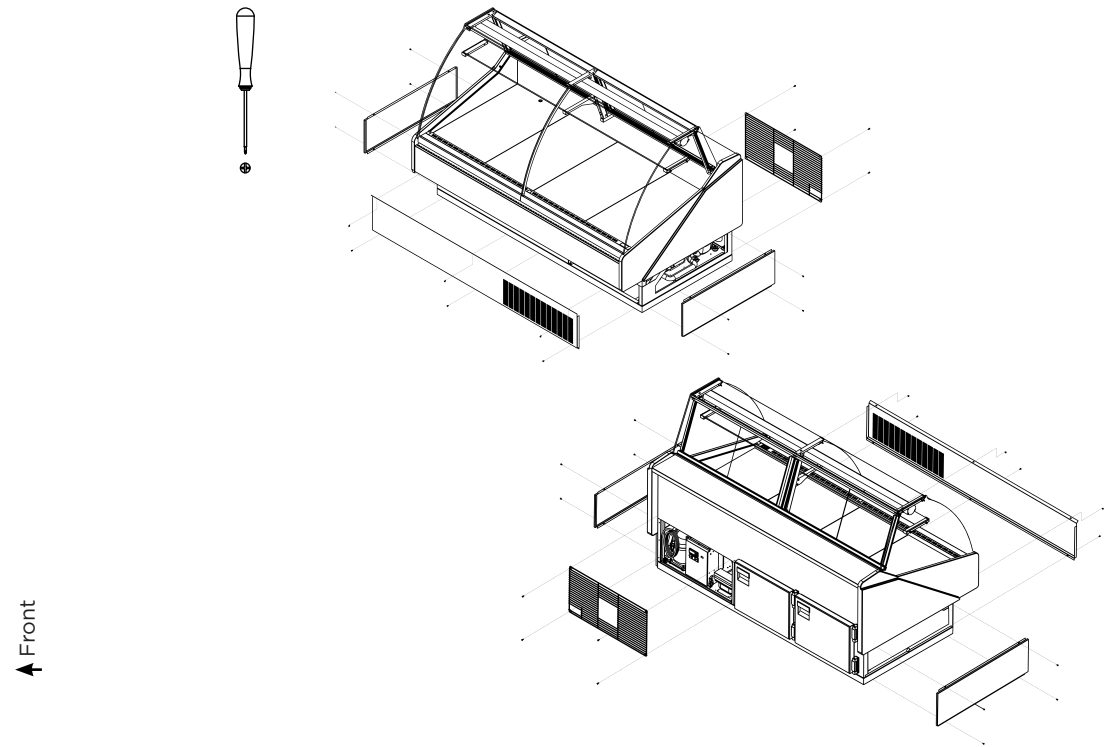

5.7 Condenser cleaning

- ⚠ This operation must be performed by a qualified technician.
- ⚠ All operations must be done with the unit disconnected.

Condenser must be regularly cleaned (every month). Use a brush or vacuum it. To get to the condenser must remove frontal panel.

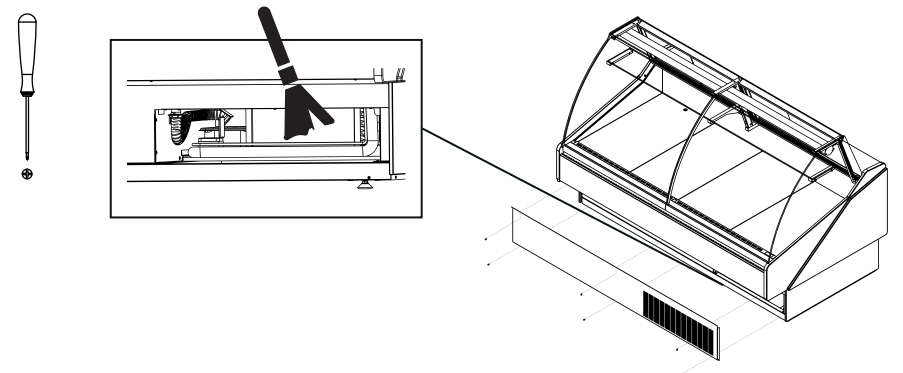

KPM-FG-xx-R

5.5 Light substitution

To replace lights follow the steps:

 All operations must be done with the unit disconnected.

- Disconnect the light
- Unscrew the light holder and remove the light
- Insert a new light in the same place of the old one, screw the holder connect it
- Screw the light and connect it
- Plug and turn on the light

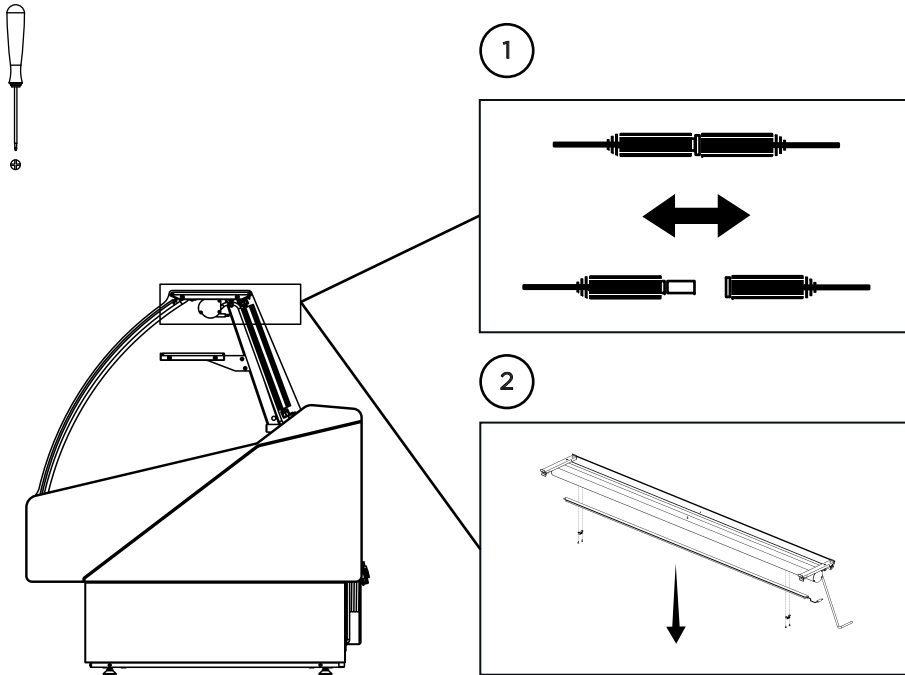

 Drain outlet

 Electrical board

 Refrigeration piping

 Electrical wiring

↑ Front

KPM-OF-xx-S

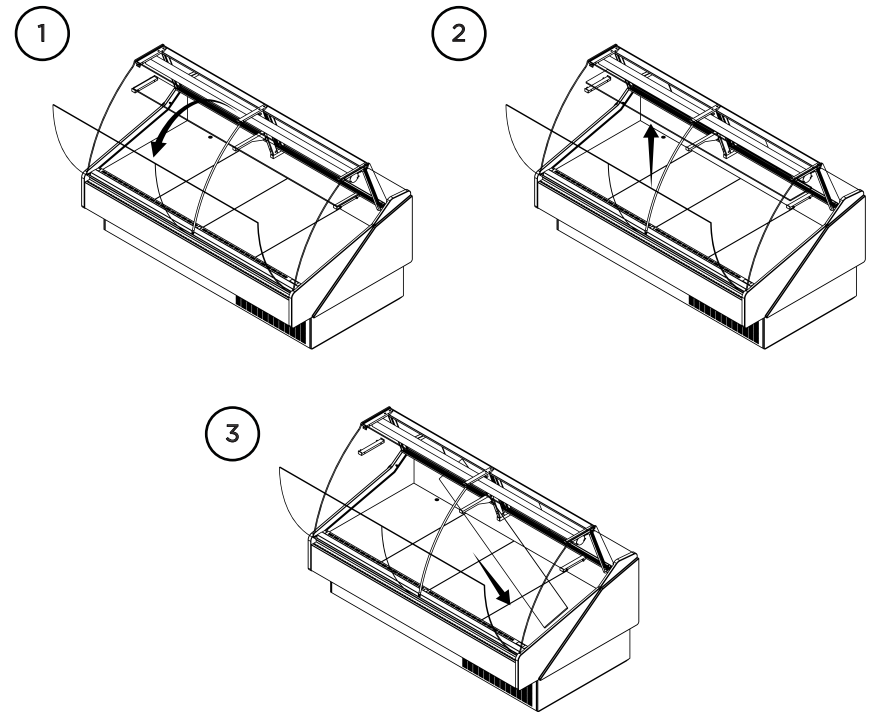

↑ Front

5.4. Back Sliding doors removal

Back sliding doors are easy to take off.
 - Grab door push up and then tilt the bottom towards you.

To put the door back on, just reverse the previous step.

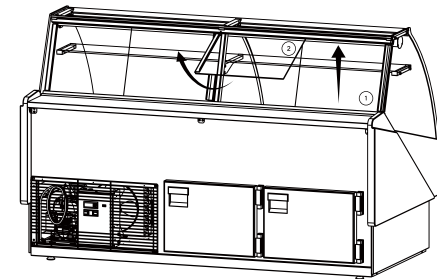

KPM-OF-xx-R

For easier cleaning remove the front glass (instructions below).

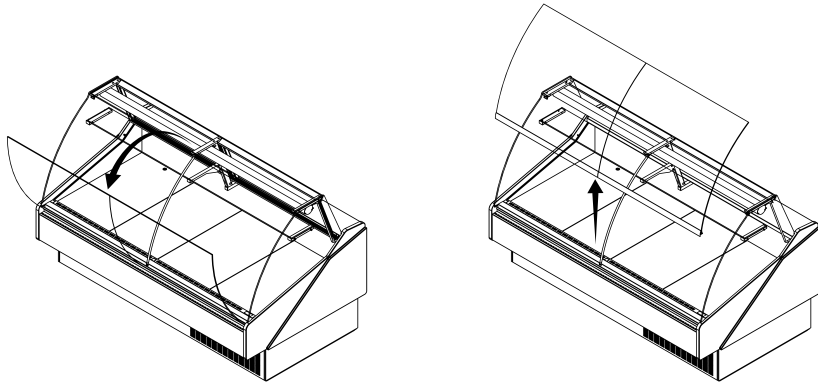

5.2 Interior cleaning

⚠ All operations must be done with the unit disconnected.

Clean surfaces (glass/metal/plastic) with soft detergent or warm water. Do not use abrasive cleanser.

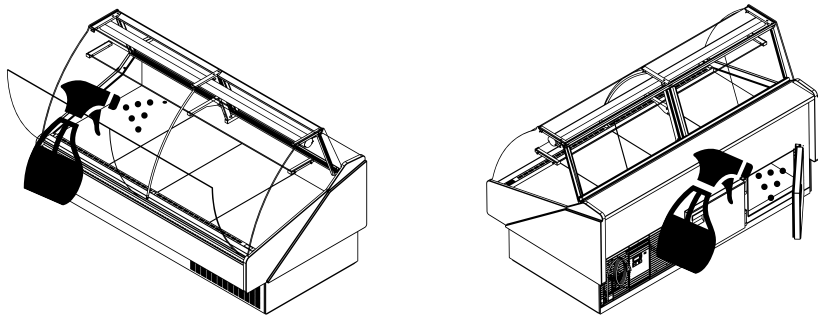

5.3 Shelf removing

⚠ All operations must be done with the unit disconnected.

To remove or adjust shelves take care with light connections.

KPM series intended for deli, meat and fish are type 1 equipment - 75°F/55%RH. Temperature of the deli and meat cases is set for 32°F. The decks have a 31 lb/ft² loading limit. Glass shelves are for non refrigerated products only and have a 5,5 lb/ft² loading limit.

Model	Dimensions (LxDxH in inches)	Service dimensions (LxDxH in inches)	Volume (ft ³)
KPM-CG-60-S(R)(D)	60 ¹ / ₁₆ " x 49 ⁹ / ₁₆ " x 61 ¹ / ₁₆ "	60 ¹ / ₁₆ " x 49 ⁹ / ₁₆ " x 75 ⁷ / ₈ "	9,3/5,33
KPM-CG-80-S(R)(D)	77 ⁹ / ₁₆ " x 49 ⁹ / ₁₆ " x 61 ¹ / ₁₆ "	77 ⁹ / ₁₆ " x 49 ⁹ / ₁₆ " x 75 ⁷ / ₈ "	12,1/8,76
KPM-CG-100-S(R)(D)	101 ³ / ₁₆ " x 49 ⁹ / ₁₆ " x 61 ¹ / ₁₆ "	101 ³ / ₁₆ " x 49 ⁹ / ₁₆ " x 75 ⁷ / ₈ "	16,0/13,41
KPM-FG-60-S(R)(D)	60 ¹ / ₁₆ " x 44 ¹ / ₂ " x 61 ¹ / ₁₆ "	60 ¹ / ₁₆ " x 44 ¹ / ₂ " x 82 ³ / ₈ "	9,3/5,33
KPM-FG-80-S(R)(D)	77 ⁹ / ₁₆ " x 44 ¹ / ₂ " x 61 ¹ / ₁₆ "	77 ⁹ / ₁₆ " x 44 ¹ / ₂ " x 82 ³ / ₈ "	12,1/8,76
KPM-FG-100-S(R)(D)	101 ³ / ₁₆ " x 44 ¹ / ₂ " x 61 ¹ / ₁₆ "	101 ³ / ₁₆ " x 44 ¹ / ₂ " x 82 ³ / ₈ "	16,0/13,41
KPM-OF-60-S(R)(D)	60 ¹ / ₁₆ " x 34 ¹ / ₁₆ " x 61 ¹ / ₁₆ "	60 ¹ / ₁₆ " x 34 ¹ / ₁₆ " x 62 ¹ / ₁₆ "	9,3/5,33
KPM-OF-80-S(R)(D)	77 ⁹ / ₁₆ " x 34 ¹ / ₁₆ " x 61 ¹ / ₁₆ "	77 ⁹ / ₁₆ " x 34 ¹ / ₁₆ " x 62 ¹ / ₁₆ "	12,1/8,76
KPM-OF-100-S(R)(D)	101 ³ / ₁₆ " x 34 ¹ / ₁₆ " x 61 ¹ / ₁₆ "	101 ³ / ₁₆ " x 34 ¹ / ₁₆ " x 62 ¹ / ₁₆ "	16,0/13,41

2 Getting started with your KPM series

2.1 Location

To your new equipment perform well please respect the following warnings:

- ⚠** This is type 1 equipment, intended to work with 75°F / 55%RH.
- ⚠** This equipment is intended for maintaining temperature only.
- ⚠** Be sure products are not ambient temperature (must be cold)
- ⚠** This equipment must be located in an indoor environment.
- ⚠** Check for drafts and avoid them.
- ⚠** Air movement from ac units shouldn't be directed to the equipment.
- ⚠** The equipment must not be directly or indirectly exposed to the sun.
- ⚠** Check for rejected heat from another refrigeration units and avoid that.
- ⚠** Place the equipment in a levelled floor.
- ⚠** Do not obstruct the air way in front of the condenser.
- ⚠** Make sure there is a drain preparation (remotes and fish display cases only).

- ⚠ Models to be positioned against a wall keep a safe distance of 2³/₈".
- ⚠ After servicing always close the doors.
- ⚠ Make sure you have a suitable electrical installation.
- ⚠ This equipment should be handled by a qualified technician.

2.2 Uncrating

- ⚠ All operations must be done carefully.
- ⚠ All plastic protective films must be removed before using the equipment for the first time.

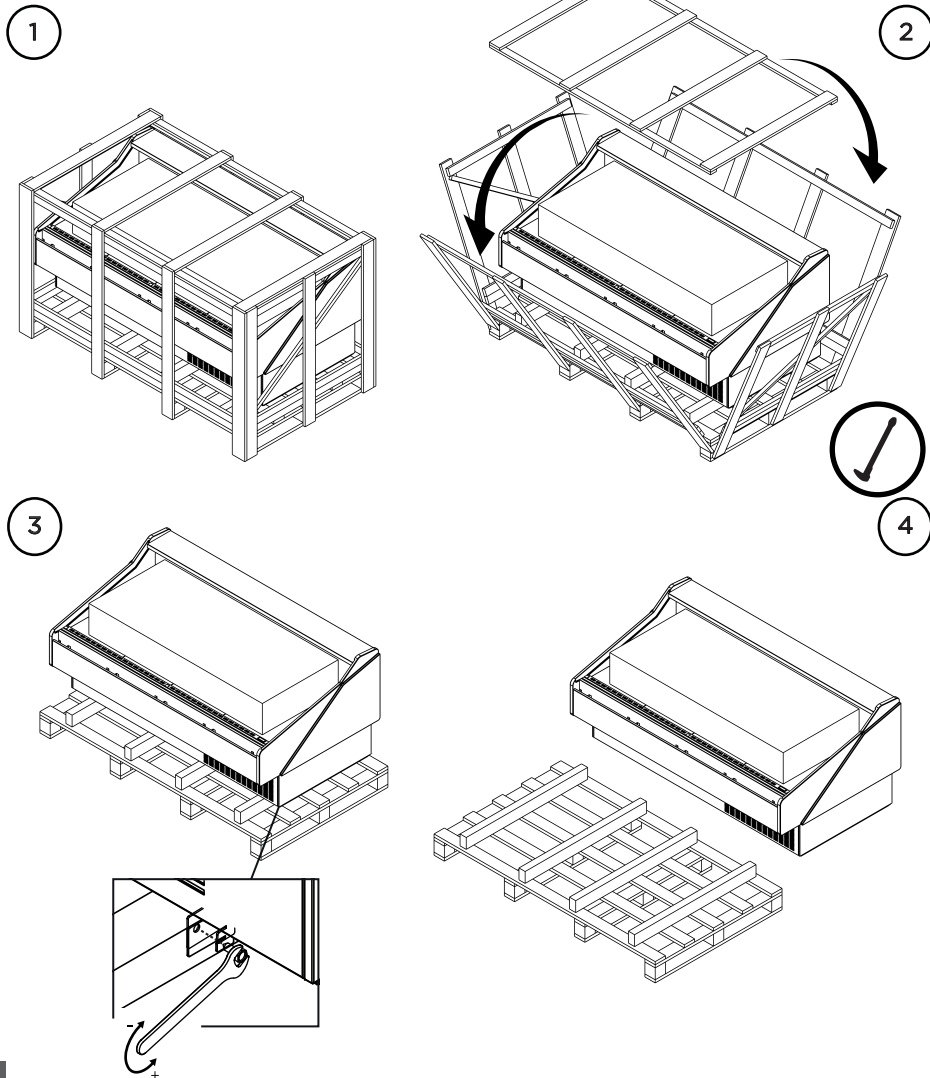

Main parameters

Symbol	Code	Parameter	Models	UOM	Type	Min	Max	Def
	/3	Probe display response	MSYF	-	C	0	15	0
	/5	Select °C or °F 0: °C 1: °F	MSYF	flag	C	0	1	0
🔑	/A2	Configuration of probe 2 (S2)	YF	-	C	0	4	2
		0: Probe absent 1: Product probe (display only) 2: Defrost probe 3: Condenser probe 4: Antifreeze probe	MS	-	C	0	4	2
	/c1	Calibration of probe 1	MSYF	°C/°F	C	-20	20	0,0
🌐	St	Temperature set point	MSYF	°C/°F	F	r1	r2	0,0
	rd	Control delta	SYF	°C/°F	F	0,1	20	2,0
🕒	c2	Minimum compressor OFF time	SYF	min	C	0	15	0
❄️	dl	Interval between defrosts	SYF	hours	F	0	250	8
	dP1	Maximum defrost duration, evaporator	SYF	min	F	1	250	30

5 Maintenance

5.1 Exterior cleaning

- ⚠ All operations must be done with the unit disconnected.

Clean surfaces (glass/metal/plastic) with soft detergents or warm water. Do not use abrasive cleanser.

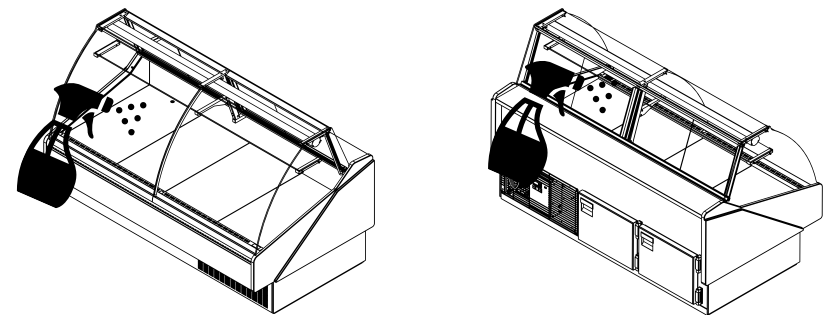

Signals on the display

The blinking status indicates a request for activation that cannot be implemented until the end of the corresponding delay times.

Icon	Function	ON	OFF	blink	Startup
	COMPRESS.	compressor ON	comp. OFF	compressor request	
	FAN	fan ON	fan OFF	fan request	
	DEFROST	defrost in progress	defrost not required	defrost request	
	AUX	auxiliary output AUX active	auxiliary output AUX not active	anti-sweat heater function active	
	ALARM	delayed external alarm (before the expiry of the time "A7")	no alarm present	alarms in normal operation (eg. high/low temp.) or alarm from ext. digital input immediate or delayed	
	CLOCK	at least one timed defrost has been set	no timed defrost is present	clock alarm	ON if Real-Time Clock present
	LIGHT	auxiliary output LIGHT ACTIVE	auxiliary output LIGHT NOT ACTIVE	anti-sweat heater function active	
	SERVICE		no malfunction	malfunction (eg. EEPROM error or probe fault)	
	HACCP	HACCP function	HACCP function enabled	HACCP alarm (HA and/or HF) not enabled	
	CONTINUOUS CYCLE	enabled	not enabled	request	

Controller must be handled by a qualified technician.

Buttons on the keypad

Normal operation

Button	Press. the button alone	Pressing together with other buttons
	<ul style="list-style-type: none"> if pressed for more than 5 s accessed the menu for setting type "F" (frequent) parameters in the event of alarm: silences the audible alarm (buzzer) and disables the alarm relay 	<ul style="list-style-type: none"> if pressed for more than 5 s together with the SET button, accesses the menu for setting the type "C" (configuration) or downloading the parameters if pressed for more than 5 s together with the UP/AUX button resets any alarm with manual reset
	if pressed for more than 1 s, enables/disables the auxiliary output	<ul style="list-style-type: none"> if pressed for more than 5 s together with DOWN/DEF button, enables/disables the continuous cycle operation if pressed for more than 5 s with SET button, starts the procedure for printing the reports (function available, with management to be implemented) if pressed for more than 5 s together with PRG/MUTE button, resets any active alarm with manual reset
	if pressed for more than 5 s, enables/disables a manual defrost	<ul style="list-style-type: none"> if pressed for more than 5 s together with UP/AUX button, enables/disables the continuous cycle operation if pressed for more than 1 s together with SET button, displays a submenu with the HACCP alarm parameters (HA, HAn, HF, HFn)
	if pressed for more than 1 s, displays and/or set the set point	<ul style="list-style-type: none"> if pressed for more than 5 s together with PRG/MUTE button, accesses the menu for setting the type "C" parameters "C" (configuration) or downloading the parameters if pressed for more than 1 s together with DOWN/DEF button, displays a submenu with the HACCP alarm parameters (HA, HAn, HF, HFn) if pressed for more than 5 s together with UP/AUX, starts the procedure for printing the report (function available, with management to be implemented)

2.2.1 Front and sides assemblies

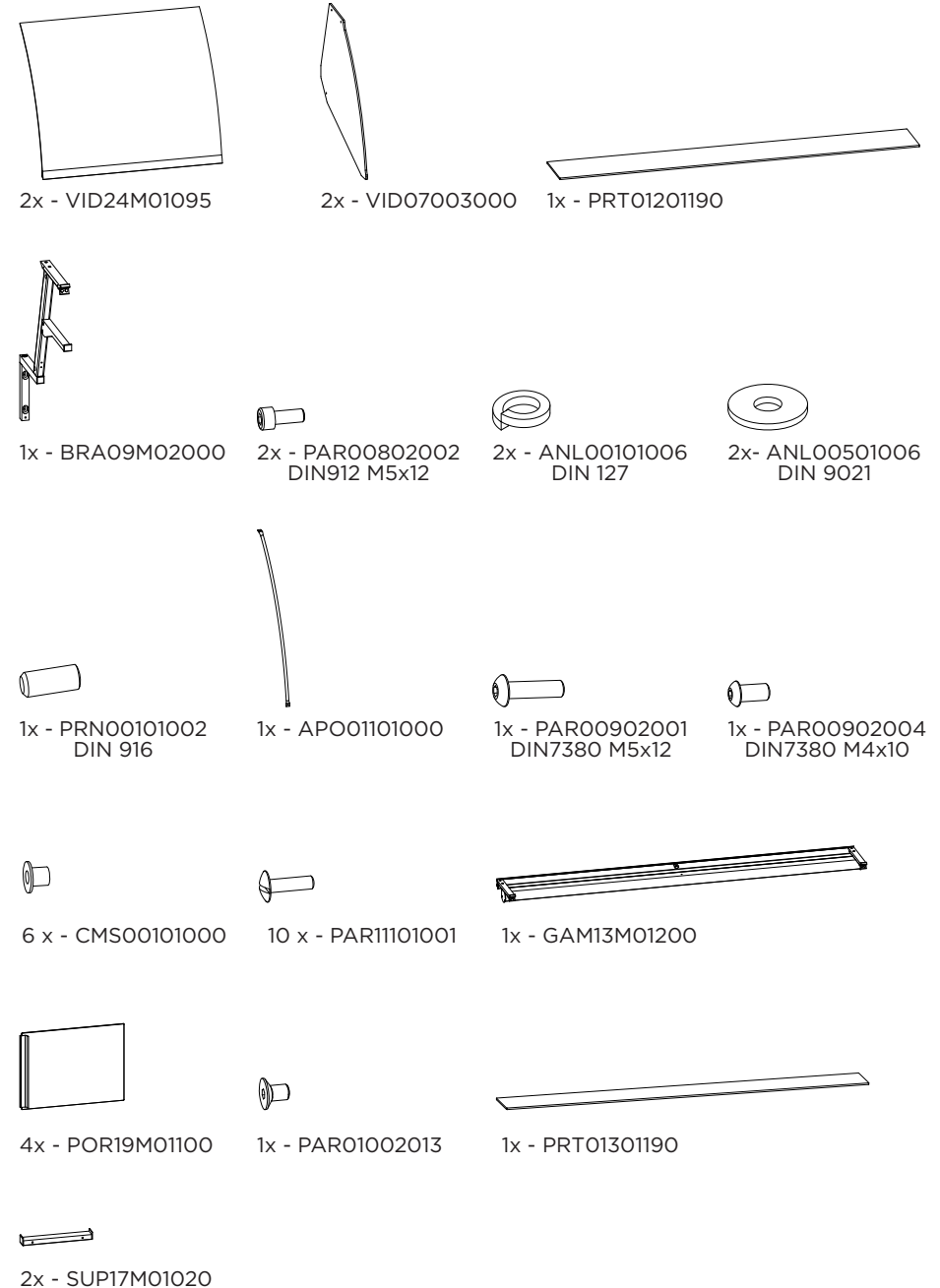

1

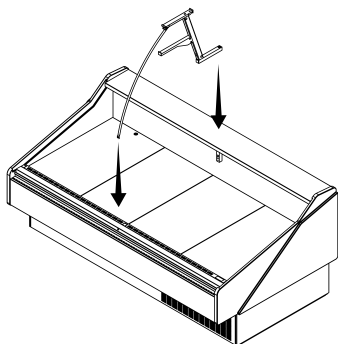

2

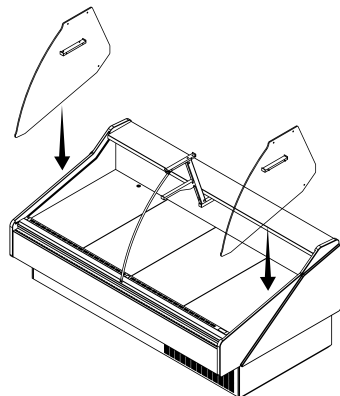

3

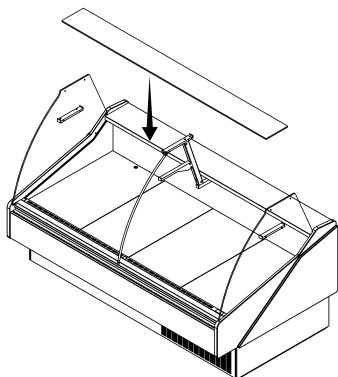

4

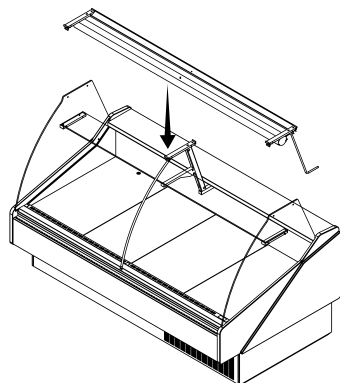

5

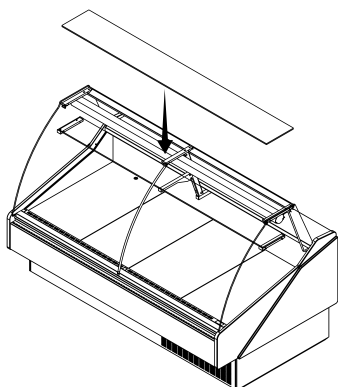

6

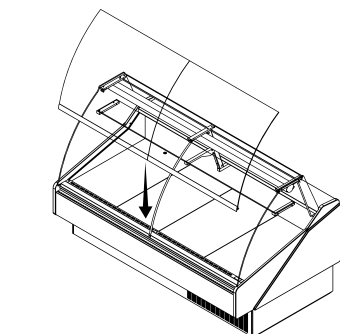

Relay outputs		depending on the model			
		EN 60730-1		UL 873	
model	relay	250 V~	operating cycles	250 V~	operating cycles
IRxxx(E,A) (P,Q,S,U,V,X,Y,Z)xxx	R2 (*)	5(1)A	100000	5 A resistive 1FLA 6 LRA C 300	300000
IRxxx(E,A) (N,R,C,B,A,M,L,T)xxx	R3 (*)	5(1)A	100000	5 A resistive 1FLA 6 LRA C 300	300000
IRxxx(E,A) (N,R,C,B,A,M,L,T)xxx IRxxx(O,L,H) (N,R,C,B,A,M,L,T)xxx	R1,R2 R2,R3 R4 (*)	8 (4)A N.O. 6 (4)A N.C. 2 (2)A N.O./N.C.	100000	8 A resistive 2FLA 12 LRA C300	300000
IRxxx(E,A) (P,Q,S,U,V,X,Y,Z)xxx IRxxx(O,L,H) (N,R,C,B,A,M,L,T)xxx	R1 R1 (*)	12 (2)A N.O./N.C.	100000	12 A resistive 5FLA 30 LRA C300	300000
insulation from very low voltage parts			reinforced 6 mm clearance, 8 mm creepage 3750 V insulation		
insulation between the relay outputs independent			basic 3 mm clearance, 4 mm creepage 1250 V insulation		

SSR outputs Max output voltage : 12 Vdc, Output resistance: 600 Ω, Max output current: 20 mA

(*): Relay not suitable for fluorescent loads (neon lights, ...) that use starters (ballasts) with phase-shift capacitors. Fluorescent lamps with electronic control devices or without phase-shift capacitors can be used, within the operating limits specified for each type of relay.

Connessioni	Type of connection			Cross-section Max. current
Model IRxxxxx0xx IRxxx(E,A)x1xx IRxxxxx2xx IRxxx(E,A)x3xx IRxxx(E,A)x5xx	Relay screw faston removable faston vertical screw	P. Supply screw faston removable faston vertical screw	Probes screw removable removable screw vertical screw	for wires from 12 A 0.5 a 2.5 mm ²

the installer has to provide the correct dimensioning of the power supply and cable connection between the instruments and the loads. Depending on the model, the maximum current in the common terminals 1, 3 or 5 is 12 A. When using the controller at maximum operating temperature and full load, use cables featuring a maximum operating temperature of 105 °C at least.

 Controller must be handled by a qualified technician.

4.4. Electronic controller



Carel - IR33FOAHEO

TECHNICAL SPECIFICATIONS

	Model	Voltage	Power	
Power supply	IRxxxExxxx	230 V~, 50/60 Hz	3 VA, 25 mA~max.	
	IRxxxAXxxx	115V~, 50/60 Hz	3 VA, 50 mA~max.	
	IRxxxHxxxx	115 to 230 V~, 50/60 Hz	6 VA, 50 mA~max.	
	IRxxxLxxxx IRxxx0xxxx	12 to 24V~, 50/60 Hz, 12 to 30 Vdc 12V~, 50/60 Hz, 12 to 18 Vdc	3 VA, 300 mA~/mAdc max. Use only SELV power supply	
Insulation guaranteed by the power supply	IRxxxExxxx IRxxxAXxxx IRxxxHxxxx	insulation in reference to very low voltage parts	reinforced 6mm clearance, 8 mm creepage 3750 V insulation	
		insulation from relay outputs	basic 3mm clearance, 4 mm creepage 1250V insulation	
	IRxxxLxxxx IRxxx0xxxx	insulation in reference to very low voltage parts	externally guaranteed by safety transformer (SELV power supply)	
		insulation from relay outputs	reinforced 6mm clearance, 8 mm creepage 3750 V insulation	
Inputs	S1 (probe 1)	NTC (IRxxx0xxxxx) o NTC e PTC (IRxxx7xxxxx)		
	S2 (probe 2)	NTC (IRxxx0xxxxx) o NTC e PTC (IRxxx7xxxxx)		
	DI 1 S3 (probe 3)	free contact, contact resistance < 10 Ω, closing current 6 mA NTC (IRxxx0xxxxx) o NTC e PTC (IRxxx7xxxxx)		
	DI 2 S4 (probe 4)	free contact, contact resistance < 10 Ω, closing current 6 mA NTC (IRxxx0xxxxx) o NTC e PTC (IRxxx7xxxxx)		
	Maximum distance of probes and digital inputs less than 10 m.			
	Note: during installation keep the power and loads connection separate from probe cables, digital inputs, repeater display and supervisory system.			
Probe type	Std. CAREL NTC	10 kΩ at 25 °C, - 50T90 °C range		
		measurement error:	1 °C in the - 50T50 °C range 3 °C in the - 50T90 °C range	
	NTC high temperature	50 kΩ at 25 °C, - 40T150 °C range		
		measurement error:	1,5 °C in the - 20T115 °C range 4 °C in the - 20T115 °C range	
	PTC std. CAREL (specific model)	985 Ω a 25 °C, range da - 50T150 °C		
		measurement error:	2 °C in the - 50T50 °C range 4 °C in the - 50T150 °C range	

7

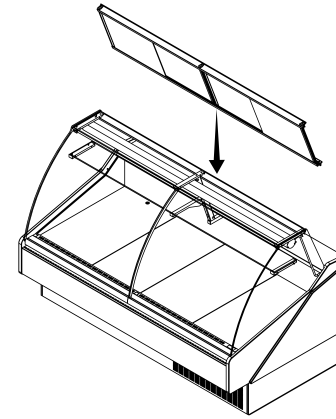

8

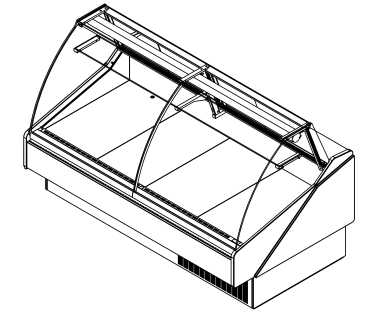

2.3 Check for damage

At the end of production HYDRA KOOL products are carefully inspected. No damaged units are sent out. HYDRA KOOL doesn't take responsibility for damage between factory and client.

Possible damage on the unit must be checked to file a claim near the transportation company.

The unit must be checked in the following points:

- Exterior panels
- Doors
- Shelves
- Glasses
- Paint job
- Door handles
- Base structure

2.4 Control panel and main features

The pictures below, shows the main features and all necessary controls.

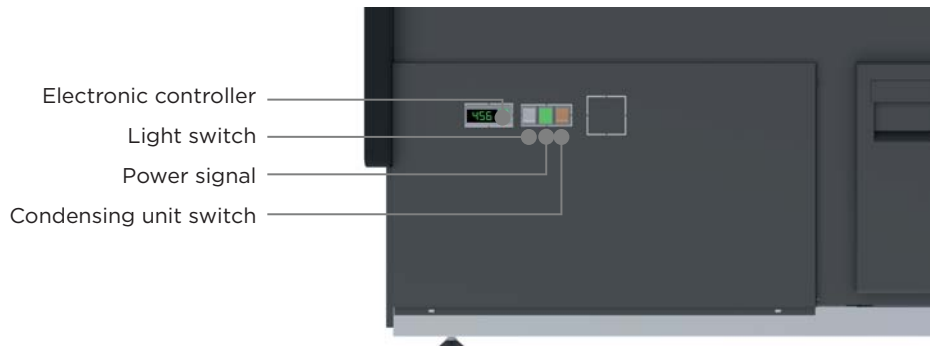
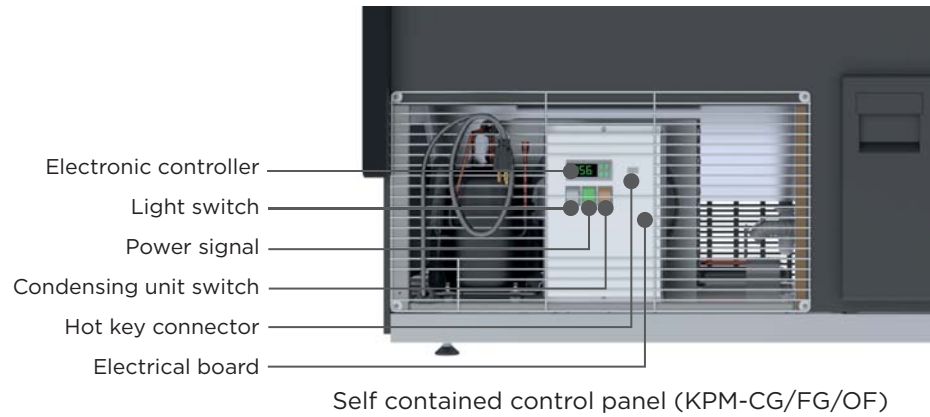

Remote control panel (KPM-CG/FG/OF)

N ^o	Discription
9	Terminal block
12	Evaporator fan
20	Light switch
21	Pilot light
22	Switch
29	Transformer
30	Led lighting

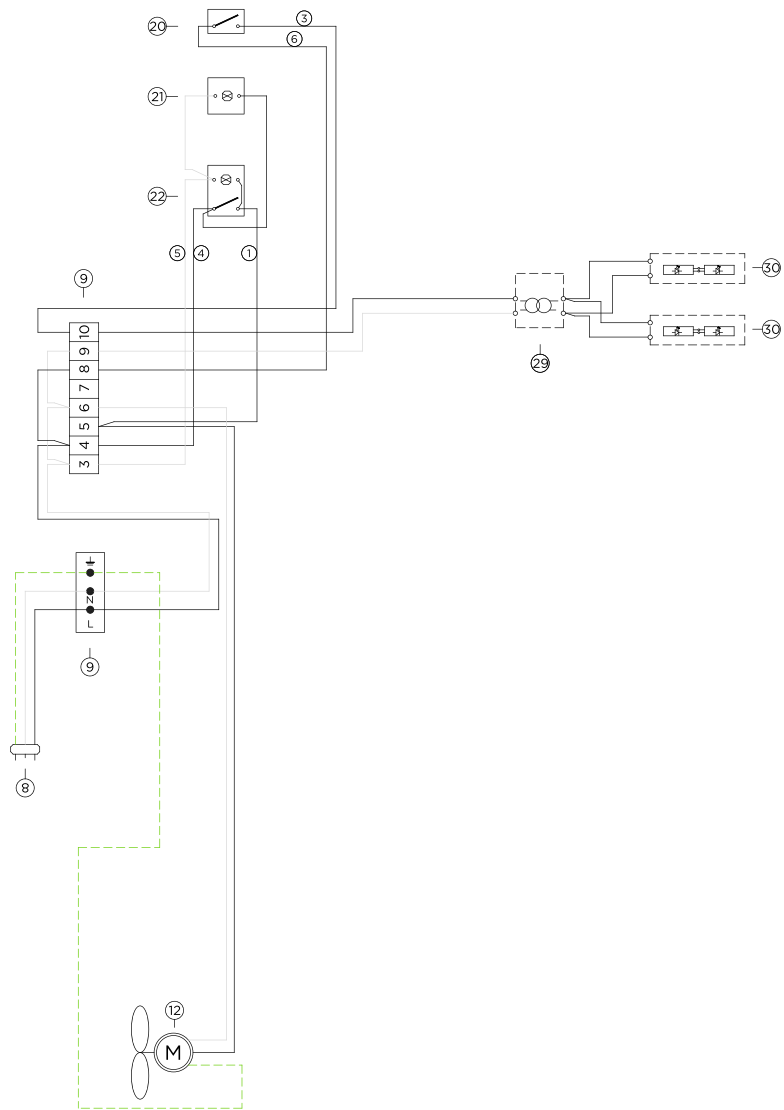

Light switch
Power signal
Power switch



Electrical board



Dry control panel (KPM-CG/FG/OF)

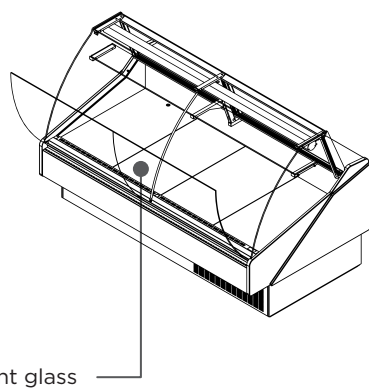
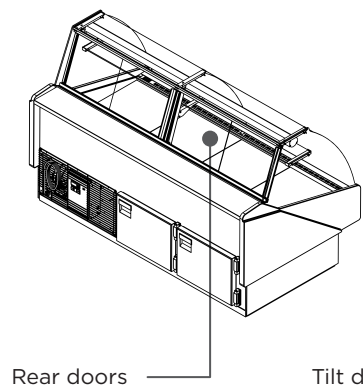
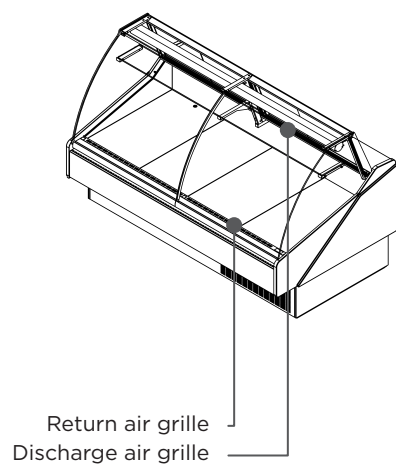
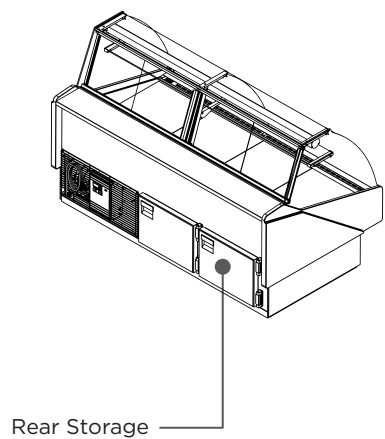

N ^o	Description
6	Controller
7	Temperature probe
9	Terminal block
11	Ground connection
12	Evaporator fan
20	Light switch
21	Pilot light
22	Switch
29	Transformer
30	Led lighting
36	Fan anti-condensation
39	Solenoid valve

2.5 Check serial, model numbers and requested options

Before starting your equipment, check the serial number, model numbers and requested options. This inspection should be made visually in the following items:

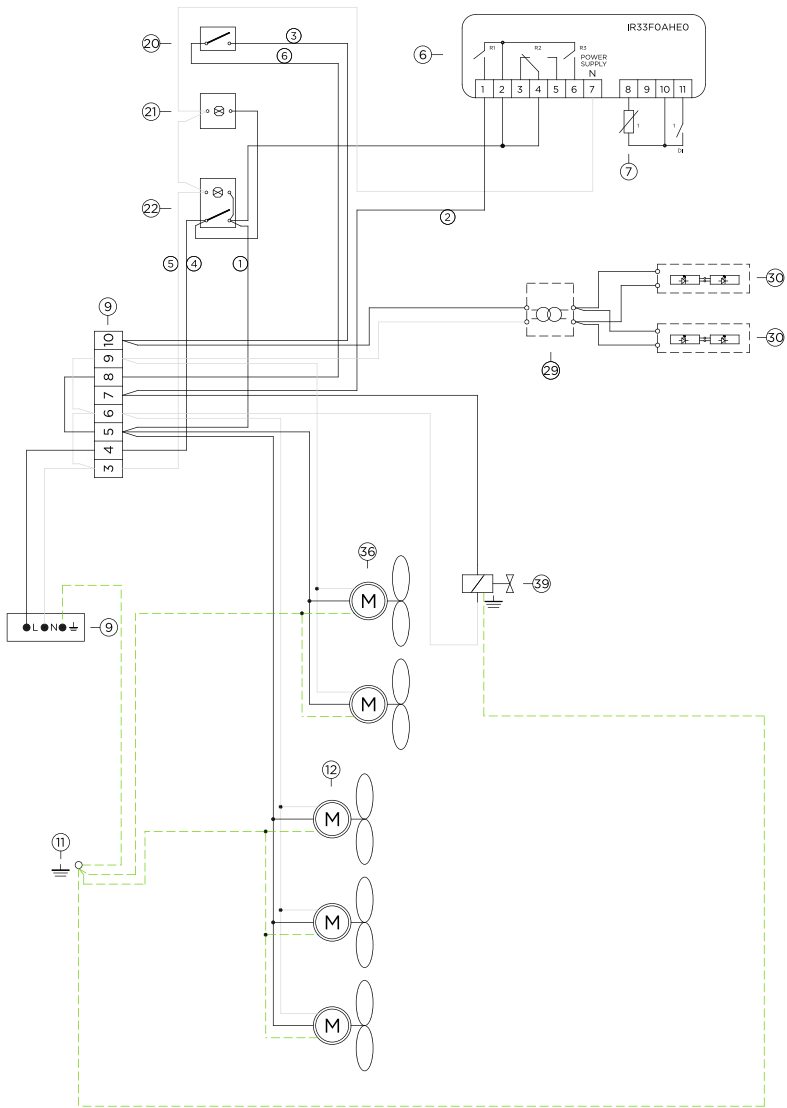

Self contained numbers

MVP GROUP CORP.
 For service, please call: (514) 737-9701
 www.mvpgroupcorp.com

COMMERCIAL REFRIGERATOR CONFORMS TO UL STANDARD 471 AND NSF STD 7 CERTIFIED TO CAN/CSA STD C22.2 NO. 120

ETL US Intertek 4004083

HYDRA KOOL

ETL INTERTEK LISTED Intertek

MADE IN PORTUGAL

120V CIRCUIT

EVAP PAN	DOOR HEATER	LIGTHS	ANTI-S FANS	EVAP FANS	COND FANS	COMP
<input type="checkbox"/>	<input type="checkbox"/>	<input type="checkbox"/>	<input type="checkbox"/>	<input type="checkbox"/>	<input type="checkbox"/>	<input type="checkbox"/>
REF AMOUNT LEFT	REF AMOUNT RIGHT	REF TYPE				
<input type="text"/>	<input type="text"/>	<input type="text"/>				
PSI HIGH SIDE	PSI LOW SIDE					
<input type="text"/>	<input type="text"/>					
TOTAL CASE AMPS <input type="text"/>						

ETL MODEL

CASE FAMILY

SERIAL NO.

DATE MFG

MINI BRANCH
 CIRCUIT AMPACITY
 MAX OVERCURRENT
 PROTECTION AMPS



Remote numbers

MVP GROUP CORP.
 For service, please call: (514) 737-9701
 www.mvpgroupcorp.com

COMMERCIAL REFRIGERATOR CONFORMS TO UL STANDARD 471 AND NSF STD 7 CERTIFIED TO CAN/CSA STD C22.2 NO. 120

ETL US Intertek 4004083

HYDRA KOOL

ETL INTERTEK LISTED Intertek

MADE IN PORTUGAL

120V CIRCUIT

DOOR HEATER	LIGTHS	ANTI-S FANS	EVAP FANS
<input type="checkbox"/>	<input type="checkbox"/>	<input type="checkbox"/>	<input type="checkbox"/>
REF TYPE			
<input type="text"/>			
PSI HIGH SIDE	PSI LOW SIDE		
<input type="text"/>	<input type="text"/>		
TOTAL CASE AMPS <input type="text"/>			

ETL MODEL

CASE FAMILY

SERIAL NO.

DATE MFG

MINI BRANCH
 CIRCUIT AMPACITY
 MAX OVERCURRENT
 PROTECTION AMPS

2.6 Warning/Caution labels

 Before starting, HYDRA KOOL products have caution and warning labels to be respected.

Self contained labels

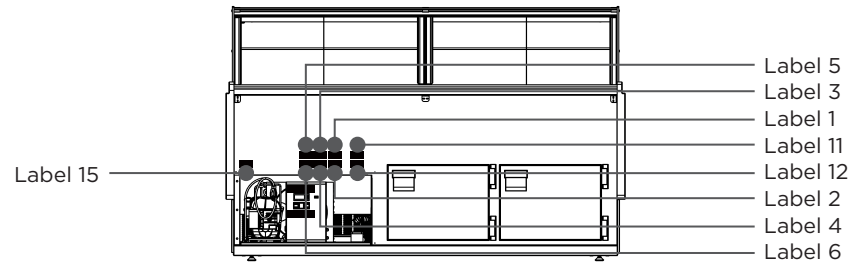

Remote labels

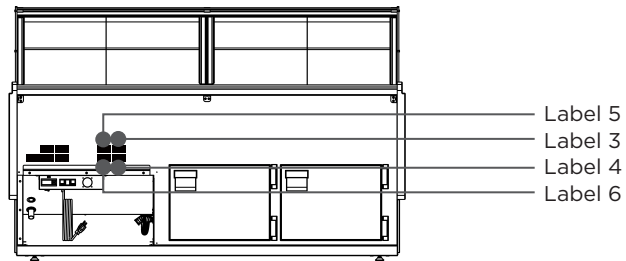

Dry labels

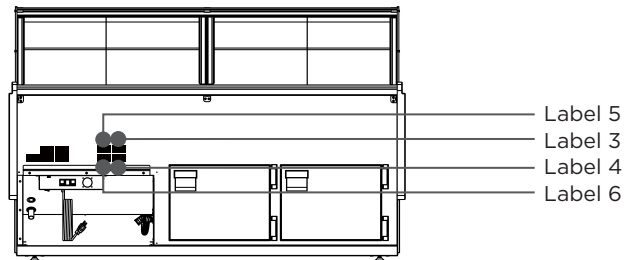

N^o

Discription

1	Compressor
2	Overload
3	Relay
4	Start capacitor
5	Condenser fan
6	Controller
7	Temperature probe
8	Earth two pin plug
9	Terminal block
11	Ground connection
12	Evaporator fan
13	Compressor relay
20	Light switch
21	Pilot light
22	Switch
29	Transformer
30	Led lighting
36	Fan anti-condensation
31	Socket
41	Evaporative condensate pan

4.3. Electrical diagrams

KPM-CG/FG-80-S

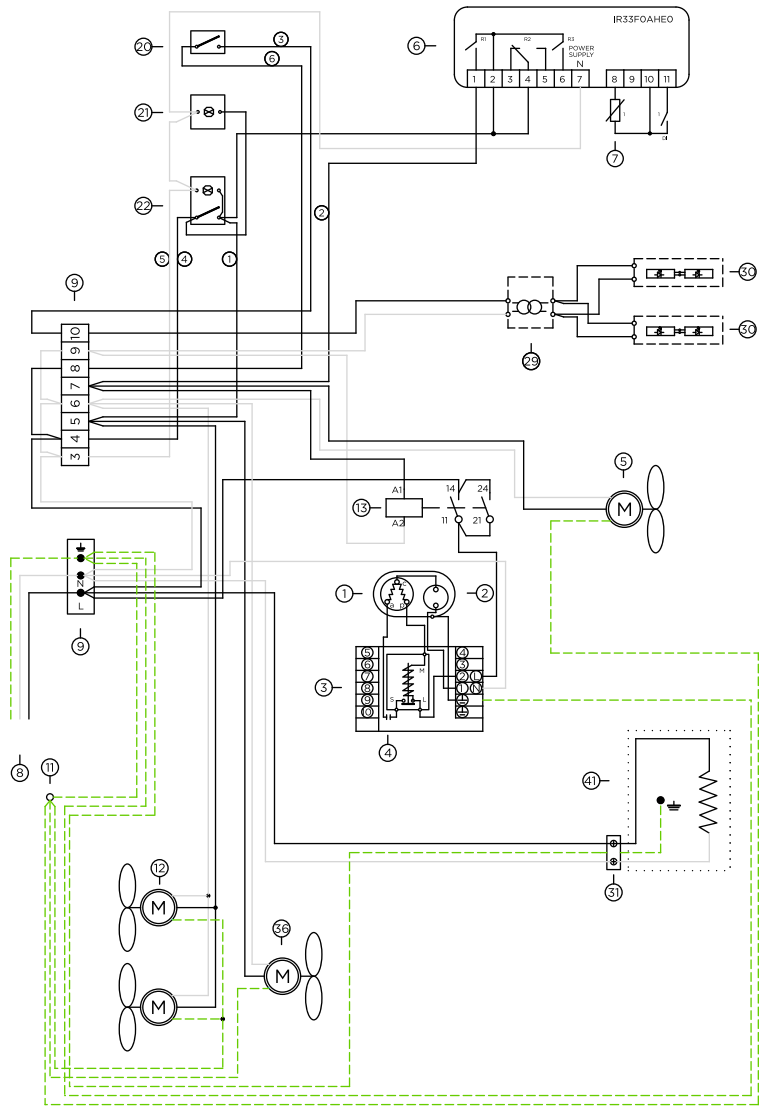

Self contained labels

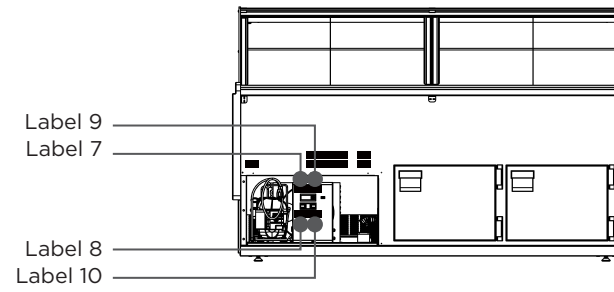

Remote labels

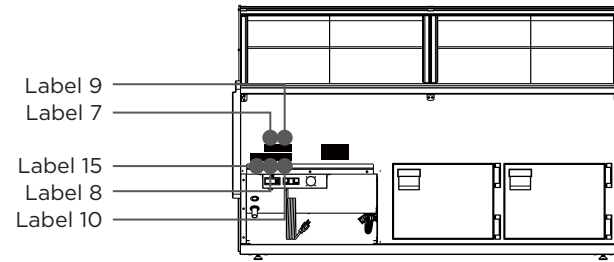

Dry labels

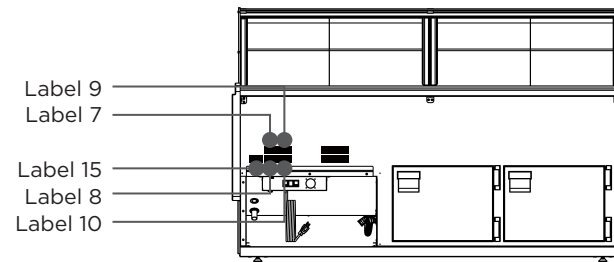

Self contained, Remote and Dry labels (evaporator)

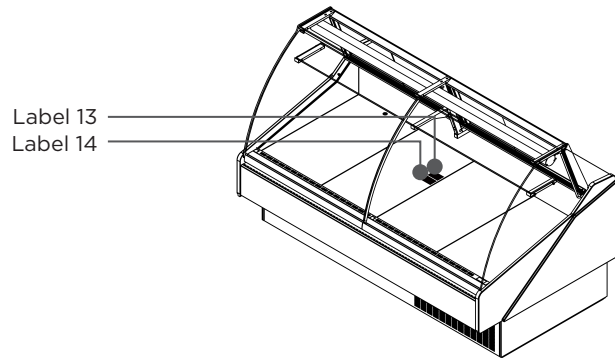

Label 1

CAUTION
MOVING PARTS.
DO NOT OPERATE UNIT
WITH (PART) REMOVED

Label 2

ATTENTION
PIÈCES MOBILES.
NE FAIRE PAS
FONCTIONNER AVEC
DES PIÈCES ENLEVER

Label 3

-NOTE-
THIS A TYPE 1 CASE AND IS
DESIGNED TO OPERATE AT
THE FOLLOWING STORE
CONDITIONS THAT DOES NOT
EXCEED
75 F AND 55% R.H.

Label 4

-NOTE-
CETTE VITRINE TYPE 1 EST
CONÇUE POUR FONCTIONNER
SELON LES CONDITIONS DU
MAGASIN ET NE DOIT
DÉPASSER
75 F AND 55% R.H.

Label 5

-NOTE-
THIS EQUIPMENT IS INTENDED
FOR THE STORAGE
AND DISPLAY OF PACKAGED
FOOD PRODUCTS ONLY

Label 6

-NOTE-
CET EQUIPEMENT EST PREVU
UNIQUEMENT POUR LE
STOCKAGE ET EXPOSITION DE
PRODUITS ALIMENTAIRES
EMBALLER

4.2. Electrical service receptacles (optional)

 Service receptacles are not intended nor suitable for large motors or other external appliances. Only for scales and lighted displays.

Receptacle ampacity

Type	Max. amps
GFCI	2

Model	Compressor F.L.A./L.R.A.	Lights	Fans		Evap pan	Anti condensation system	Total amps (self contained)
			EVP	CND			
KPM-CG/FG-60-S	9,6/49	0,14	0,70	0,45	3,33	0,13	14,35
KPM-CG/FG-80-S	8,9/47	0,18	0,70	0,45	3,33	0,26	14,52
KPM-CG/FG-100-S	16/64	0,24	1,05	0,45	3,33	0,26	14,23
KPM-OF-60-S	9,6/49		0,70	0,45	3,33		14,08
KPM-OF-80-S	8,9/47		0,70	0,45	3,33		14,08
KPM-OF-100-S	16/64		1,05	0,45	3,33		13,73

The data regards to standard options only.

Model	Total amps (remotes only)
KPM-CG/FG-60-R	0,97
KPM-CG/FG-80-R	1,14
KPM-CG/FG-100-R	1,55
KPM-OF-60-R	0,7
KPM-OF-80-R	0,7
KPM-OF-100-R	1,05

Label 7

CAUTION
DISCONNCT ALL POWER.
MAY HAVE MORE THEN
ONE DISCONNCT SWITCH

Label 8

ATTENTION
DEBRANCHER TOUTE
COURANT.
IL PEUT AVOIR PLUS D'UN
INTERRUPTEUR

Label 9

CAUTION
RISK OF ELECTRIC SHOK.
DISCONNECT ALL
POWER BEFORE
SERVICING UNIT

Label 10

ATTENTION
RISQUE DE CHOC
ELECTRIQUE.
AVANT TOUT TRAVAIL
COUPER LE COURANT

Label 11

CAUTION
HOT PARTS.
DO NOT OPERATE UNIT
WITH (PART) REMOVED

Label 12

ATTENTION
PIÈCES BRULANTES.
NE FAIRE PAS
FONCTIONNER AVEC LES
PIÈCES ENLEVER

Label 13

CAUTION
HAZARDOUS MOVING PARTS.
DO NOT OPERATE UNIT
WITH DECK PANS

Label 14

ATTENTION
PIÈCES MOBILES
DANGEREUSES. NE FAIRE
PAS FONCTIONNER AVEC
DES PIÈCES ENLEVER

Label 15

Warning

- This appliance requires a properly grounded dedicated circuit using a NEMA rated wall receptacle do not remove the grounding prong on the plug or the risk of an injury due to shock from the ungrounded electrical service may occur.
- This product can expose an individual to chemicals that have been identified by the state of California to possibly be dangerous leading to various diseases birth defects or other human reproductive system harm. For more information go to www.p65warnings.ca.gov.

2.7 Check your electrical installation

 This equipment is intended to be connected to an outlet with 115V/ 60Hz/ 1 phase.

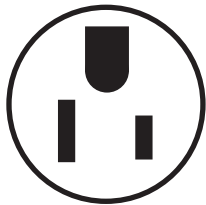

Nema-5-15P

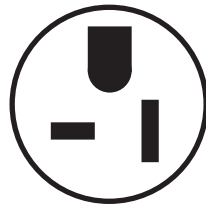

Nema-5-20P

2.8 Electrical, drain and refrigeration connections (remotes only)

 Installation and service must be performed by a qualified technician.

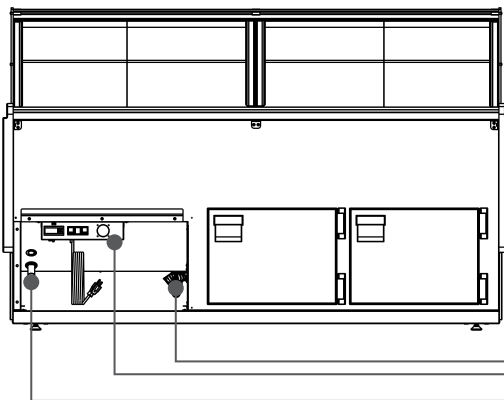

Prepare a drain installation
 All electrical connections must be done from the electrical board
 Equipments for remote installation come with nitrogen under pressure and an easy prep kit (tubing connections needed only) for installation.

All self contained KPM series use the following equipment: capillary tube, finned coil ventilated systems (condenser/evaporator), hermetic compressor, electrical water evaporation system.

Model	Circuit pressure (psig)		Refrigerant and charge (OZ)	Defrost
	High side	Low side		
KPM-CG/FG/OF-60-S	331	174	R 404A 19,40	Automatic 3/day
KPM-CG/FG/OF-80-S	331	174	R 404A 25,39	Automatic 3/day
KPM-CG/FG/OF-100-S	331	174	R 404A 37,74	Automatic 3/day

3.2 Refrigeration loads (remotes only)

 Installation of remote equipment must be done by a qualified technician.

Model	BTU*/h	Expansion valve type	
KPM-CG/SC/FG/SF/OF/SO-60-R	2959	TS2	00
KPM-CG/SC/FG/SF/OF/SO-80-R	3253	TS2	00
KPM-CG/SC/FG/SF/OF/SO-100-R	4372	TS2	00

*values presented are indicative for 14°F evap, and 90°F ambient.

4 Electrical

4.1. Electrical specifications data

 Electrical data can be found on the marking plate.

Standard equipment include led lighting and anti condensation system.

2.9 Joining

For joining follow the steps described.

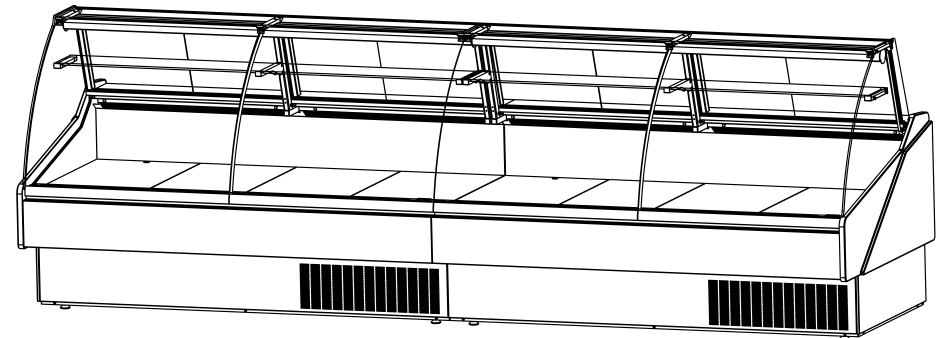
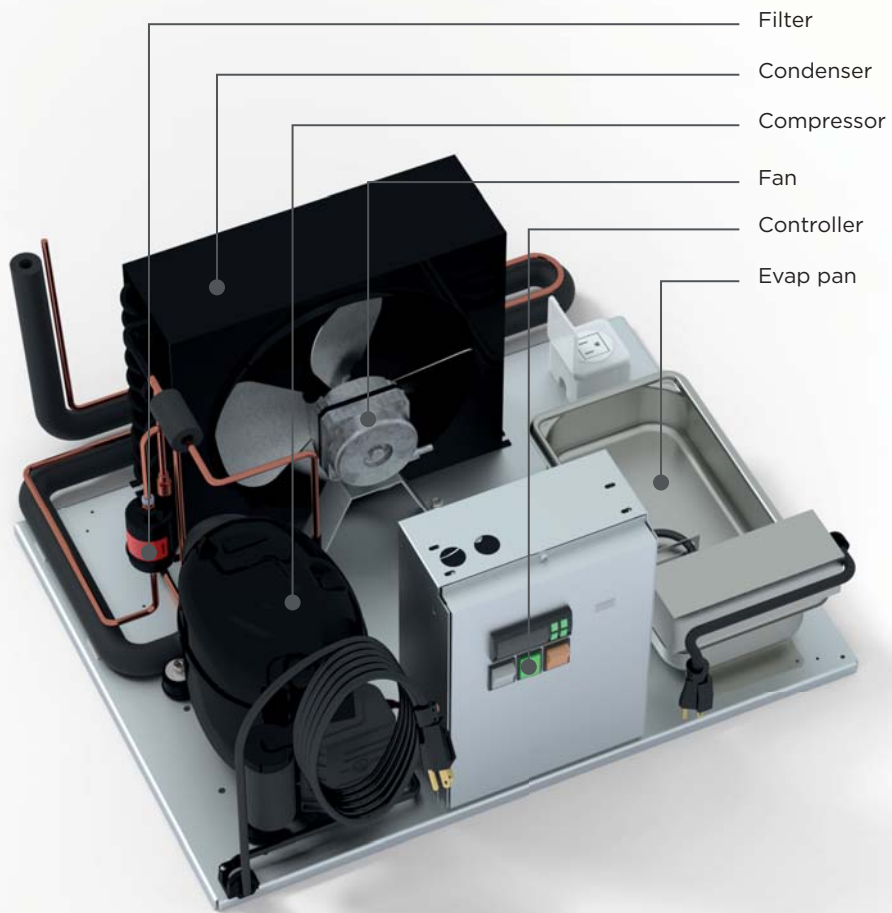



3x - PAR00601013 DIN933 M6x80



2x - PAR00601007 DIN933 M6x20



14x- ANL00501006 DIN9021 M6



5x - PRC00101006 DIN934 M6

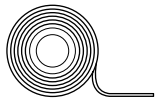

2X FIT00000427 A100 04 (91⁵⁹/₆₄"

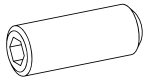

2X PRN00101002 DIN916 M6x16



2x - PAR00902003 DIN 7380 M5x10



2x - PAR00902007 DIN 7380 M5x50



4x - PAR00801102 DIN912 8.8



4x - ANL00101006 DIN 127-B

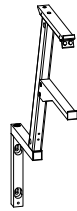

2x - BRA09M02000 VA 71

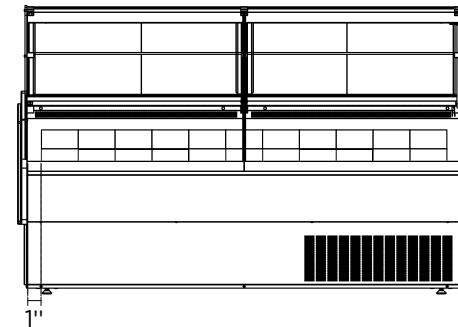
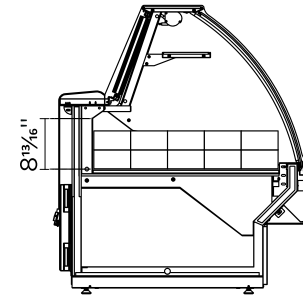

Maintain doors closed after servicing.

9 - If any problem encountered, see troubleshooting or call a qualified technician!

3 Refrigeration

3.1 Self contained refrigeration equipment and defrost

The refrigeration equipment it's laid out in the base of the equipment.

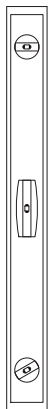

1x

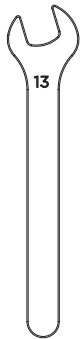

1x

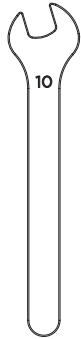

1x

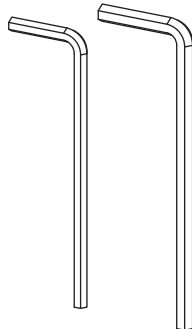

DIN911 - 3/4

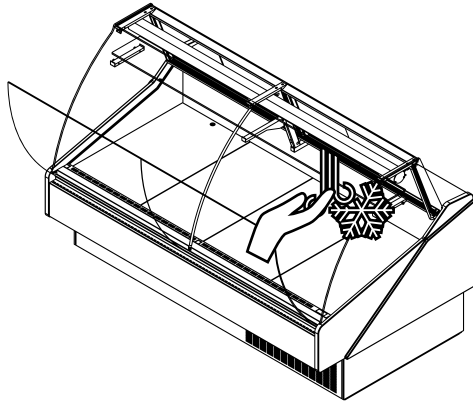

6 - Check air movement in the anti condensation system.

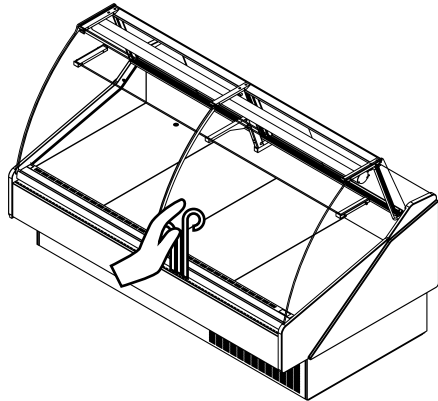
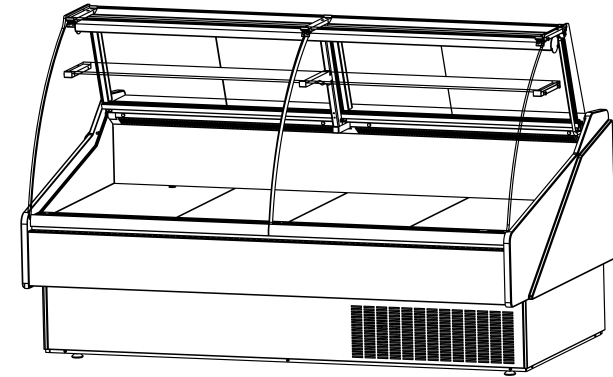

7 - Before loading, leave the equipment working for about 2h.

8 - Load your KPM-Series.

- ⚠ Loading must be done respecting loading limits and weight per square foot mentioned in page xx. This equipment is intended for maintaining temperature, be sure the products are cold, and not ambient temperature.
- ⚠ After loading check for any obstruction in the discharge and return air grilles.

2x KPM-CG

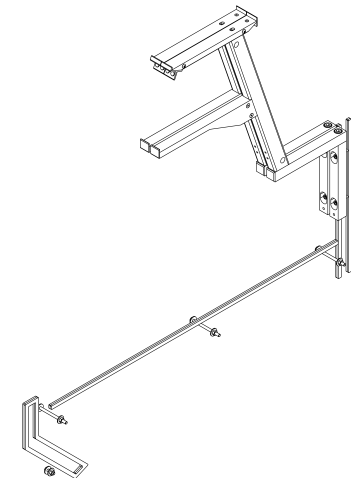

KIT0012U02000

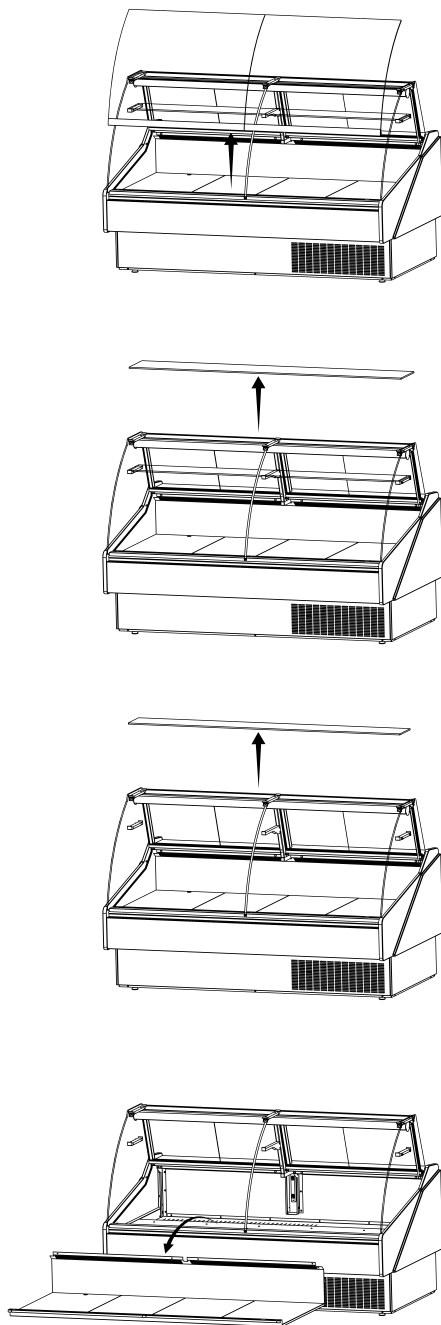

2.10 Plugging and start

To start your equipment follow the steps:

1 - Check for page with parameters inside the manual.

2 - After uncrating and placed the equipment respecting all warnings set in 2.1 chapter, and all switches are set to off position, connect the equipment.

 Make sure you have the correct outlet!

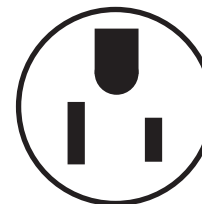

Nema-5-15P

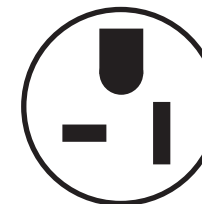

Nema-5-20P

3 - Check lights, using button referenced on chapter 2.4. If not working consult the maintenance chapter.

4 - Turn ON power button referenced in 2.4 chapter.

 Noise will be heard when compressor starts! If compressor doesn't start, call a technician!

5 - Open the door and check for air movement in the discharge air grille.

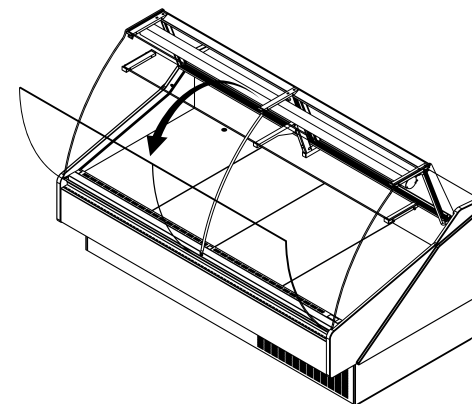

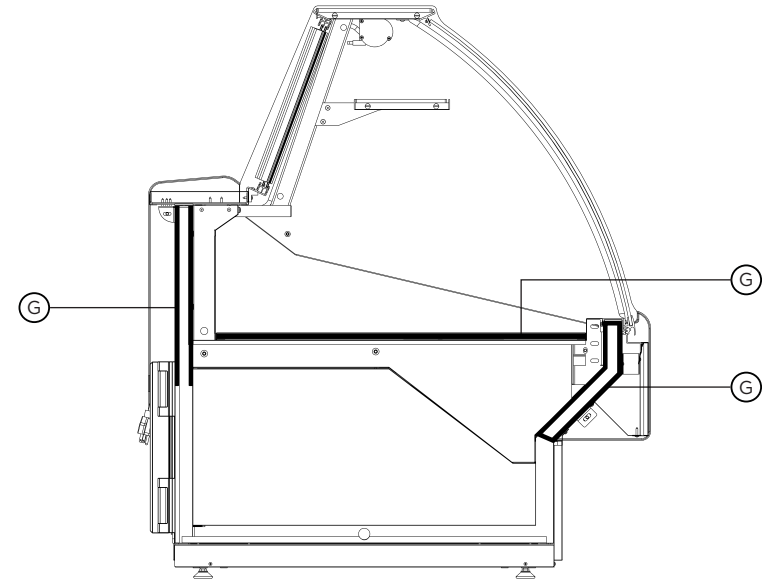
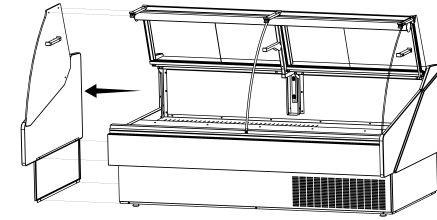
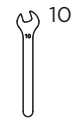
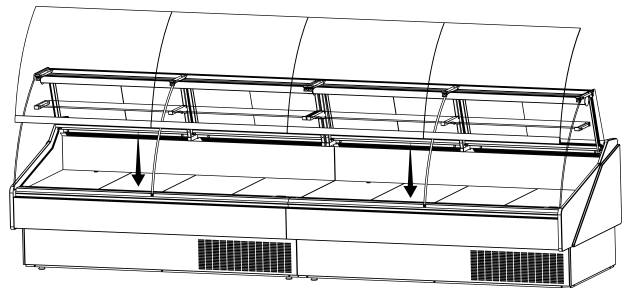
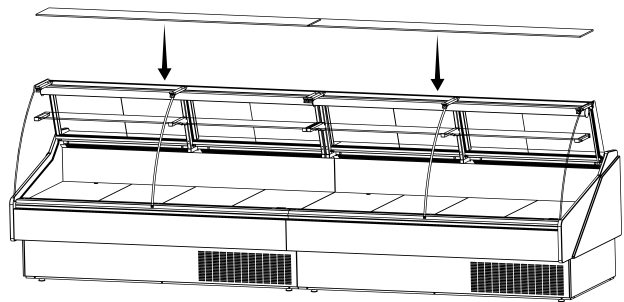
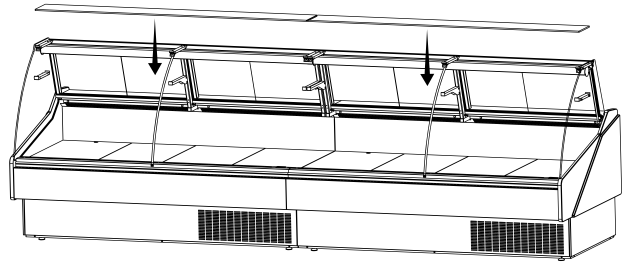
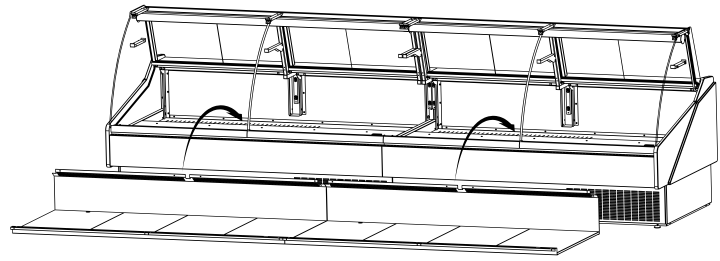
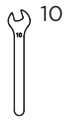

2X - FIT00000427 (91⁴⁹/₆₄")

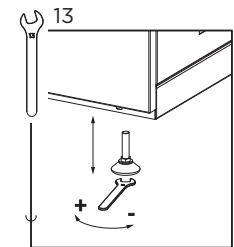
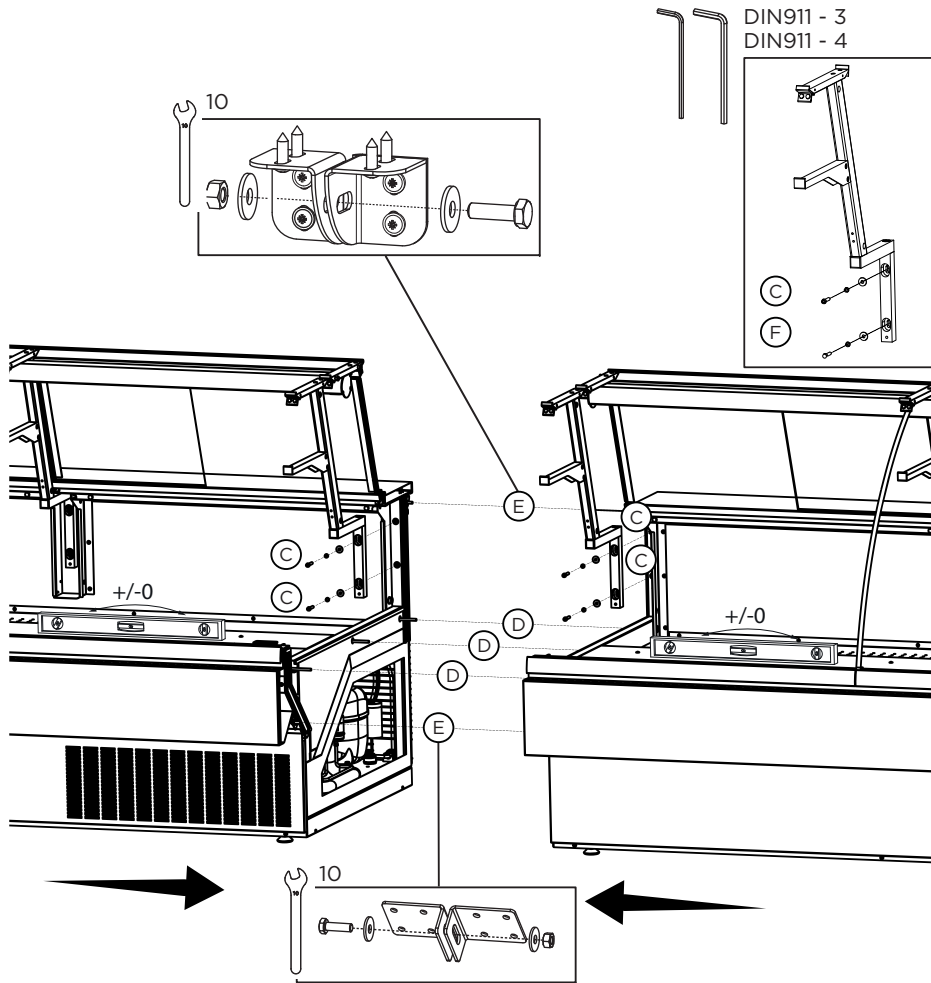

- C** 1x - DIN912 8.8 M6x30
1x - DIN127-B
1x - DIN9021 M6
- D** 1x - DIN933 M6x80
2x - DIN9021 M6
1x - DIN934 M6
- E** 1x - DIN933 M6x20
2x - DIN9021 M6
1x - DIN934 M6
- F** 1x - DIN916 M6x16

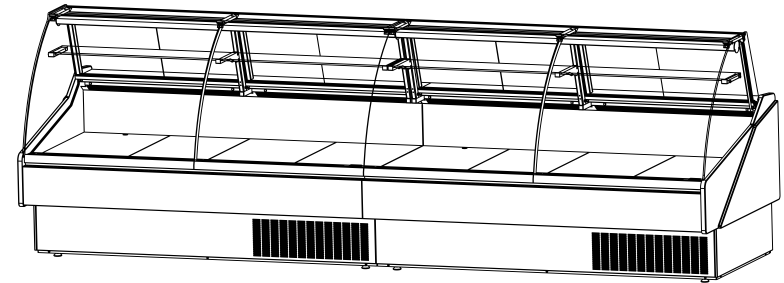
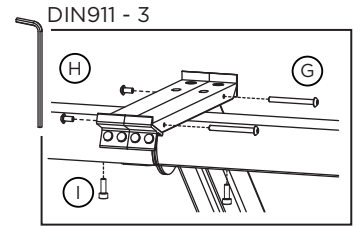

- G** 1x - DIN7380 M5x50
- H** 1x - DIN7380 M5x10
- I** 1x - DIN912 M4x12