

MVP GROUP CORPORATION
www.mvpgroupcorp.com





3560 NW 56th Street
Fort Lauderdale, FL 33309
Tel.: 786.600.4687 / Toll Free: 844.218.8477
Fax.: 786.661.4100

5659 Royalmount Avenue
Montreal, Qc, Canada H4P 2P9
Tel.: 514.737.9701 / Toll Free: 888.275.4538
Fax.: 514.342.3854 / Toll Free: 877.453.8832

sales@mvpgroupcorp.com www.mvpgroupcorp.com

This page has been left blank intentionally.

7 Warranty

12 month warranty for all parts from the invoice date. A new part will be provided free of charge. Defective part must be returned to the manufacturer.

Warranty claims: All claims must include model number, serial number, date of purchase, date of installation and additional information about the supposed defect.

All service work must be authorized by MVP group.

MVP group reserves the right to select the service company.

Loss of food or other damages caused by faulty equipment aren't covered by this warranty.

Warranty does not cover damage when uncrating.

Work made necessary, by lack of maintenance or cleaning are not covered by this warranty.

Warranty does not cover damage or malfunction result of improper use or installation.

Warranty does not cover negligence, misuse and operation on wrong voltage.

Warranty does not apply if the serial number is altered or defaced.

Failure to comply with the instructions in this manual shall avoid warranty.

KFM SERIES

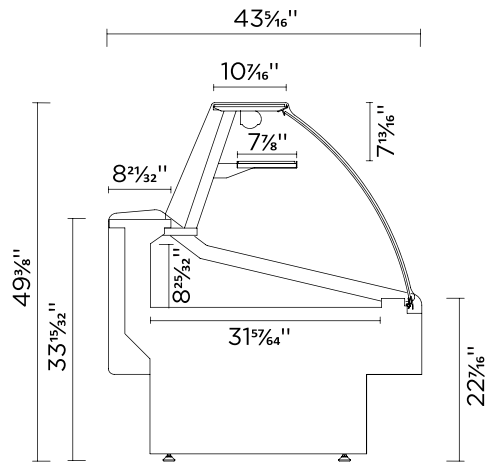

KFM-CG-S(R)(D)



KFM-CG-S(R)(D)

Equipment runs constantly:

Condenser dirty.

Condenser fan malfunction.

Temperature and relative humidity too high.

Starting relay burns out:

Low voltage.

High voltage.

Compressor short cycles.

Incorrect running capacitor.

Incorrect relay.

Head pressure too high:

Unit overcharged.

Air or other non condensable gases in the system.

Clogged condenser.

Defective condenser fan motor.

Unit location too hot.

Restriction in charge line.

Head pressure too low:

Insufficient refrigerant charge.

Leak in the system.

Cold location.

Noisy unit:

Compressor oil charge low.

Fan blade causing vibrations.

Tube rattle.

Loose parts.

Case not leveled.

6.2 Service



This operation must be performed by a qualified technician.



For spare parts, contact your distributor.

6 Troubleshooting/Service

6.1 Troubleshooting

 Service must be performed by a qualified technician.

Doors not closing:

- Check for leveled floor.
- Check for obstruction.
- Remove doors and check the bearings.

Lights not working:

- Check light switch position.
- Check light connections.

Warm case temperature:

- Check for air return grille obstruction.
- Check for air drafts.
- Check store temperature.
- Check for condenser obstruction and cleaning.
- Check for frozen evaporator.
- Check set point.
- Display area is over filled.

Fans not working:

- Check electrical connections.
- Check for any debris.

Case not aligning:

- Check for leveled floor.
- Check instructions for joining.

Display not working:

- Check main power switch position..
- Check electrical connections.

Compressor not starting:

- Disconnect switch open.
- Blown fuse.
- Overload protective tripped.
- Low charge of refrigerant.
- Relay defective.

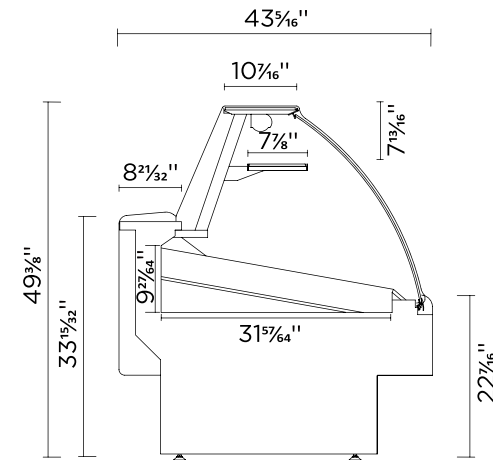

KFM-SC-S(R)



KFM-SC-S(R)

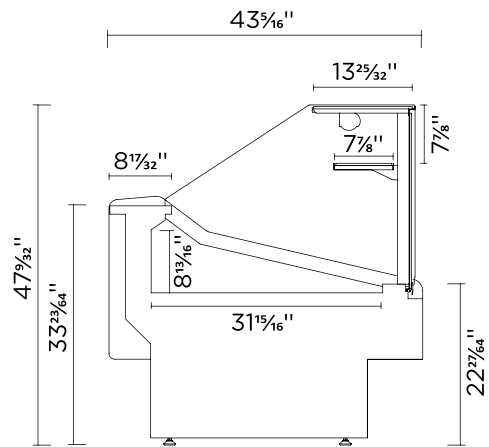

KFM-FG-S(R)(D)





KFM-FG-S(R)(D)

5.11 Drain inspection

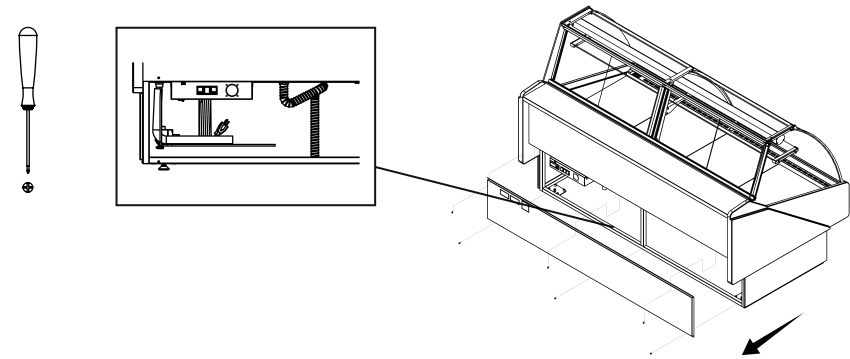
 Check for drain obstruction and correct position every month (Remotes only).



5.12 Glass type conversion model

-  This operation must be performed by a qualified technician.
-  Contact distributor for specific manual to assist in conversion.

To access the evap pan:

- Remove protection grille.
- Unplug the evap pan.
- Relieve the screws and take the evap pan off.
- Clean with soft detergent or warm water.

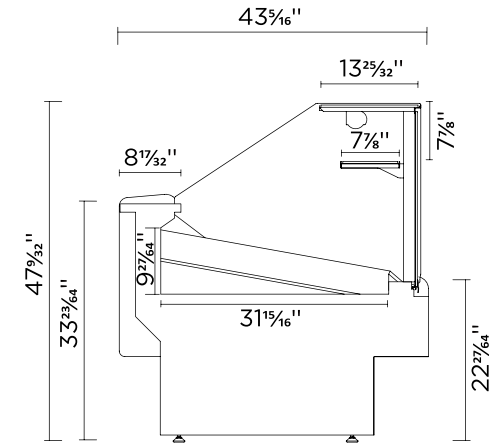
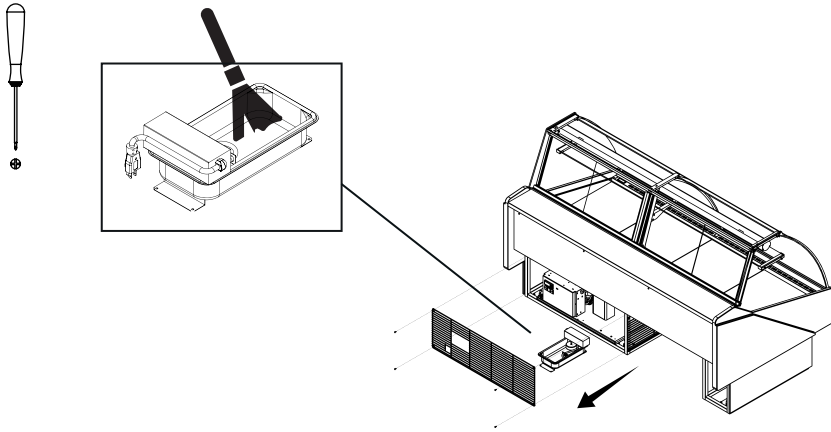

KFM-SF-S(R)

5.10 Fish Pans cleaning

- ⚠ This operation must be performed by a qualified technician.
- ⚠ All operations must be done with the unit disconnected.

To access the fish pan:

- Remove the front glass
- Empty the fish pan
- Clean the pan with adequate detergent and warm water
- Remove all particles from the drain

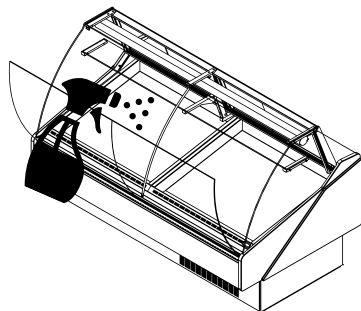

KFM-SF-S(R)

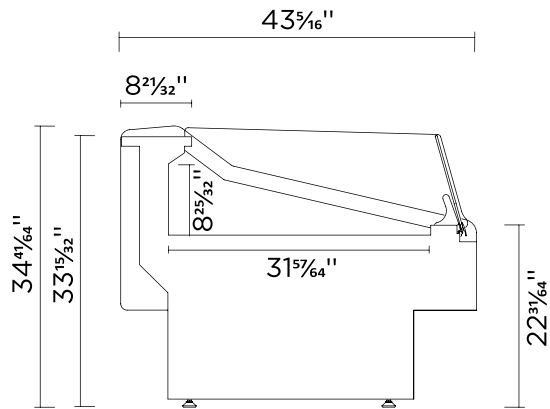

KFM-OF-S(R)(D)



KFM-OF-S(R)(D)

5.8 Evaporator cleaning

- ⚠ This operation must be performed by a qualified technician.
- ⚠ All operations must be done with the unit disconnected.

To access the evaporator:

- Open your unit
- Lift and remove exposition panels
- Use tool for the screws and clean

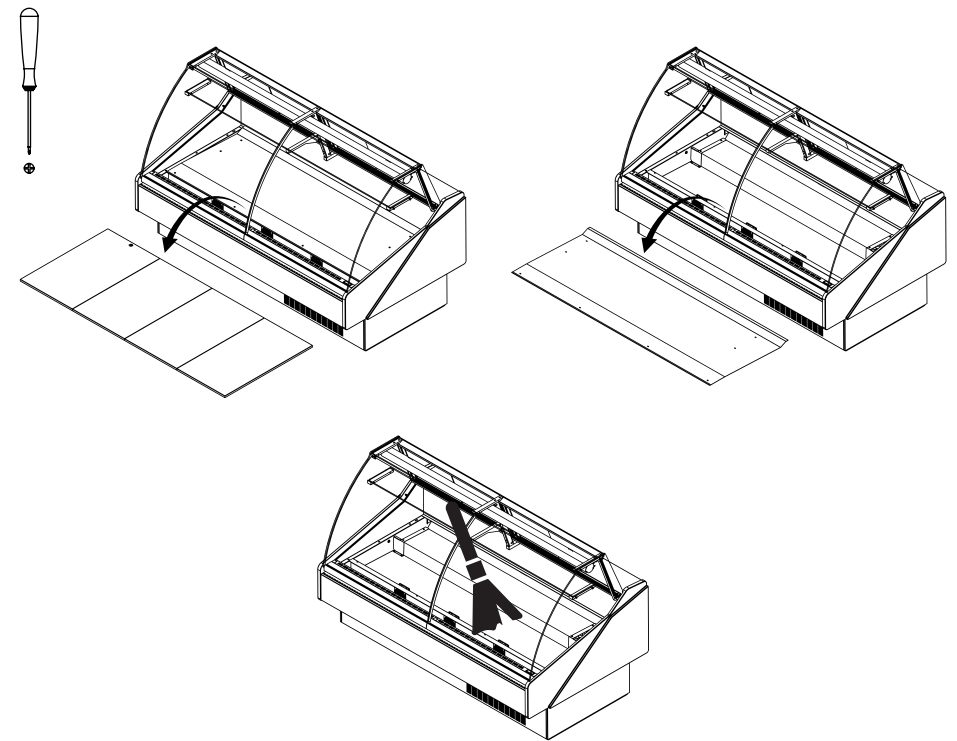

5.9 Evap Pan cleaning

- ⚠ This operation must be performed by a qualified technician.
- ⚠ All operations must be done with the unit disconnected.
- ⚠ Pan can be hot!
- ⚠ This operation must be done weekly.

5.6 Panels and protection grille removal

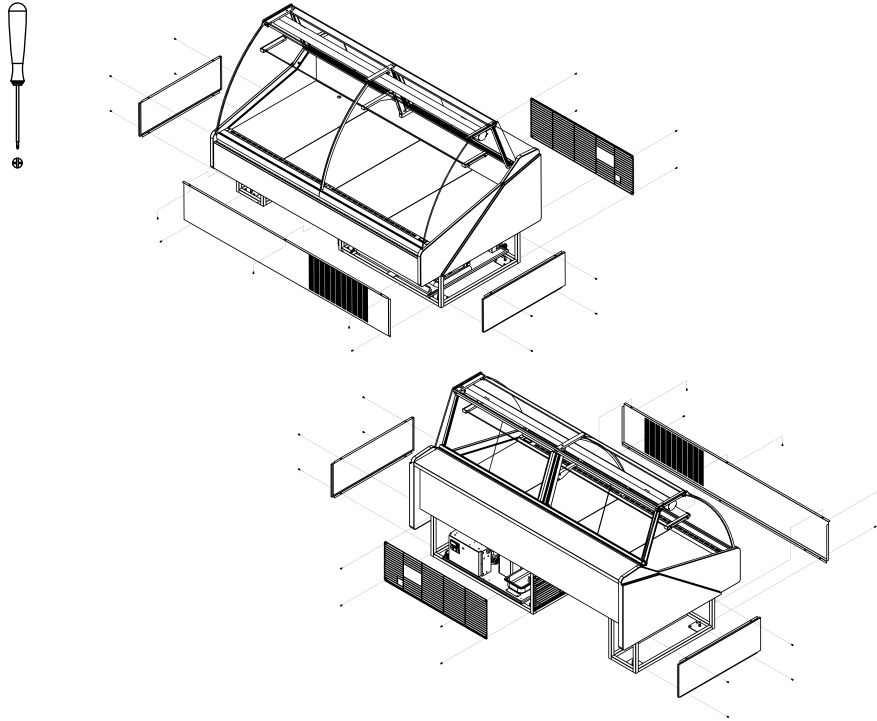

KFM-SO-S(R)

5.7 Condenser cleaning

- ⚠ This operation must be performed by a qualified technician.
- ⚠ All operations must be done with the unit disconnected.

Condenser must be regularly cleaned (every month). Use a brush or vacuum it. To get to the condenser must remove frontal panel.

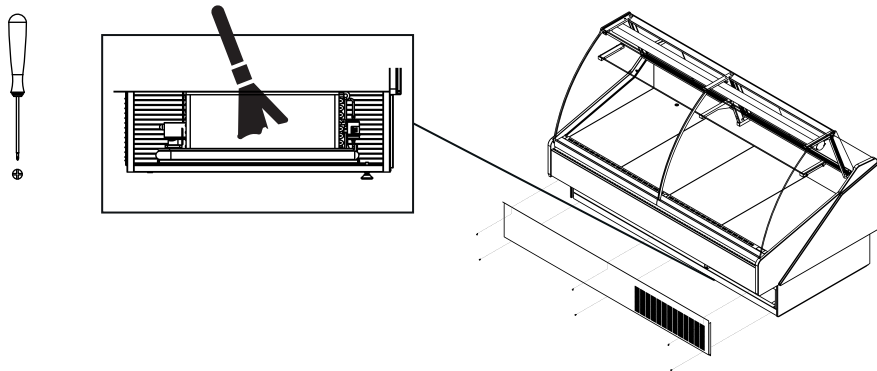

KFM-SO-S(R)

Implantation

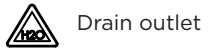

Drain outlet



Electrical board



Refrigeration piping

5.5 Light substitution

To replace lights follow the steps:

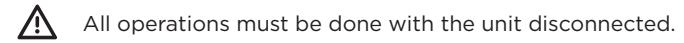

All operations must be done with the unit disconnected.

- Disconnect the light
- Unscrew the light holder and remove the light
- Insert a new light in the same place of the old one, screw the holder connect it
- Screw the light and connect it
- Plug and turn on the light

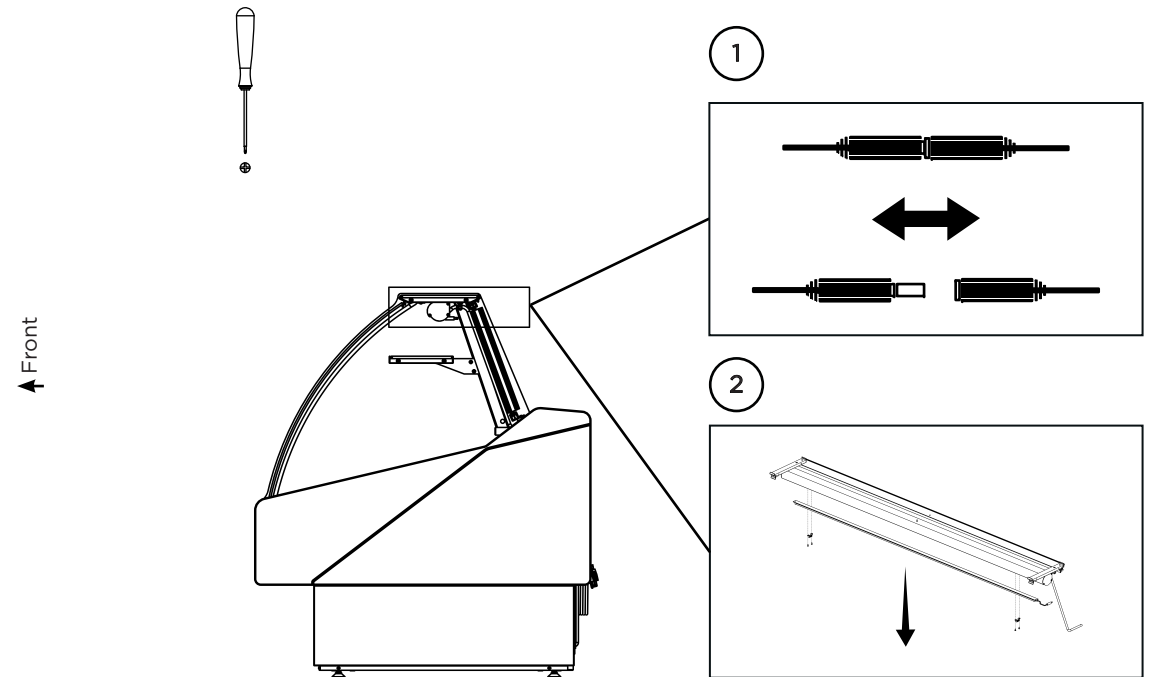

KFM-CG-xx-S

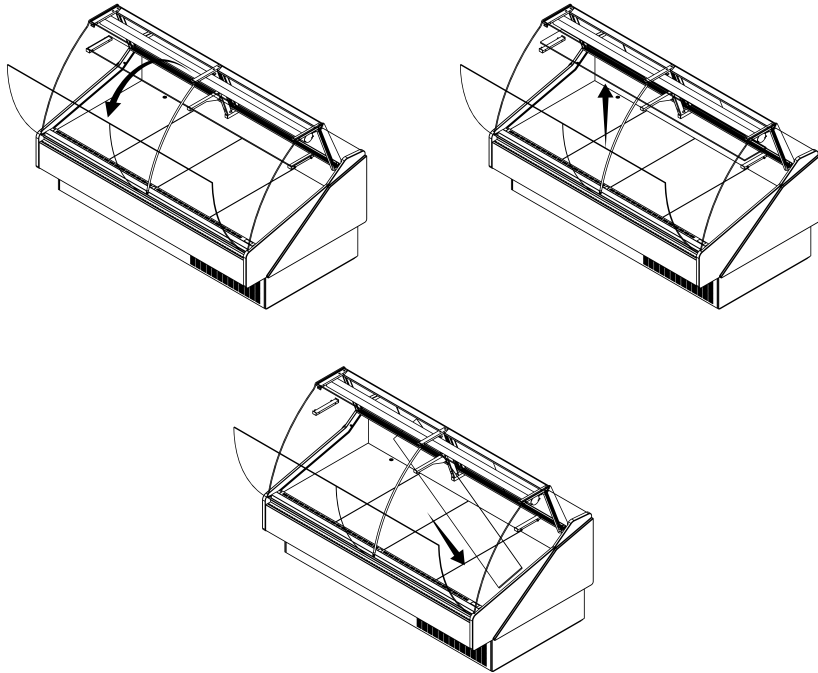

5.4. Back Sliding doors removal



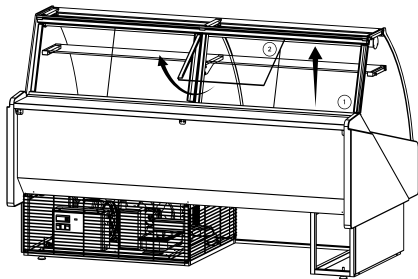

Back sliding doors are easy to take off.
 - Grab door push up and then tilt the bottom towards you.

To put the door back on, just reverse the previous step.



↑ Front

KFM-CG-xx-R

-  Drain outlet
-  Electrical board
-  Refrigeration piping
-  Electrical wiring

For easier cleaning remove the front glass (instructions below).

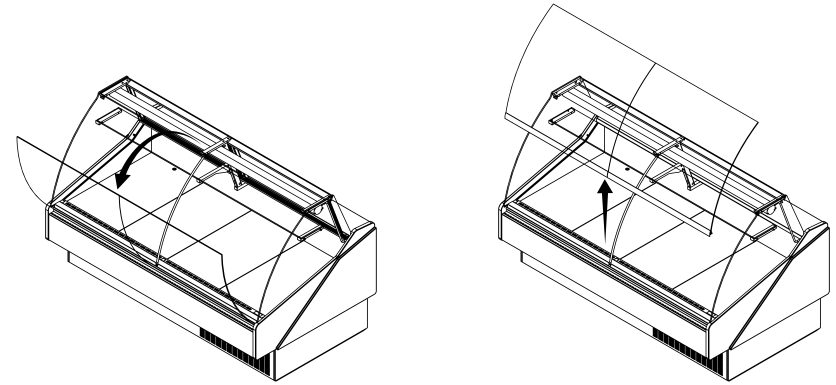

5.2 Interior cleaning

 All operations must be done with the unit disconnected.

Clean surfaces (glass/metal/plastic) with soft detergent or warm water. Do not use abrasive cleanser.

↑ Front

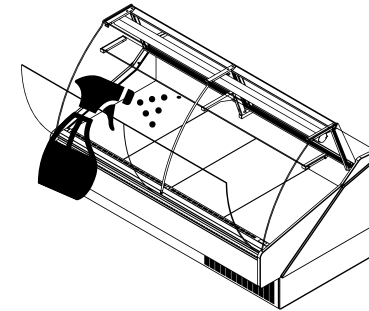

5.3 Shelf removing

 All operations must be done with the unit disconnected.

To remove or adjust shelves take care with light connections.

KFM-FG-xx-S

Main parameters

Symbol	Code	Parameter	Models	UOM	Type	Min	Max	Def.
	/3	Probe display response	MSYF	-	C	0	15	0
	/5	Select °C or °F 0: °C 1: °F	MSYF	flag	C	0	1	0
🔧	/A2	Configuration of probe 2 (S2)	YF	-	C	0	4	2
		0: Probe absent 1: Product probe (display only) 2: Defrost probe 3: Condenser probe 4: Antifreeze probe	MS	-	C	0	4	2
	/c1	Calibration of probe 1	MSYF	°C/°F	C	-20	20	0,0
🌀	St	Temperature set point	MSYF	°C/°F	F	r1	r2	0,0
	rd	Control delta	SYF	°C/°F	F	0,1	20	2,0
🕒	c2	Minimum compressor OFF time	SYF	min	C	0	15	0
❄️	dl	Interval between defrosts	SYF	hours	F	0	250	8
	dP1	Maximum defrost duration, evaporator	SYF	min	F	1	250	30

5 Maintenance

5.1 Exterior cleaning

⚠️ All operations must be done with the unit disconnected.

Clean surfaces (glass/metal/plastic) with soft detergents or warm water. Do not use abrasive cleanser.

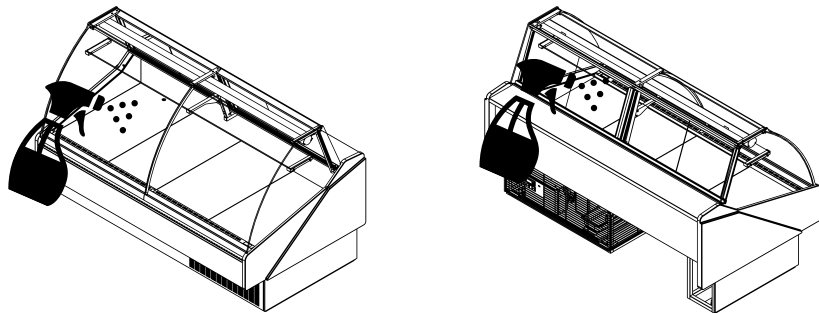

↑ Front

KFM-CG-xx-R

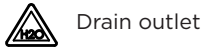

Drain outlet



Electrical board



Refrigeration piping

Signals on the display

The blinking status indicates a request for activation that cannot be implemented until the end of the corresponding delay times.

Icon	Function	ON	OFF	blink	Startup
	COMPRESS.	compressor ON	comp. OFF	compressor request	
	FAN	fan ON	fan OFF	fan request	
	DEFROST	defrost in progress	defrost not required	defrost request	
	AUX	auxiliary output AUX active	auxiliary output AUX not active	anti-sweat heater function active	
	ALARM	delayed external alarm (before the expiry of the time "A7")	no alarm present	alarms in normal operation (eg. high/low temp.) or alarm from ext. digital input immediate or delayed	
	CLOCK	at least one timed defrost has been set	no timed defrost is present	clock alarm	ON if Real-Time Clock present
	LIGHT	auxiliary output LIGHT ACTIVE	auxiliary output LIGHT NOT ACTIVE	anti-sweat heater function active	
	SERVICE		no malfunction	malfunction (eg. EEPROM error or probe fault)	
	HACCP	HACCP function	HACCP function enabled	HACCP alarm (HA and/or HF) not enabled	
	CONTINUOUS CYCLE	enabled	not enabled	request	



Controller must be handled by a qualified technician.

← Front

Buttons on the keypad

Normal operation

Button	Press. the button alone	Pressing together with other buttons	Start-up: if pressed for more than 5 s at start-up, starts the default parameter setting	Automatic address assignment: if pressed for 1 s enters the automatic serial address assigning procedure
	· if pressed for more than 5 s accessed the menu for setting type "F" (frequent) parameters · in the event of alarm: silences the audible alarm (buzzer) and disables the alarm relay	· if pressed for more than 5 s together with the SET button, accesses the menu for setting the type "C" (configuration) or downloading the parameters · if pressed for more than 5 s together with the UP/AUX button resets any alarm with manual reset		
	if pressed for more than 1 s, enables/disables the auxiliary output	· if pressed for more than 5 s together with DOWN/DEF button, enables/disables the continuous cycle operation · if pressed for more than 5 s with SET button, starts the procedure for printing the reports (function available, with management to be implemented) · if pressed for more than 5 s together with PRG/MUTE button, resets any active alarm with manual reset		
	if pressed for more than 5 s, enables/disables a manual defrost	· if pressed for more than 5 s together with UP/AUX button, enables/disables the continuous cycle operation · if pressed for more than 1 s together with SET button, displays a submenu with the HACCP alarm parameters (HA, HAn, HF, HFn)		
	if pressed for more than 1 s, displays and/or set the set point	· if pressed for more than 5 s together with PRG/MUTE button, accesses the menu for setting the type "C" parameters "C" (configuration) or downloading the parameters · if pressed for more than 1 s together with DOWN/DEF button, displays a submenu with the HACCP alarm parameters (HA, HAn, HF, HFn) · if pressed for more than 5 s together with UP/AUX , starts the procedure for printing the report (function available, with management to be implemented)		

KFM-OF-xx-S

Relay outputs	depending on the model				
	model	relay	EN 60730-1 250 V~ operating cycles	UL 873 250 V~ operating cycles	
	IRxxxx(E,A) (P,Q,S,U,V,X,Y,Z)xxx	R2 (*)	5(1)A 100000	5 A resistive 1FLA 6 LRA C 300	300000
	IRxxxx(E,A) (N,R,C,B,A,M,L,T)xxx	R3 (*)	5(1)A 100000	5 A resistive 1FLA 6 LRA C 300	300000
	IRxxxx(E,A) (N,R,C,B,A,M,L,T)xxx IRxxxx(O,L,H) (N,R,C,B,A,M,L,T)xxx	R1,R2 R2,R3 R4 (*)	8 (4)A N.O. 6 (4)A N.C. 2 (2)A N.O./N.C.	8 A resistive 2FLA 12 LRA C300	300000
	IRxxxx(E,A) (P,Q,S,U,V,X,Y,Z)xxx IRxxxx(O,L,H) (N,R,C,B,A,M,L,T)xxx	R1 R1 (*)	12 (2)A N.O./N.C. 100000	12 A resistive 5FLA 30 LRA C300	300000
	insulation from very low voltage parts		reinforced 6 mm clearance, 8 mm creepage 3750 V insulation		
	insulation between the relay outputs independent		basic 3 mm clearance, 4 mm creepage 1250 V insulation		

SSR outputs Max output voltage : 12 Vdc, Output resistance: 600 Ω, Max output current: 20 mA

(*): Relay not suitable for fluorescent loads (neon lights, ...) that use starters (ballasts) with phase-shift capacitors. Fluorescent lamps with electronic control devices or without phase-shift capacitors can be used, within the operating limits specified for each type of relay.



Conessioni	Type of connection			Cross-section Max. current
Model IRxxxxxx0xx IRxxxx(E,A)x1xx IRxxxxxx2xx IRxxxx(E,A)x3xx IRxxxx(E,A)x5xx	Relay screw faston removable faston vertical screw	P. Supply screw faston removable faston vertical screw	Probes screw removable removable screw vertical screw	for wires from 12 A 0.5 a 2.5 mm ²

the installer has to provide the correct dimensioning of the power supply and cable connection between the instruments and the loads. Depending on the model, the maximum current in the common terminals 1, 3 or 5 is 12 A. When using the controller at maximum operating temperature and full load, use cables featuring a maximum operating temperature of 105 °C at least.

 Controller must be handled by a qualified technician.

↑ Front

KFM-OF-xx-R

-  Drain outlet
-  Electrical board
-  Refrigeration piping

4.4. Electronic controller



Carel - IR33FOAHEO

TECHNICAL SPECIFICATIONS

	Model	Voltage	Power	
Power supply	IRxxxxExxxx	230 V~, 50/60 Hz	3 VA, 25 mA~max.	
	IRxxxxAxxxx	115V~, 50/60 Hz	3 VA, 50 mA~max.	
	IRxxxxHxxxx	115 to 230 V~, 50/60 Hz	6 VA, 50 mA~max.	
	IRxxxxLxxxx IRxxxx0xxxx	12 to 24V~, 50/60 Hz, 12 to 30 Vdc 12V~, 50/60 Hz, 12 to 18 Vdc	3 VA, 300 mA~/mAdc max. Use only SELV power supply	
Insulation guaranteed by the power supply	IRxxxxExxxx IRxxxxAxxxx IRxxxxHxxxx	insulation in reference to very low voltage parts	reinforced 6mm clearance, 8 mm creepage 3750 V insulation	
	IRxxxxLxxxx IRxxxx0xxxx	insulation from relay outputs	basic 3mm clearance, 4 mm creepage 1250V insulation	
		insulation in reference to very low voltage parts	externally guaranteed by safety transformer (SELV power supply)	
	IRxxxxLxxxx IRxxxx0xxxx	insulation from relay outputs	reinforced 6mm clearance, 8 mm creepage 3750 V insulation	
Inputs	S1 (probe 1)	NTC (IRxxx0xxxxx) o NTC e PTC (IRxxx7xxxxx)		
	S2 (probe 2)	NTC (IRxxx0xxxxx) o NTC e PTC (IRxxx7xxxxx)		
	DI 1 S3 (probe 3)	free contact, contact resistance < 10 Ω, closing current 6 mA NTC (IRxxx0xxxxx) o NTC e PTC (IRxxx7xxxxx)		
	DI 2 S4 (probe 4)	free contact, contact resistance < 10 Ω, closing current 6 mA NTC (IRxxx0xxxxx) o NTC e PTC (IRxxx7xxxxx)		
	Maximum distance of probes and digital inputs less than 10 m.			
	Note: during installation keep the power and loads connection separate from probe cables, digital inputs, repeater display and supervisory system.			
Probe type	Std. CAREL NTC	10 kΩ at 25 °C, - 50T90 °C range		
		measurement error:	1 °C in the - 50T50 °C range 3 °C in the - 50T90 °C range	
	NTC high temperature	50 kΩ at 25 °C, - 40T150 °C range		
		measurement error:	1,5 °C in the - 20T115 °C range 4 °C in the - 20T115 °C range	
	PTC std. CAREL (specific model)	985 Ω a 25 °C, range da - 50T150 °C		
		measurement error:	2 °C in the - 50T50 °C range 4 °C in the - 50T150 °C range	





↑ Front

KFM-SC-xx-S

N°	Description
9	Terminal block
12	Evaporator fan
20	Light switch
21	Pilot light
22	Switch
29	Transformer
30	Led lighting

↑ Front

KFM-SC-xx-R

-  Drain outlet
-  Electrical board
-  Refrigeration piping
-  Electrical wiring

KFM-CG/FG-40/50/60/80/100/120-D

↑ Front

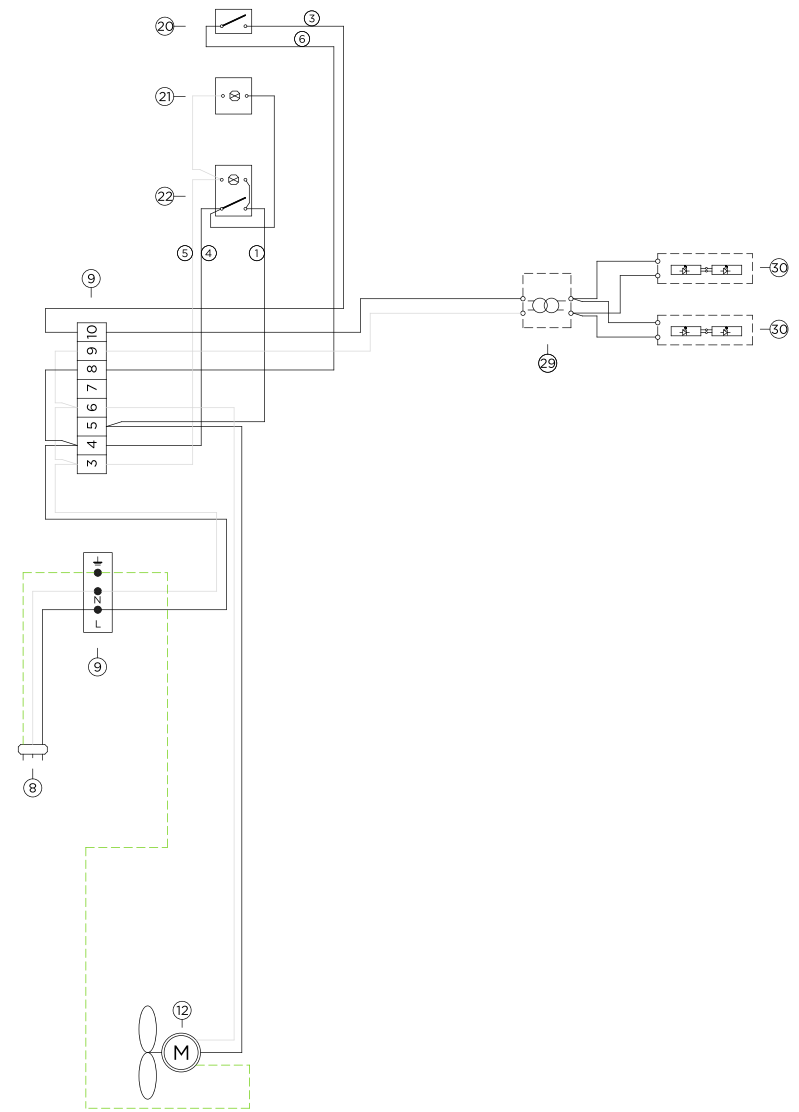





KFM-SF-xx-S

N°	Description
6	Controller
7	Temperature probe
9	Terminal block
11	Ground connection
12	Evaporator fan
20	Light switch
21	Pilot light
22	Switch
29	Transformer
30	Led lighting
36	Fan anti-condensation
39	Solenoid valve

↑ Front

KFM-SF-xx-R

-  Drain outlet
-  Electrical board
-  Refrigeration piping
-  Electrical wiring

KFM-CG/FG-40/50/60/80/100/120-R

↑ Front

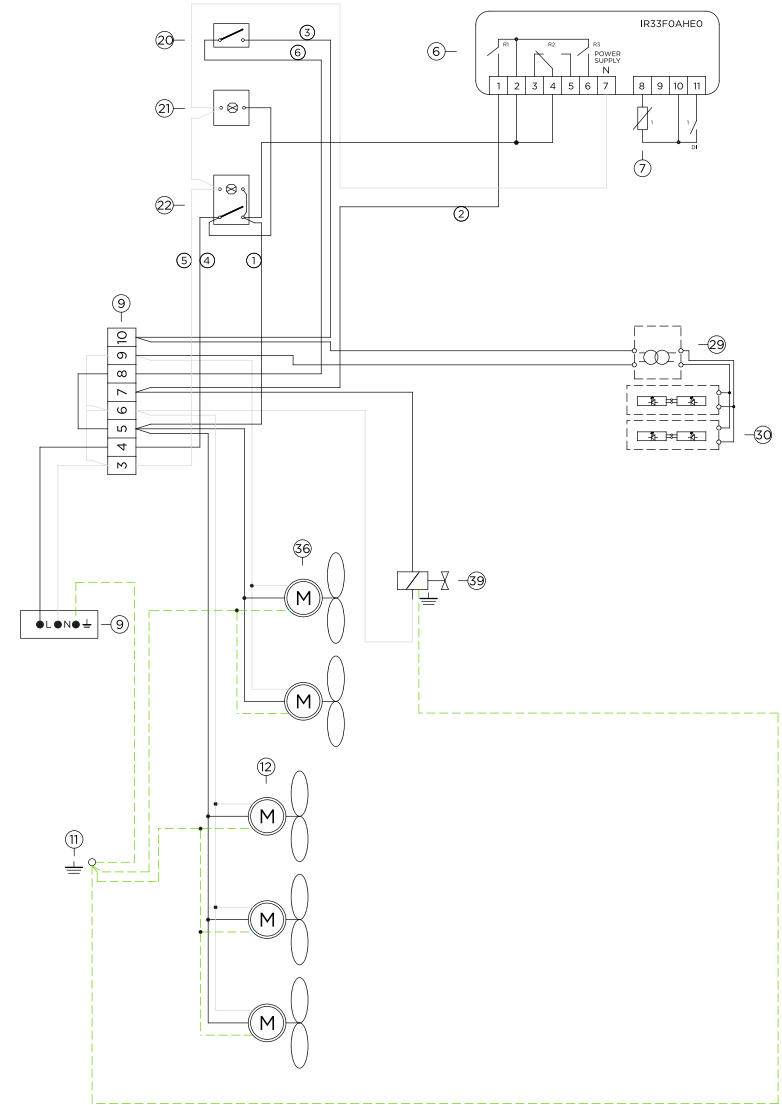

KFM-SO-xx-S

N°	Description
1	Compressor
2	Overload
3	Relay
4	Start capacitor
5	Condenser fan
6	Controller
7	Temperature probe
8	Earth two pin plug
9	Terminal block
11	Ground connection
12	Evaporator fan
13	Compressor relay
20	Light switch
21	Pilot light
22	Switch
29	Transformer
30	Led lighting
36	Fan anti-condensation
31	Socket
41	Evaporative condensate pan

↑ Front

KFM-SO-xx-R

KFM series intended for deli, meat and fish are type 1 equipment - 75°F/55%RH.
 Temperature of deli, meat and fish cases is set for 32°F.

The decks have a 31 lb/ft² loading limit.

Glass shelves are for non refrigerated products only and have a 5,5 lb/ft² loading limit.

KFM-CG/FG-100/120-S

Model	Dimensions (LxDxH in inches)	Service dimensions (LxDxH in inches)	Volume (ft ³)
KFM-CG/SC-40-S(R)	40 ³ / ₁₆ " x 49 ⁹ / ₁₆ " x 61 ¹ / ₁₆ "	40 ³ / ₁₆ " x 49 ⁹ / ₁₆ " x 62 ¹ / ₁₆ "	6,0/2,5
KFM-CG/SC-50-S(R)	52 ³ / ₁₆ " x 49 ⁹ / ₁₆ " x 61 ¹ / ₁₆ "	52 ³ / ₁₆ " x 49 ⁹ / ₁₆ " x 62 ¹ / ₁₆ "	8,0/3,4
KFM-CG/SC-60-S(R)	60 ¹ / ₁₆ " x 49 ⁹ / ₁₆ " x 61 ¹ / ₁₆ "	60 ¹ / ₁₆ " x 49 ⁹ / ₁₆ " x 62 ¹ / ₁₆ "	9,3/4,0
KFM-CG/SC-80-S(R)	77 ⁷ / ₁₆ " x 49 ⁹ / ₁₆ " x 61 ¹ / ₁₆ "	77 ⁷ / ₁₆ " x 49 ⁹ / ₁₆ " x 62 ¹ / ₁₆ "	12,1/5,1
KFM-CG-100-S(R)	101 ³ / ₁₆ " x 49 ⁹ / ₁₆ " x 61 ¹ / ₁₆ "	101 ³ / ₁₆ " x 49 ⁹ / ₁₆ " x 62 ¹ / ₁₆ "	16,0
KFM-CG-120-S(R)	116 ¹⁵ / ₁₆ " x 49 ⁹ / ₁₆ " x 61 ¹ / ₁₆ "	116 ¹⁵ / ₁₆ " x 49 ⁹ / ₁₆ " x 62 ¹ / ₁₆ "	18,6
KFM-FG/SF-40-S(R)	40 ³ / ₁₆ " x 44 ¹ / ₂ " x 61 ¹ / ₁₆ "	40 ³ / ₁₆ " x 44 ¹ / ₂ " x 68 ⁵ / ₈ "	6,0/2,5
KFM-FG/SF-50-S(R)	52 ³ / ₁₆ " x 44 ¹ / ₂ " x 61 ¹ / ₁₆ "	52 ³ / ₁₆ " x 44 ¹ / ₂ " x 68 ⁵ / ₈ "	8,0/3,4
KFM-FG/SF-60-S(R)	60 ¹ / ₁₆ " x 44 ¹ / ₂ " x 61 ¹ / ₁₆ "	60 ¹ / ₁₆ " x 44 ¹ / ₂ " x 68 ⁵ / ₈ "	9,3/4,0
KFM-FG/SF-80-S(R)	77 ⁷ / ₁₆ " x 44 ¹ / ₂ " x 61 ¹ / ₁₆ "	77 ⁷ / ₁₆ " x 44 ¹ / ₂ " x 68 ⁵ / ₈ "	12,1/5,1
KFM-FG-100-S(R)	101 ³ / ₁₆ " x 44 ¹ / ₂ " x 61 ¹ / ₁₆ "	101 ³ / ₁₆ " x 44 ¹ / ₂ " x 68 ⁵ / ₈ "	16,0
KFM-FG-120-S(R)	116 ¹⁵ / ₁₆ " x 44 ¹ / ₂ " x 61 ¹ / ₁₆ "	116 ¹⁵ / ₁₆ " x 44 ¹ / ₂ " x 68 ⁵ / ₈ "	18,6
KFM-OF/SO-40-S(R)	40 ³ / ₁₆ " x 34 ¹¹ / ₁₆ " x 61 ¹ / ₁₆ "	40 ³ / ₁₆ " x 49 ⁹ / ₁₆ " x 61 ¹ / ₁₆ "	6,0/2,5
KFM-OF/SO-50-S(R)	52 ³ / ₁₆ " x 34 ¹¹ / ₁₆ " x 61 ¹ / ₁₆ "	52 ³ / ₁₆ " x 34 ¹¹ / ₁₆ " x 61 ¹ / ₁₆ "	8,0/3,4
KFM-OF/SO-60-S(R)	60 ¹ / ₁₆ " x 34 ¹¹ / ₁₆ " x 61 ¹ / ₁₆ "	60 ¹ / ₁₆ " x 34 ¹¹ / ₁₆ " x 61 ¹ / ₁₆ "	9,3/4,0
KFM-OF/SO-80-S(R)	77 ⁷ / ₁₆ " x 34 ¹¹ / ₁₆ " x 61 ¹ / ₁₆ "	77 ⁷ / ₁₆ " x 34 ¹¹ / ₁₆ " x 61 ¹ / ₁₆ "	12,1/5,1
KFM-OF-100-S(R)	101 ³ / ₁₆ " x 34 ¹¹ / ₁₆ " x 61 ¹ / ₁₆ "	101 ³ / ₁₆ " x 34 ¹¹ / ₁₆ " x 61 ¹ / ₁₆ "	16,0
KFM-OF-120-S(R)	116 ¹⁵ / ₁₆ " x 34 ¹¹ / ₁₆ " x 61 ¹ / ₁₆ "	116 ¹⁵ / ₁₆ " x 34 ¹¹ / ₁₆ " x 61 ¹ / ₁₆ "	18,6

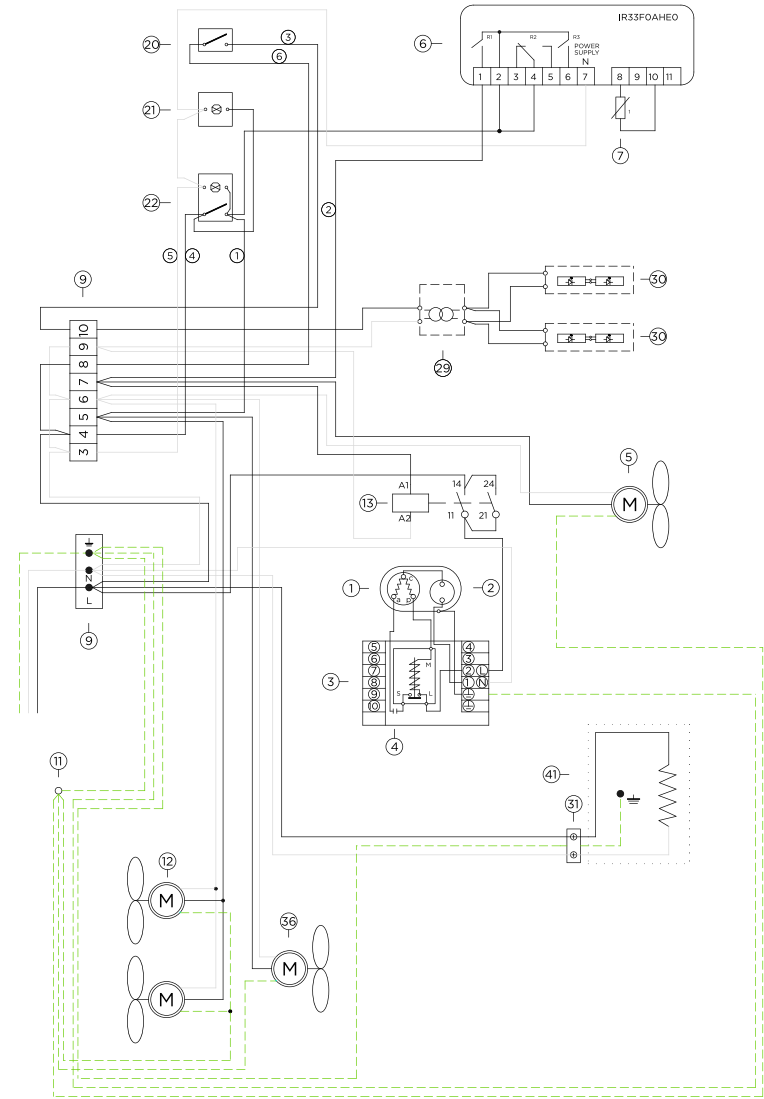















N ^o	Description
1	Compressor
2	Overload
3	Relay
4	Start capacitor
5	Condenser fan
6	Controller
7	Temperature probe
8	Earth two pin plug
9	Terminal block
11	Ground connection
12	Evaporator fan
13	Compressor relay
20	Light switch
21	Pilot light
22	Switch
29	Transformer
30	Led lighting
36	Fan anti-condensation
31	Socket
41	Evaporative condensate pan



2 Getting started with your KFM series

2.1 Location

To your new equipment perform well please respect the following warnings:

-  This is type 1 equipment, intended to work with 75°F / 55%RH.
-  This equipment is intended for maintaining temperature only.
-  Be sure products are not ambient temperature (must be cold)
-  This equipment must be located in an indoor environment.
-  Check for drafts and avoid them.
-  Air movement from ac units shouldn't be directed to the equipment.
-  The equipment must not be directly or indirectly exposed to the sun.
-  Check for rejected heat from another refrigeration units and avoid that.
-  Place the equipment in a levelled floor.
-  Do not obstruct the air way in front of the condenser.
-  Make sure there is a drain preparation (remotes and fish display cases only).
-  Models to be positioned against a wall keep a safe distance of 2³/₈".
-  After servicing always close the doors.
-  Make sure you have a suitable electrical installation.
-  This equipment should be handled by a qualified technician.

2.2 Uncrating

-  All operations must be done carefully.
-  All plastic protective films must be removed before using the equipment for the first time.

1

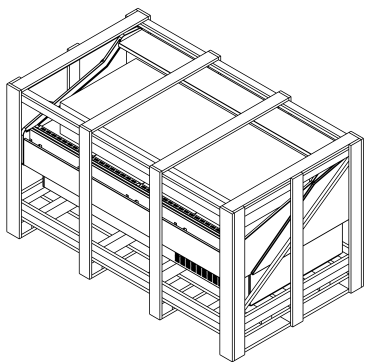

2

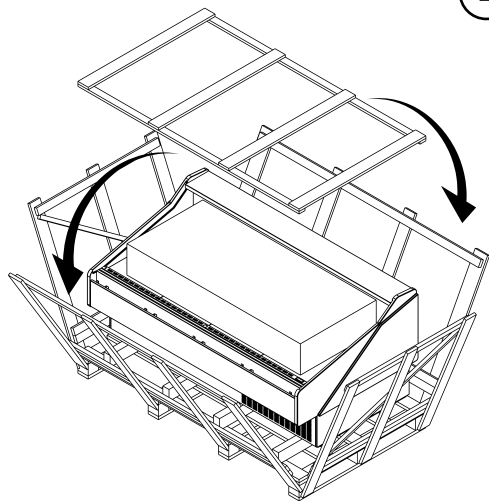

3

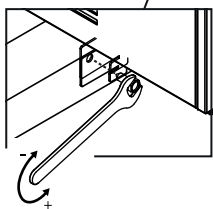
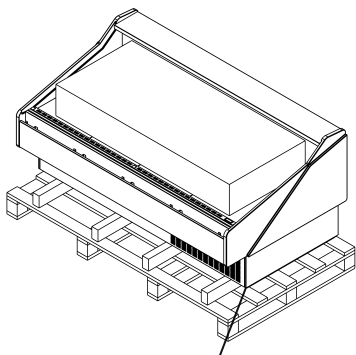

4

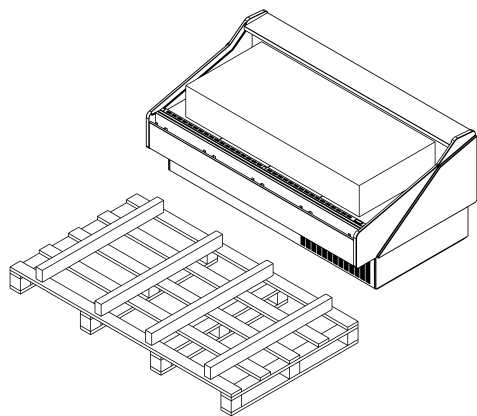

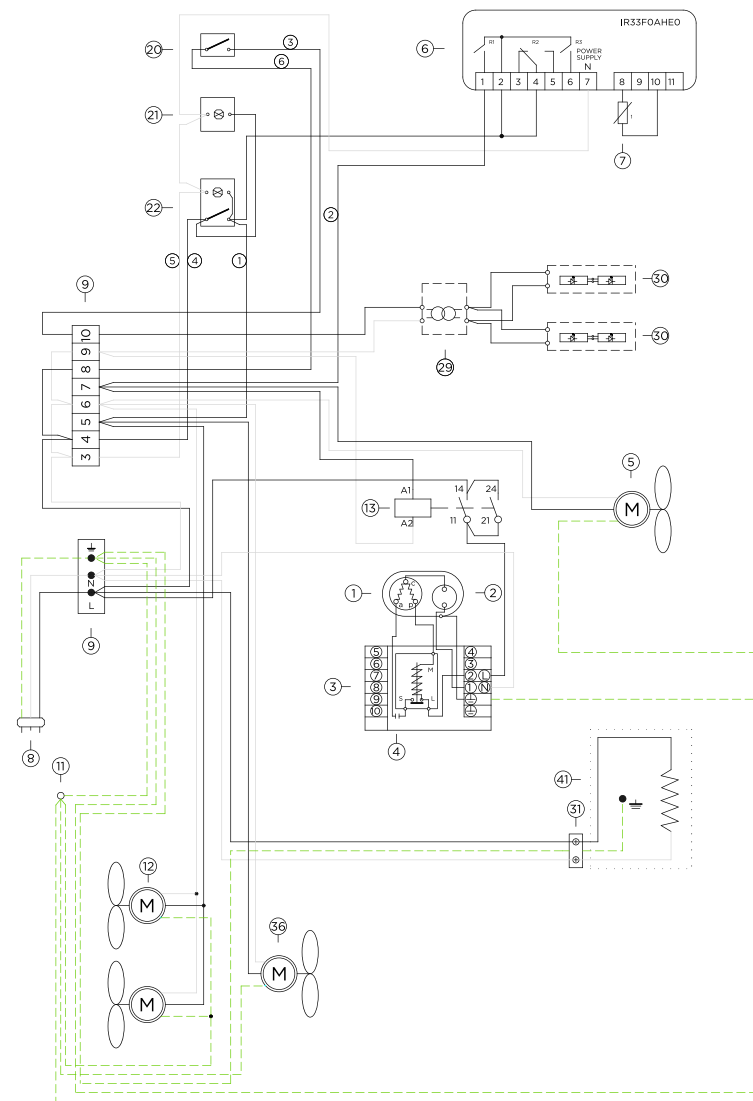

4.3. Electrical diagrams

KFM-CG/FG-40/50/60/80-S



4.2. Electrical service receptacles (optional)

-  Service receptacles are not intended nor suitable for large motors or other external appliances. Only for scales and lighted displays.
-  All operations must be done with the unit disconnected

Receptacle ampacity

Type	Max. amps
GFCI	2

2.2.1 Front and sides assemblies

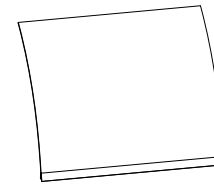

2x - VID24M01095



2x - VID07003000



1x - PRT01201190



1x - BRA09M02000



2x - PAR00802002
DIN912 M5x12



2x - ANL00101006
DIN 127



2x - ANL00501006
DIN 9021



1x - PRN00101002
DIN 916



1x - APO01101000



1x - PAR00902001
DIN7380 M5x12



1x - PAR00902004
DIN7380 M4x10



6 x - CMS00101000



10 x - PAR11101001



1x - GAM13M01200

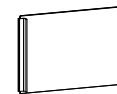

4x - POR19M01100



1x - PAR01002013



1x - PRT01301190



2x - SUP17M01020

1

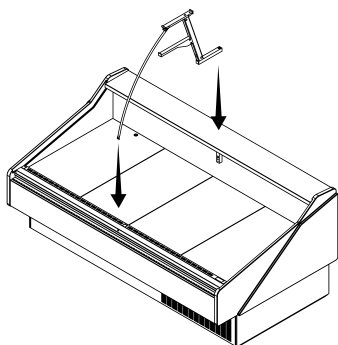

2

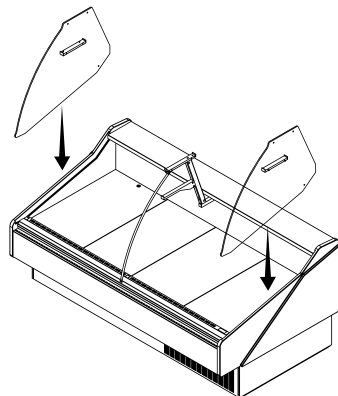

3

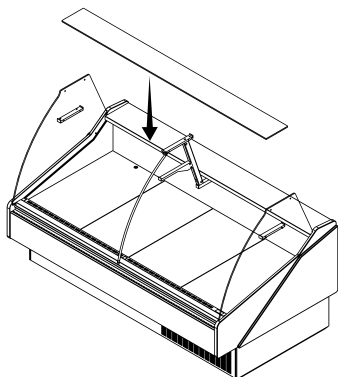

4

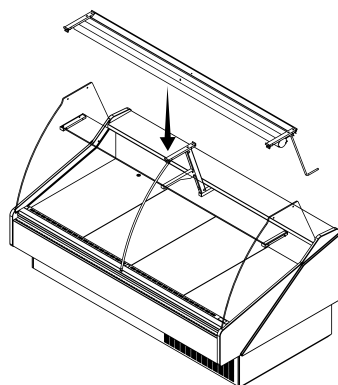

5

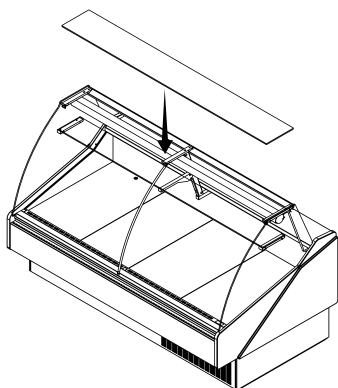

6

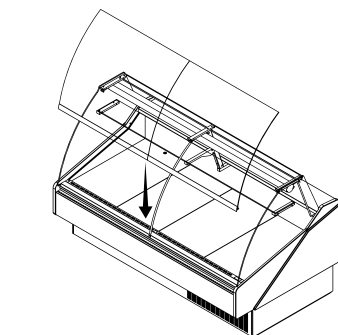

115V/60Hz/1 phase

Model	Compressor F.L.A./L.R.A.	Lights	Fans		Evap pan	Anti condensation system FANS	Total amps (self contained)
			EVP	CND			
KFM-SO-60-S	9,6/49		0,30	0,45			13,68
KFM-SO-80-S	8,9/47		0,30	0,90			13,43
KFM-SO-100-S	16/64		0,40	0,90			20,63
KFM-SO-120-S	16/64		0,50	0,90			20,73

The data regards to standard options only.

Model	Total amps (remotes only)	Model	Total amps (remotes only)
KFM-CG/FG-40-R	0,5	KFM-OF-60-R	0,3
KFM-CG/FG-50-R	0,51	KFM-OF-80-R	0,3
KFM-CG/FG-60-R	0,63	KFM-OF-100-R	0,4
KFM-CG/FG-80-R	0,78	KFM-OF-120-R	0,5
KFM-CG/FG-100-R	0,91	KFM-SO-40-R	0,2
KFM-CG/FG-120-R	1,16	KFM-SO-50-R	0,2
KFM-SC/SF-40-R	0,5	KFM-SO-60-R	0,3
KFM-SC/SF-50-R	0,51	KFM-SO-80-R	0,3
KFM-SC/SF-60-R	0,63	KFM-SO-100-R	0,4
KFM-SC/SF-80-R	0,78	KFM-SO-120-R	0,5
KFM-SC/SF-100-R	0,91		
KFM-SC/SF-120-R	1,16		
KFM-OF-40-R	0,2		
KFM-OF-50-R	0,2		

4 Electrical

4.1. Electrical specifications data

 Electrical data can be found on the marking plate.

Standard equipment includes led lighting and anti condensation system.

115V/60Hz/1 phase

Model	Compressor F.L.A./L.R.A.	Lights	Fans		Evap pan	Anti condensation system FANS	Total amps (self contained)
			EVP	CND			
			KFM-CG/FG-40-S	8,4/43			
KFM-CG/FG-50-S	9,6/49	0,05	0,20	0,45	3,33	0,26	13,89
KFM-CG/FG-60-S	9,6/49	0,07	0,30	0,45	3,33	0,26	14,01
KFM-CG/FG-80-S	8,9/47	0,09	0,30	0,90	3,33	0,39	13,91
KFM-CG/FG-100-S	16/64	0,12	0,40	0,90	3,33	0,39	21,14
KFM-CG/FG-120-S	16/64	0,14	0,50	0,90	3,33	0,52	21,39
KFM-SC/SF-40-S	8,4/43	0,04	0,20	0,45		0,26	12,68
KFM-SC/SF-50-S	9,6/49	0,05	0,20	0,45		0,26	13,89
KFM-SC/SF-60-S	9,6/49	0,07	0,30	0,45		0,26	14,01
KFM-SC/SF-80-S	8,9/47	0,09	0,30	0,90		0,39	13,91
KFM-SC/SF-100-S	16/64	0,12	0,40	0,90		0,39	21,14
KFM-SC/SF-120-S	16/64	0,14	0,50	0,90		0,52	21,39
KFM-OF-40-S	8,4/43		0,20	0,45	3,33		12,38
KFM-OF-50-S	9,6/49		0,20	0,45	3,33		13,58
KFM-OF-60-S	9,6/49		0,30	0,45	3,33		13,68
KFM-OF-80-S	8,9/47		0,30	0,90	3,33		13,43
KFM-OF-100-S	16/64		0,40	0,90	3,33		20,63
KFM-OF-120-S	16/64		0,50	0,90	3,33		20,73
KFM-SO-40-S	8,4/43		0,20	0,45			12,38
KFM-SO-50-S	9,6/49		0,20	0,45			13,58

The data regards to standard options only.

7

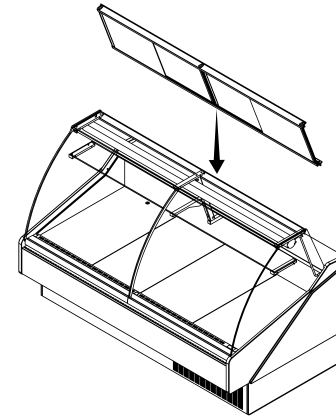

8

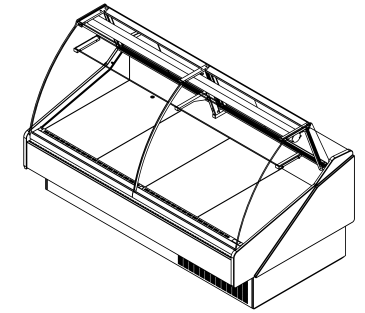

2.3 Check for damage

At the end of production HYDRA KOOL products are carefully inspected. No damaged units are sent out.

HYDRA KOOL doesn't take responsibility for damage between factory and client.

Possible damage on the unit must be checked to file a claim near the transportation company.

The unit must be checked in the following points:

- Exterior panels
- Doors
- Shelves
- Glasses
- Paint job
- Door handles
- Base structure
- Fish pans

2.4 Control panel and main features

The pictures below, shows the main features and all necessary controls.

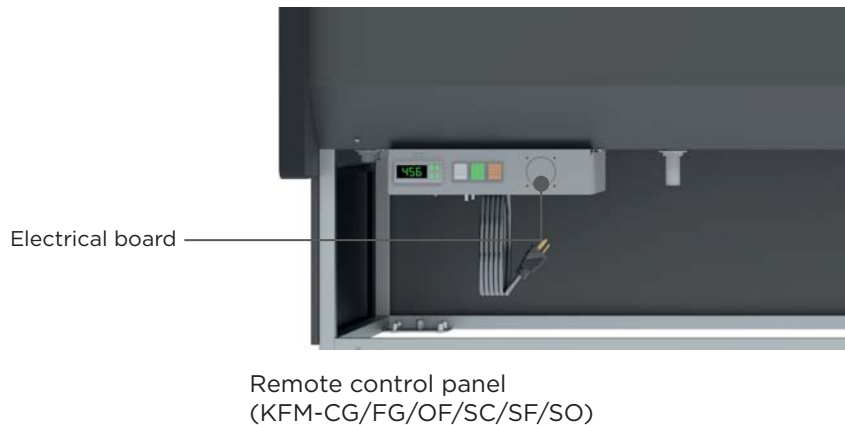
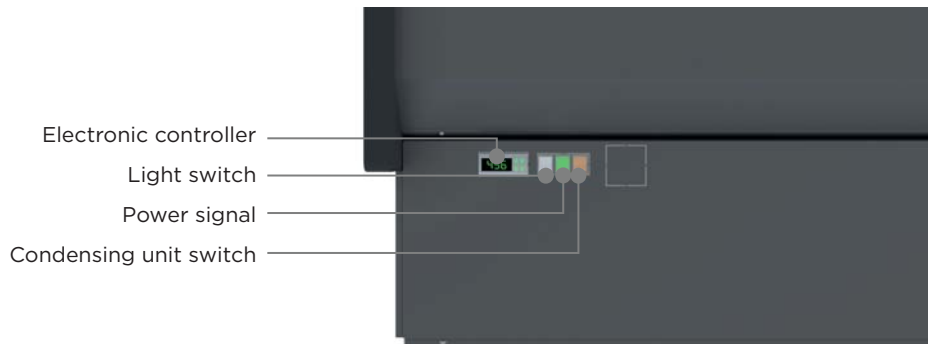
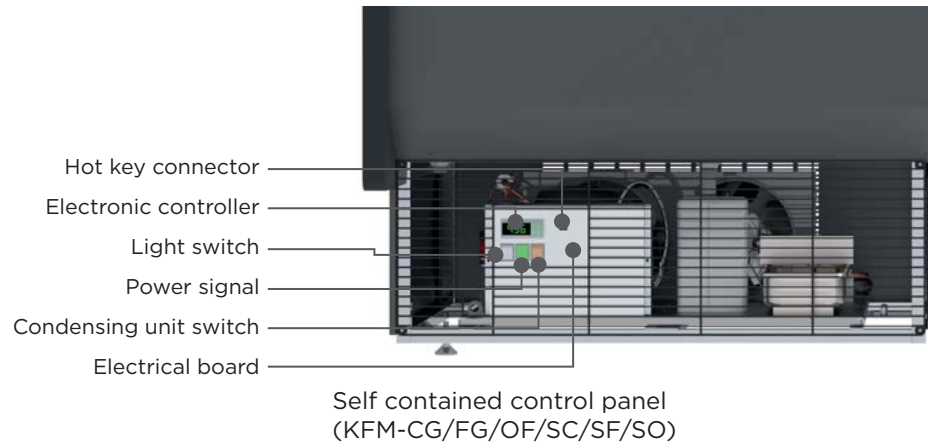

All self contained KFM series use the following equipment: capillary tube, finned coil ventilated systems (condenser/evaporator), hermetic compressor, electrical water evaporation system.

Model	Circuit pressure (psig)		Refrigerant and charge (OZ)	Defrost
	High side	Low side		
KFM-CG/SC/FG/SF/OF/SO-40-S	331	174	R 404A 14,10	Automatic 3/day
KFM-CG/SC/FG/SF/OF/SO-50-S	331	174	R 404A 19,40	Automatic 3/day
KFM-CG/SC/FG/SF/OF/SO-60-S	331	174	R 404A 19,40	Automatic 3/day
KFM-CG/SC/FG/SF/OF/SO-80-S	331	174	R 404A 25,39	Automatic 3/day
KFM-CG/SC/FG/SF/OF/SO-100-S	331	174	R 404A 37,74	Automatic 3/day
KFM-CG/SC/SF/FG/OF/SO-120-S	331	174	R 404A 42,33	Automatic 3/day

3.2 Refrigeration loads (remotes only)

Installation of remote equipment must be done by a qualified technician.

Model	BTU*/h	Expansion valve type	
KFM-CG/SC/FG/SF/OF/SO-40-R	2548	TS2	00
KFM-CG/SC/FG/SF/OF/SO-50-R	3015	TS2	00
KFM-CG/SC/FG/SF/OF/SO-60-R	3159	TS2	00
KFM-CG/SC/FG/SF/OF/SO-80-R	4345	TS2	00
KFM-CG/SC/FG/SF/OF/SO-100-R	5112	TS2	00
KFM-CG/SC/FG/SF/OF/SO-120-R	5472	TS2	00

*values presented are indicative for 14°F evap, and 90°F ambient.

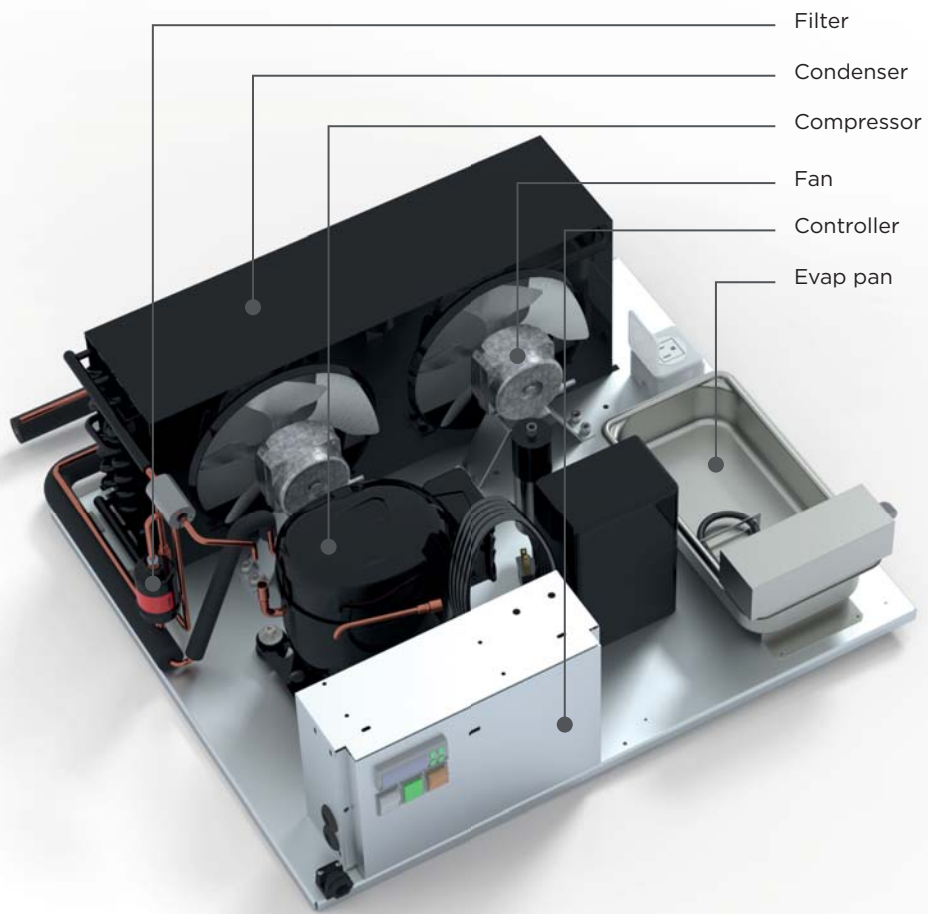

Light switch
 Power signal
 Power switch



Electrical board

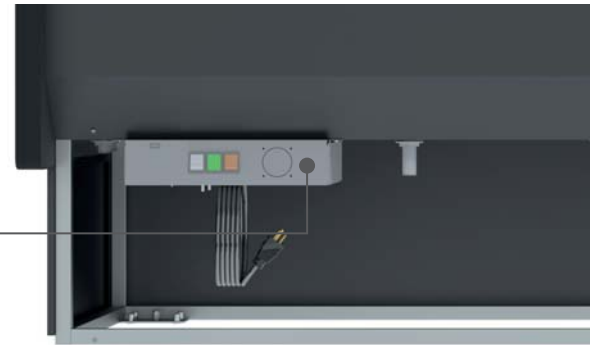

Dry control panel (KFM-CG/FG/OF)

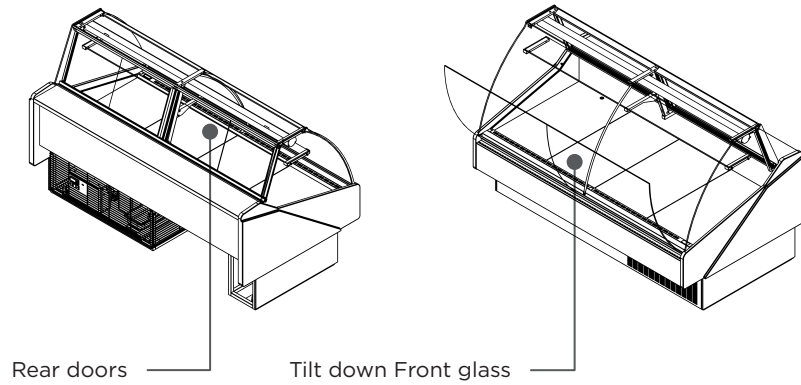
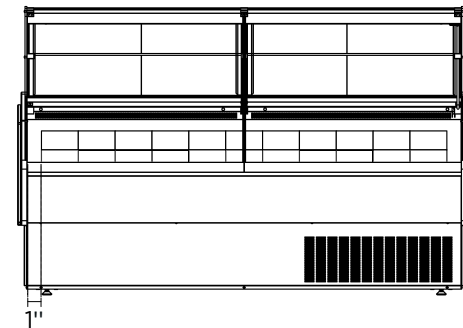
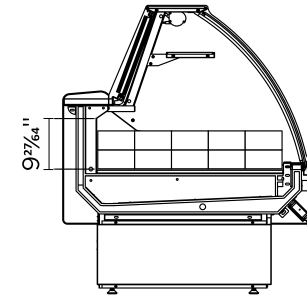
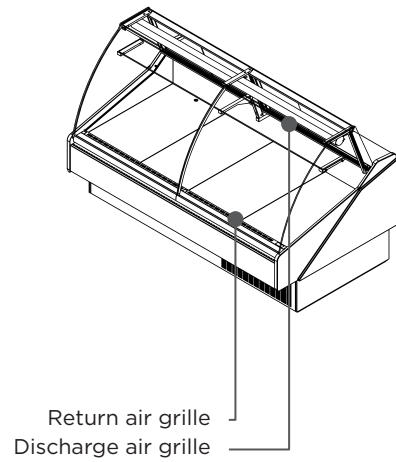

 Maintain doors closed after servicing.

9 - If any problem encountered, see troubleshooting or call a qualified technician!

3 Refrigeration

3.1 Self contained refrigeration equipment and defrost

The refrigeration equipment it's laid out in the base of the equipment.

2.5 Check serial, model numbers and requested options

Before start your equipment, check the serial number, model numbers and requested options.

This inspection should be made visually in the following items:

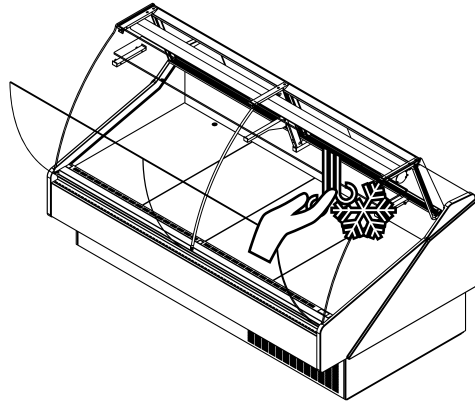

6 - Check air movement in the anti condensation system.

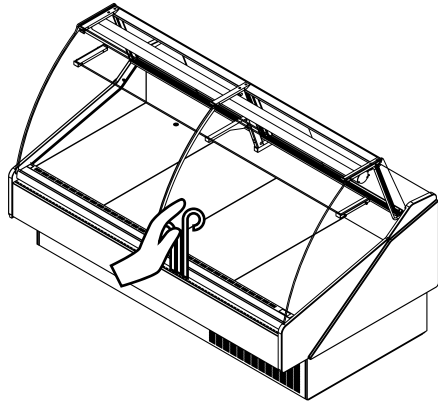

7 - Before loading, leave the equipment working for about 2h.

8 - Load your KFM-Series.



Loading must be done respecting loading limits and weight per square foot mentioned in page xx. This equipment is intended for maintaining temperature, be sure the products are cold, and not ambient temperature.



After loading check for any obstruction in the discharge and return air grilles.



Self contained numbers

MVP GROUP CORP. For service, please call: (514) 737-9701 www.mvpgroupcorp.com		COMMERCIAL REFRIGERATOR CONFORMS TO UL STANDARD 471 AND NSF STD 7 CERTIFIED TO CAN/CSA STD C22.2 NO. 120					
MADE IN PORTUGAL							
ETL MODEL <input type="text"/>		Intertek 4004083		Intertek		Intertek	
CASE FAMILY <input type="text"/>		SERIAL NO. <input type="text"/>		DATE MFG <input type="text"/>		120V CIRCUIT	
REF AMOUNT LEFT <input type="text"/>		REF AMOUNT RIGHT <input type="text"/>		REF TYPE <input type="text"/>		PSI HIGH SIDE <input type="text"/>	
PSI LOW SIDE <input type="text"/>		PSI <input type="text"/>		PSI <input type="text"/>		TOTAL CASE AMPS <input type="text"/>	
EVAP PAN <input type="checkbox"/>		DOOR HEATER <input type="checkbox"/>		LIGTHS <input type="checkbox"/>		ANTI-S FANS <input type="checkbox"/>	
EVAP FANS <input type="checkbox"/>		COND FANS <input type="checkbox"/>		COMP <input type="checkbox"/>		MINI BRANCH <input type="checkbox"/>	
REF AMOUNT LEFT <input type="text"/>		REF AMOUNT RIGHT <input type="text"/>		REF TYPE <input type="text"/>		CIRCUIT AMPACITY <input type="text"/>	
PSI HIGH SIDE <input type="text"/>		PSI LOW SIDE <input type="text"/>		PSI <input type="text"/>		MAX OVERCURRENT <input type="text"/>	
PSI <input type="text"/>		PSI <input type="text"/>		TOTAL CASE AMPS <input type="text"/>		PROTECTION AMPS <input type="text"/>	



Remote numbers

MVP GROUP CORP. For service, please call: (514) 737-9701 www.mvpgroupcorp.com		COMMERCIAL REFRIGERATOR CONFORMS TO UL STANDARD 471 AND NSF STD 7 CERTIFIED TO CAN/CSA STD C22.2 NO. 120					
MADE IN PORTUGAL							
ETL MODEL <input type="text"/>		Intertek 4004083		Intertek		Intertek	
CASE FAMILY <input type="text"/>		SERIAL NO. <input type="text"/>		DATE MFG <input type="text"/>		120V CIRCUIT	
REF AMOUNT LEFT <input type="text"/>		REF AMOUNT RIGHT <input type="text"/>		REF TYPE <input type="text"/>		PSI HIGH SIDE <input type="text"/>	
PSI LOW SIDE <input type="text"/>		PSI <input type="text"/>		PSI <input type="text"/>		TOTAL CASE AMPS <input type="text"/>	
EVAP PAN <input type="checkbox"/>		DOOR HEATER <input type="checkbox"/>		LIGTHS <input type="checkbox"/>		ANTI-S FANS <input type="checkbox"/>	
EVAP FANS <input type="checkbox"/>		COND FANS <input type="checkbox"/>		COMP <input type="checkbox"/>		MINI BRANCH <input type="checkbox"/>	
REF AMOUNT LEFT <input type="text"/>		REF AMOUNT RIGHT <input type="text"/>		REF TYPE <input type="text"/>		CIRCUIT AMPACITY <input type="text"/>	
PSI HIGH SIDE <input type="text"/>		PSI LOW SIDE <input type="text"/>		PSI <input type="text"/>		MAX OVERCURRENT <input type="text"/>	
PSI <input type="text"/>		PSI <input type="text"/>		TOTAL CASE AMPS <input type="text"/>		PROTECTION AMPS <input type="text"/>	

2.6 Warning/Caution labels

 Before starting, HYDRA KOOL products have caution and warning labels to be respected.

Self contained labels

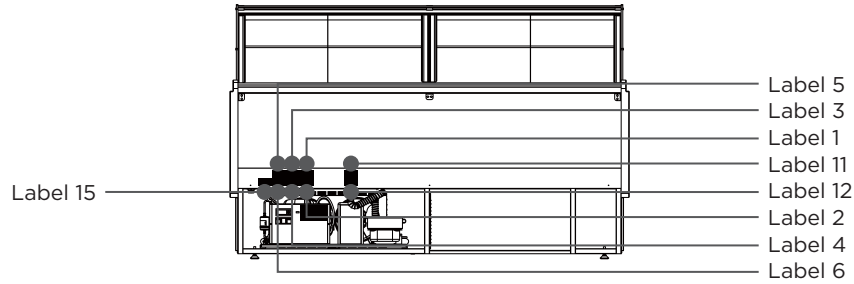

Remote labels

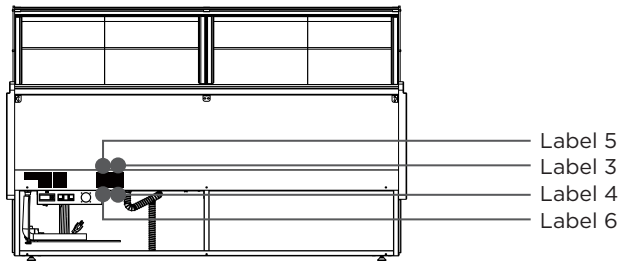

Dry labels

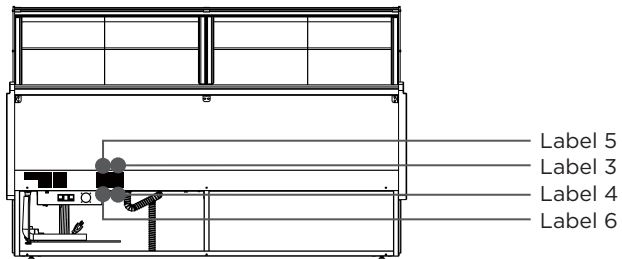

2.10 Plugging and start

To start your equipment follow the steps:

1 - Check for page with parameters inside the manual.

2 - After uncrating and placed the equipment respecting all warnings set in 2.1 chapter, and all switches are set to off position, connect the equipment.

 Make sure you have the correct outlet!

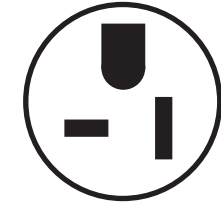
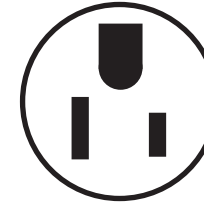

3 - Check lights, using button referenced on chapter 2.4. If not working consult the maintenance chapter.

4 - Turn ON power button referenced in 2.4 chapter.

 Noise will be heard when compressor starts! If compressor doesn't start, call a technician!

5 - Open the door and check for air movement in the discharge air grille.

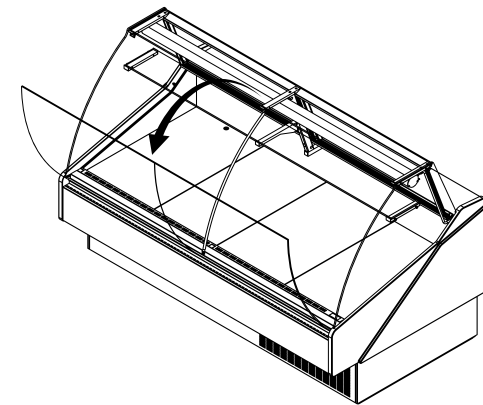

10

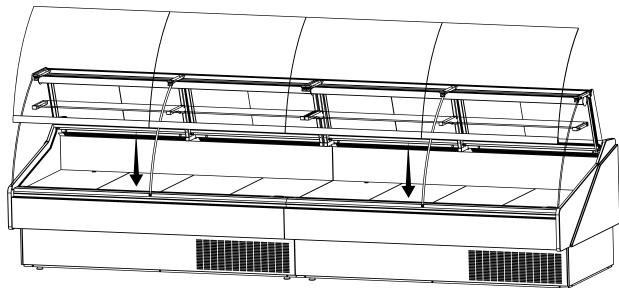
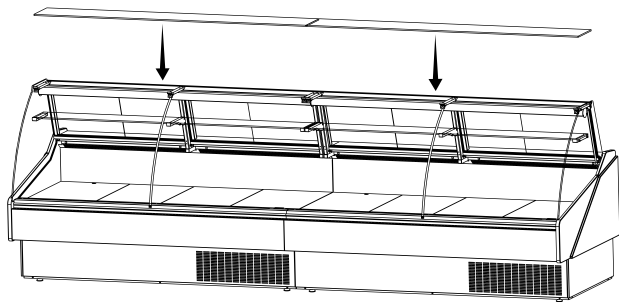
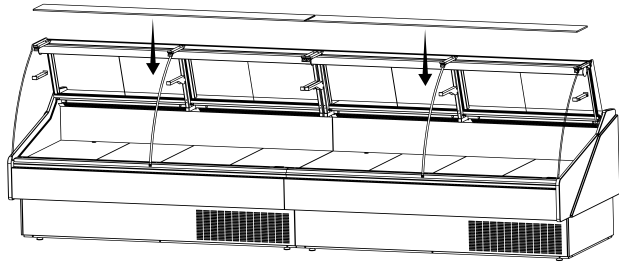
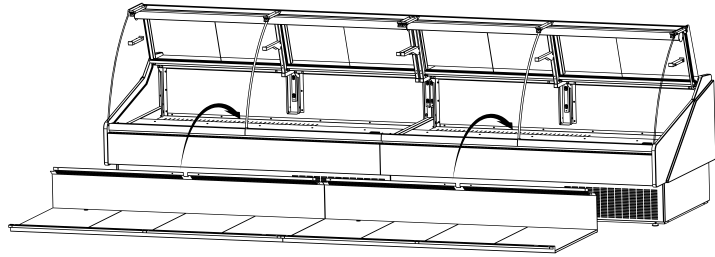

Self contained labels

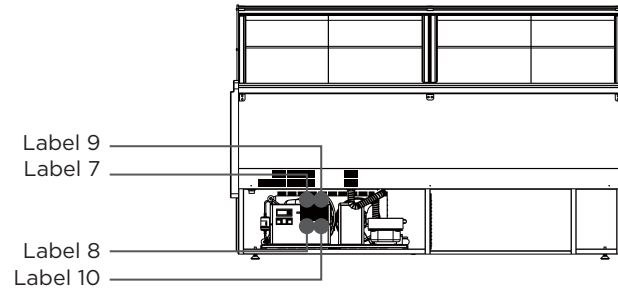

Remote labels

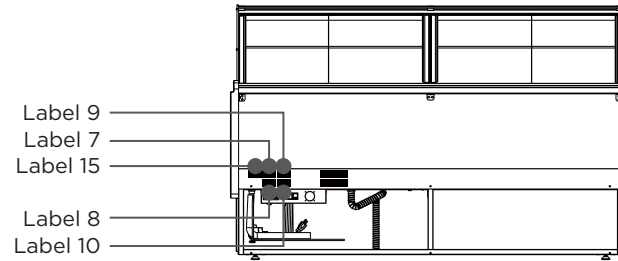

Dry labels

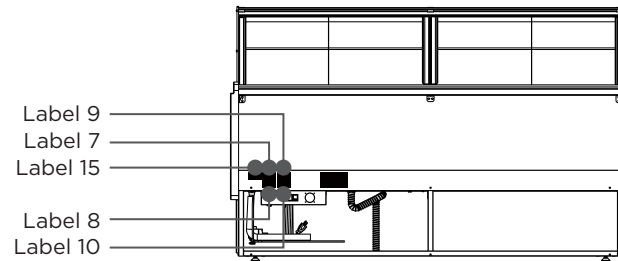

Self contained, Remote, Dry and Seafood labels (evaporator)

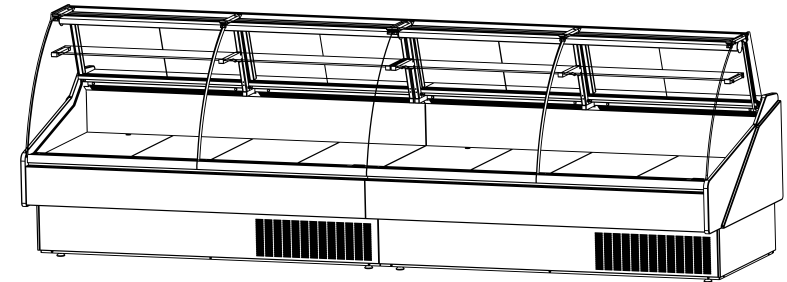
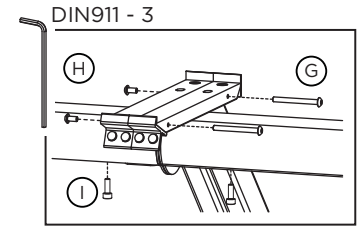
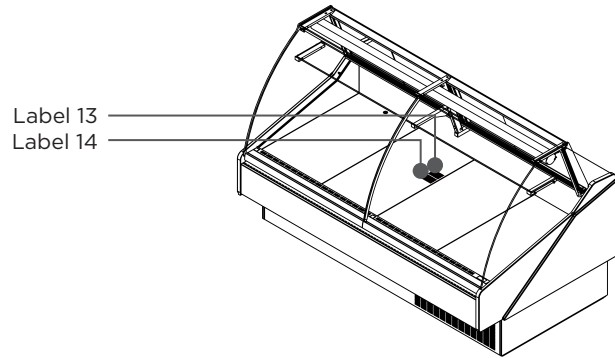

Label 1

CAUTION
MOVING PARTS.
DO NOT OPERATE UNIT
WITH (PART) REMOVED

Label 2

ATTENTION
PIÈCES MOBILES.
NE FAIRE PAS
FONCTIONNER AVEC
DES PIÈCES ENLEVER

Label 3

-NOTE-
THIS A TYPE 1 CASE AND IS
DESIGNED TO OPERATE AT
THE FOLLOWING STORE
CONDITIONS THAT DOES NOT
EXCEED
75 F AND 55% R.H.

Label 4



-NOTE-
CETTE VITRINE TYPE 1 EST
CONÇUE POUR FONCTIONNER
SELON LES CONDITIONS DU
MAGASIN ET NE DOIT
DÉPASSER
75 F AND 55% R.H.

Label 5

-NOTE-
THIS EQUIPMENT IS INTENDED
FOR THE STORAGE
AND DISPLAY OF PACKAGED
FOOD PRODUCTS ONLY

Label 6

-NOTE-
CET EQUIPEMENT EST PREVU
UNIQUEMENT POUR LE
STOCKAGE ET EXPOSITION DE
PRODUITS ALIMENTAIRES
EMBALLER

-  1x - DIN7380 M5x50
-  1x - DIN7380 M5x10
-  1x - DIN912 M4x12

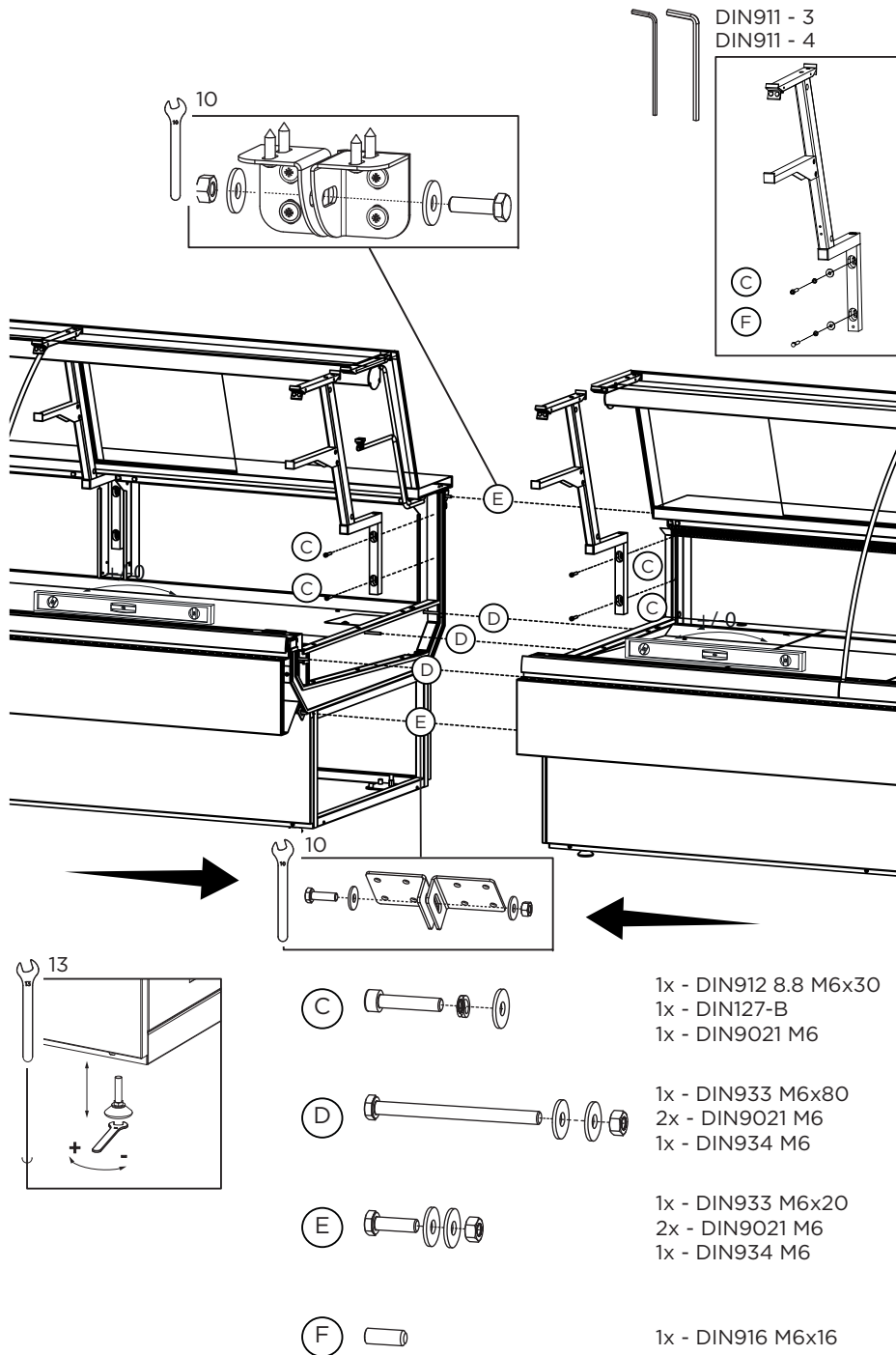

Label 7

CAUTION

DISCONNECT ALL POWER.
MAY HAVE MORE THEN
ONE DISCONNECT SWITCH

Label 8

ATTENTION

DEBRANCHER TOUTE
COURANT.
IL PEUT AVOIR PLUS D'UN
INTERRUPTEUR

Label 9

CAUTION

RISK OF ELECTRIC SHOK.
DISCONNECT ALL
POWER BEFORE
SERVICING UNIT

Label 10

ATTENTION

RISQUE DE CHOC
ELECTRIQUE.
AVANT TOUT TRAVAIL
COUPER LE COURANT

Label 11

CAUTION

HOT PARTS.
DO NOT OPERATE UNIT
WITH (PART) REMOVED

Label 12

ATTENTION

PIÈCES BRULANTES.
NE FAIRE PAS
FONCTIONNER AVEC LES
PIÈCES ENLEVER

Label 13

CAUTION

HAZARDOUS MOVING PARTS.
DO NOT OPERATE UNIT
WITH DECK PANS

Label 14

ATTENTION

PIÈCES MOBILES
DANGEREUSES. NE FAIRE
PAS FONCTIONNER AVEC
DES PIÈCES ENLEVER

Label 15

Warning

- This appliance requires a properly grounded dedicated circuit using a NEMA rated wall receptacle do not remove the grounding prong on the plug or the risk of an injury due to shock from the ungrounded electrical service may occur.
- This product can expose an individual to chemicals that have been identified by the state of California to possibly be dangerous leading to various diseases birth defects or other human reproductive system harm. For more information go to www.p65warnings.ca.gov.

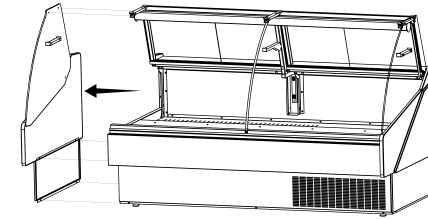
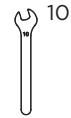

2.7 Check your electrical installation

This equipment is intended to be connected to an outlet with 115V/ 60Hz/ 1 phase.



Nema-5-15P

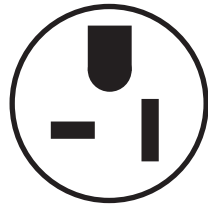

Nema-5-20P

2.8 Electrical, drain and refrigeration connections (remotes only)

Installation and service must be performed by a qualified technician.

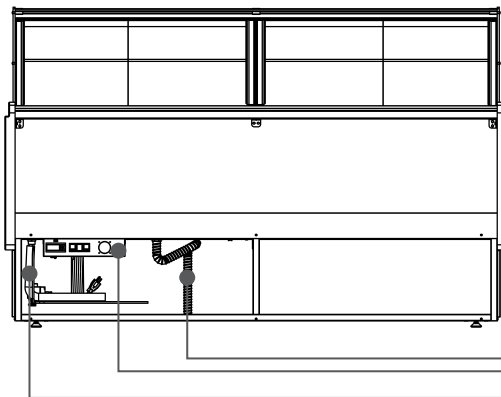

Prepare a drain installation

All electrical connections must be done from the electrical board Equipments for remote installation come with nitrogen under pressure and an easy prep kit (tubing connections needed only) for installation.

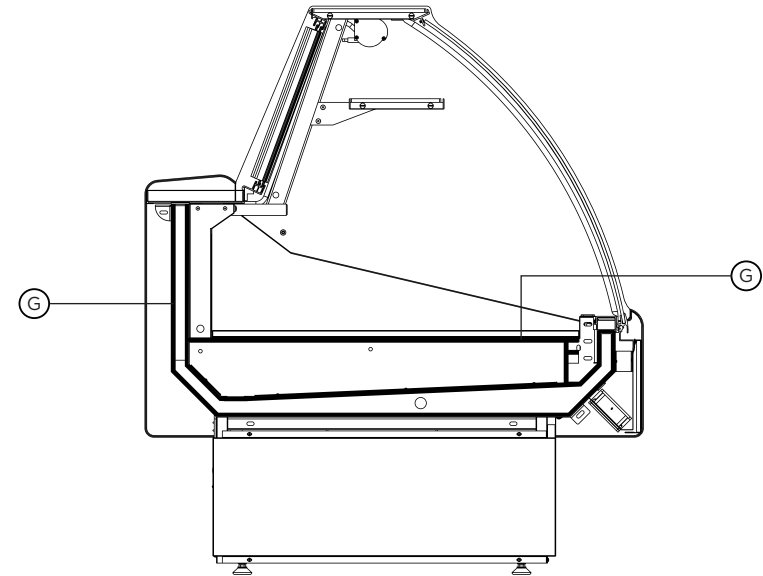

2X - FIT00000427 (91⁴⁹/₆₄"

2.9 Joining

For joining follow the steps described.

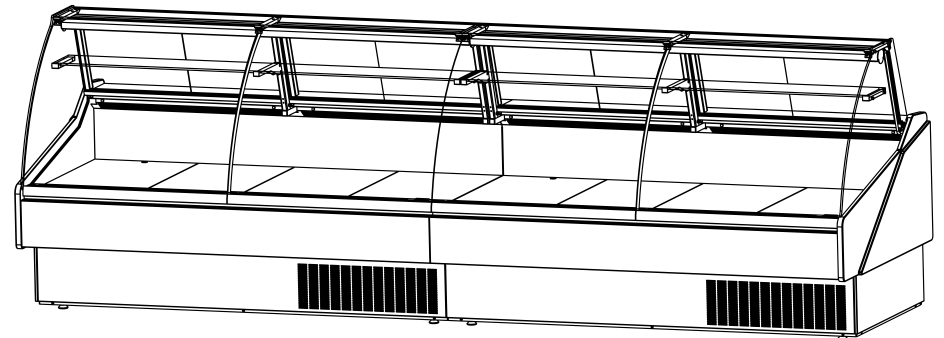
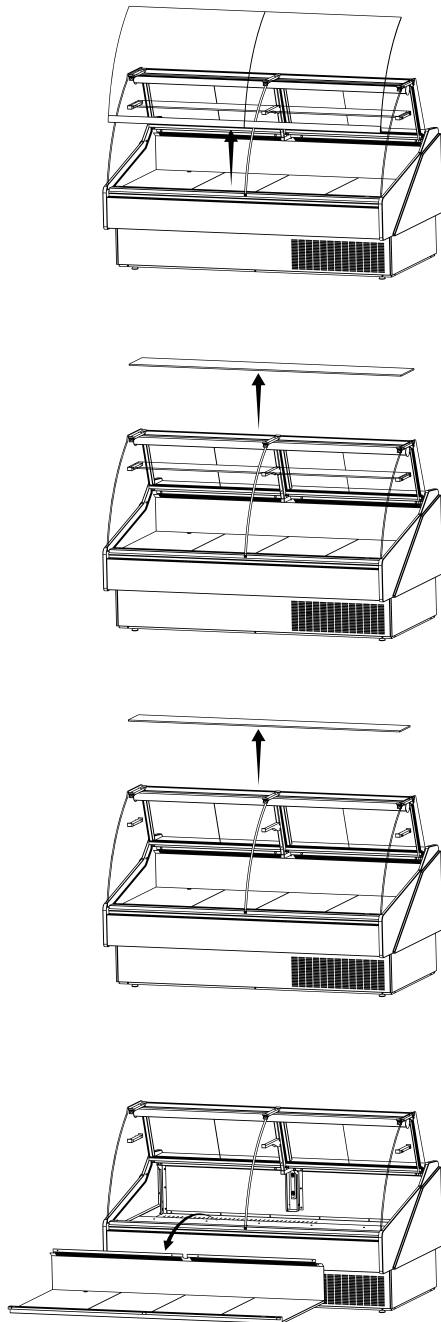

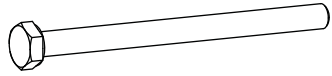

3x - PAR00601013 DIN933 M6x80



4x - PAR00801102 DIN912 8.8

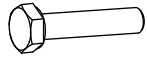

2x - PAR00601007 DIN933 M6x20



4x - ANL00101006 DIN 127-B



14x- ANL00501006 DIN9021 M6

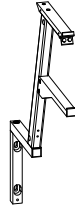

2x - BRA09M02000 VA 71



5x - PRC00101006 DIN934 M6

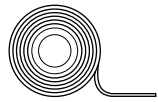

2X FIT00000202 A100 04 (153⁹/₁₆"

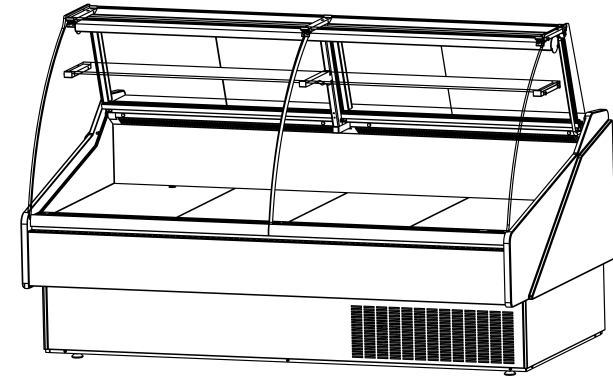

2x KFM-CG

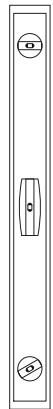

1x

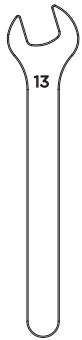

1x

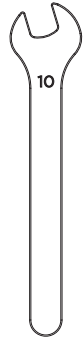

1x

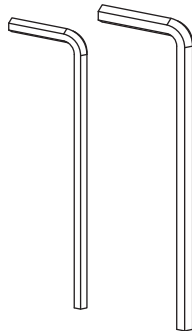

DIN911 - 3/4

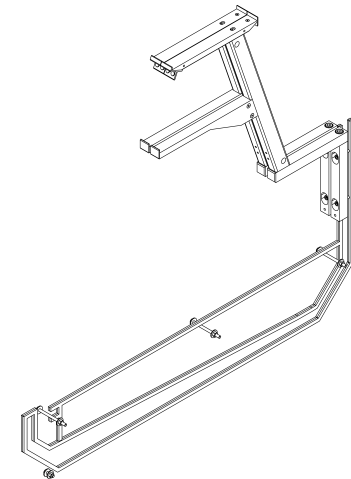

KIT0005U02000