

## GLASS DISPLAY DIPPING FREEZER

### MODEL DIPC-71

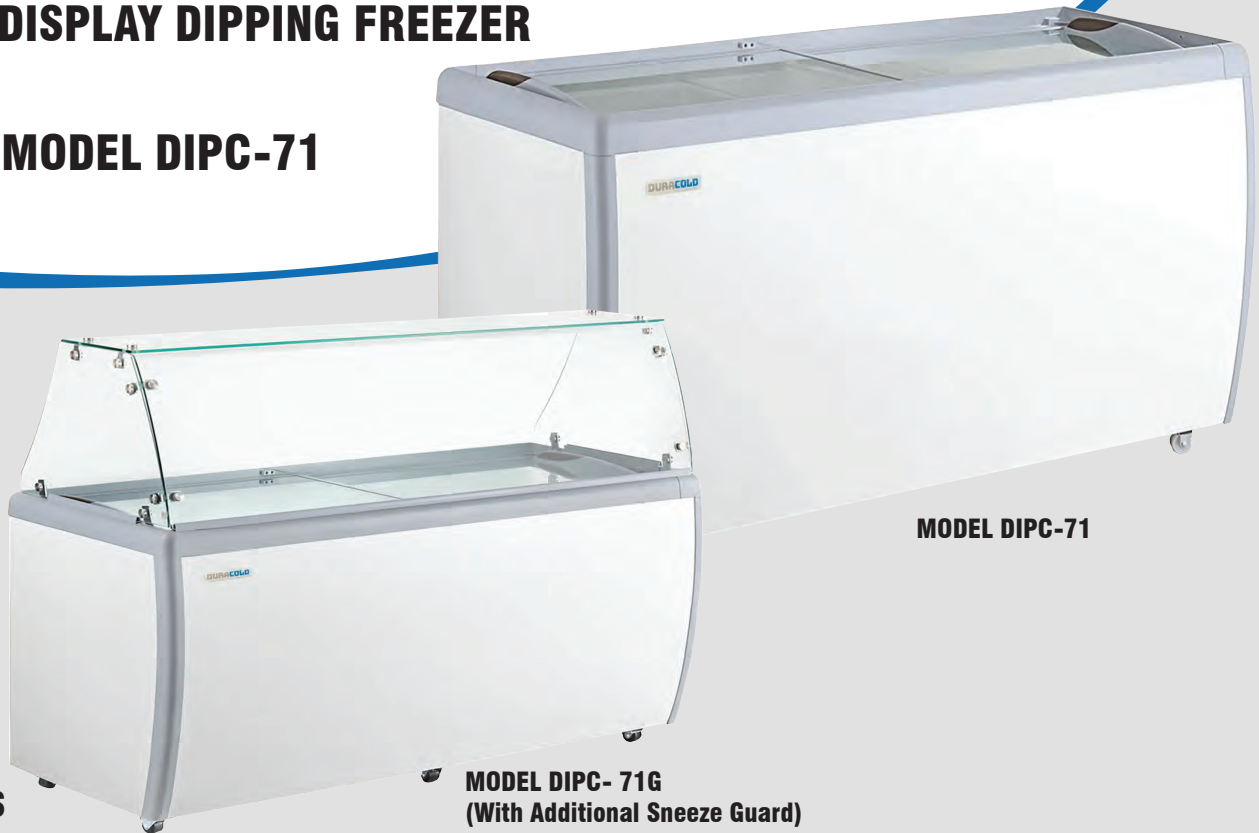

GLASS DISPLAY DIPPING FREEZER

MODEL DIPC-71

### FEATURES

- White Cabinet With Grey Framing
- White Painted Aluminum Interior
- Gravity Cooling System
- Two Sliding Glass Doors with Lock
- Includes Tub Display Holders
- Total Capacity of 22 Tubs (12 for Display , 10 for Storage)
- Available With or Without Sneeze Guard
- Mechanical Dial Temperature Control
- Lockable 2" Casters
- 1/2 + HP Compressor

MODEL DIPC- 71G  
(With Additional Sneeze Guard)

### TEMPERATURE

- Interior Temperature Range: 2°C to -26°C (35.6°F to -14.8°F)

### WARRANTY

- 1 Year Parts And Labour
- 5 Year Compressor Warranty

Toll Free: 1-833-669-8003

2884 SLOUGH STREET, UNIT 1, MISSISSAUGA, ONTARIO CANADA L4T 1G3

© DURACOLD REFRIGERATION

|                    |                |
|--------------------|----------------|
| <b>MODEL</b>       | <b>DIPC-71</b> |
| <b>VOLTS</b>       | <b>115 V</b>   |
| <b>WATTS</b>       | <b>460 W</b>   |
| <b>AMPS</b>        | <b>4 A</b>     |
| <b>REFRIGERANT</b> | <b>R290</b>    |

|                           |                |
|---------------------------|----------------|
| <b>OVERALL DIMENSIONS</b> |                |
| <b>WIDTH</b>              | <b>71"</b>     |
| <b>DEPTH</b>              | <b>28"</b>     |
| <b>HEIGHT</b>             | <b>34 1/2"</b> |
| <b>NET WEIGHT</b>         | <b>240 Lbs</b> |

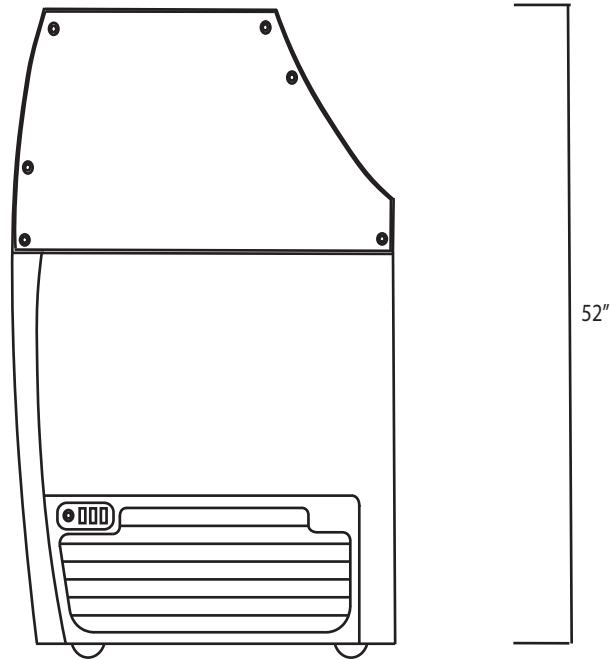
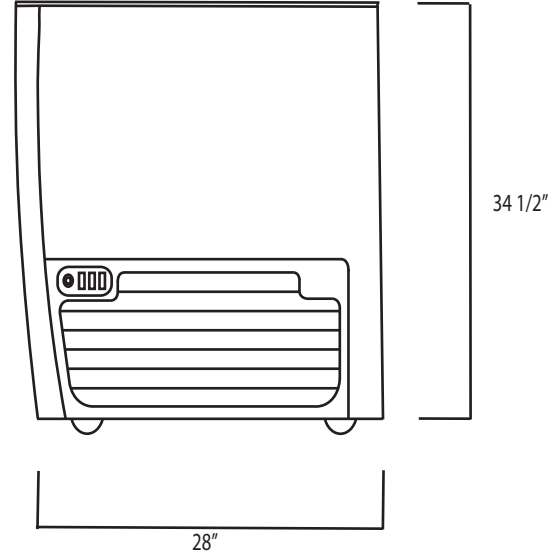
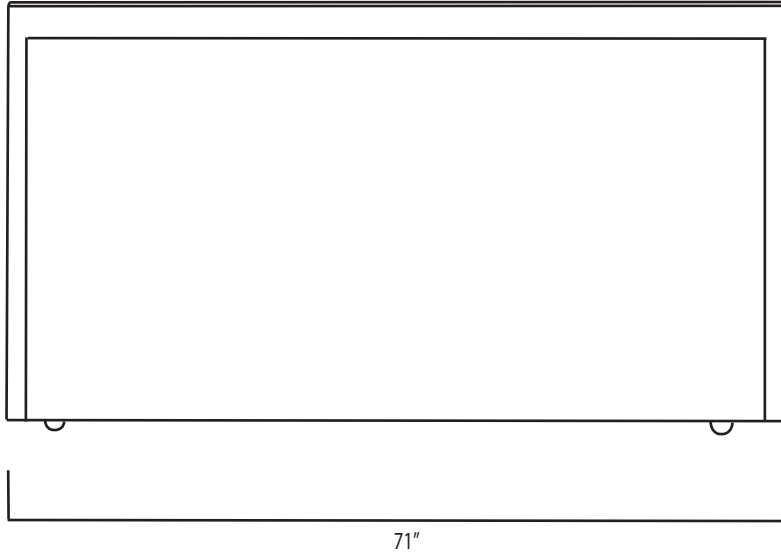

**CERTIFICATIONS:**



Specifications are subject to change without notice

Toll Free: 1-833-669-8003

2884 SLOUGH STREET, UNIT 1, MISSISSAUGA, ONTARIO CANADA L4T 1G3

© DURACOLD REFRIGERATION