

GLASS DISPLAY DIPPING FREEZER

MODEL DIPC-60

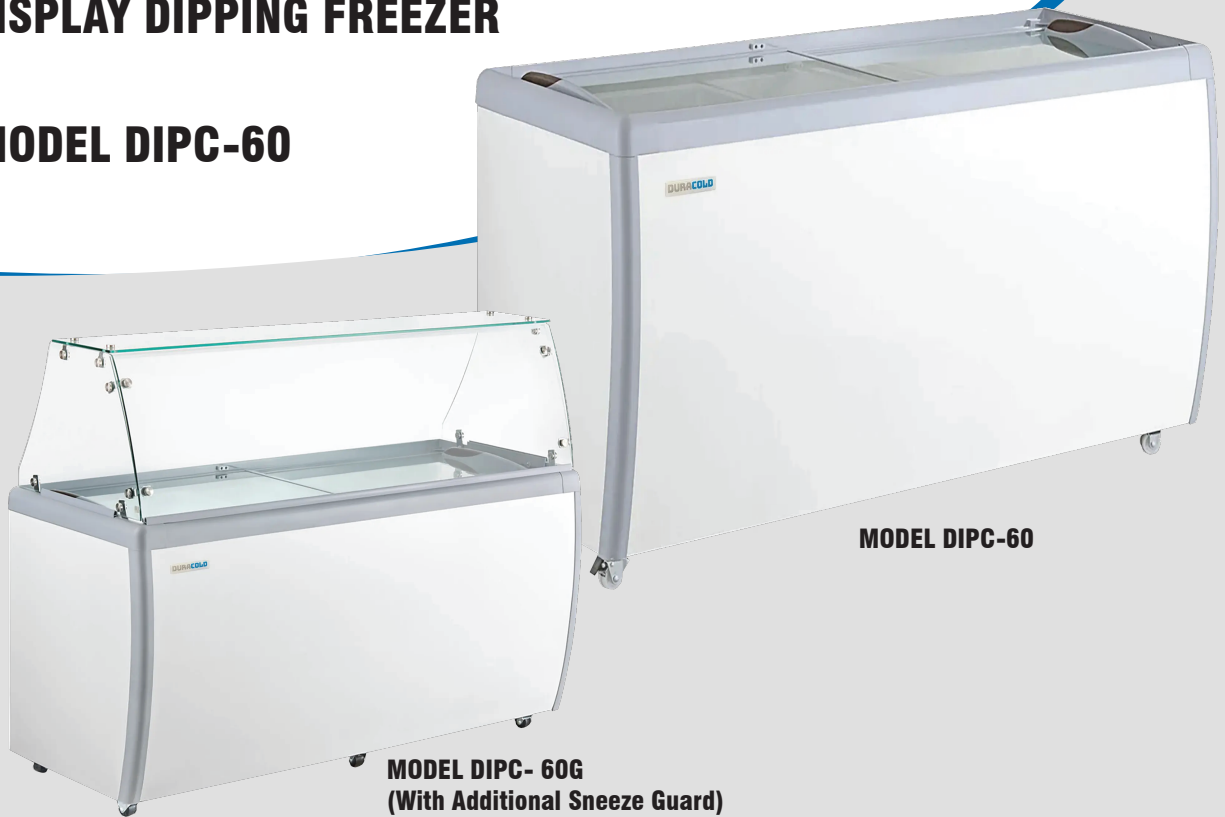

FEATURES

- White Cabinet With Grey Framing
- White Painted Aluminum Interior
- Gravity Cooling System
- Two Sliding Glass Doors with Lock
- Includes Tub Display Holders
- Total Capacity of 18 Tubs (10 for Display , 8 for Storage)
- Available With or Without Sneeze Guard
- Mechanical Dial Temperature Control
- Lockable 2" Casters
- 1/2 + HP Compressor

MODEL DIPC- 60G
(With Additional Sneeze Guard)

TEMPERATURE

- Interior Temperature Range: 2°C to -26°C (35.6°F to -14.8°F)

WARRANTY

- 1 Year Parts And Labour
5 Year Compressor Warranty

GLASS DISPLAY DIPPING FREEZER

MODEL DIPC-60

Toll Free: 1-833-669-8003

2884 SLOUGH STREET, UNIT 1, MISSISSAUGA, ONTARIO CANADA L4T 1G3

© DURACOLD REFRIGERATION

MODEL	DIPC-60
VOLTS	115 V
WATTS	460 W
AMPS	4 A
REFRIGERANT	R290

OVERALL DIMENSIONS	
WIDTH	60"
DEPTH	28"
HEIGHT	34 1/2"
NET WEIGHT	176 Lbs

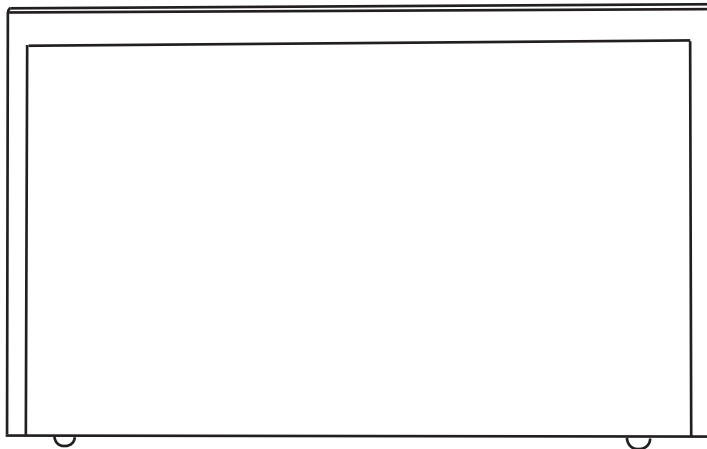

60"

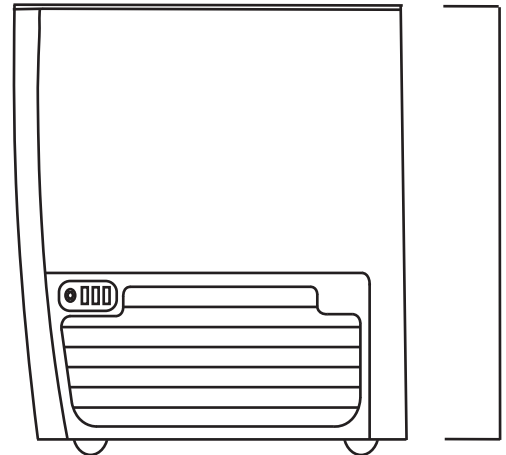

34 1/2"

28"

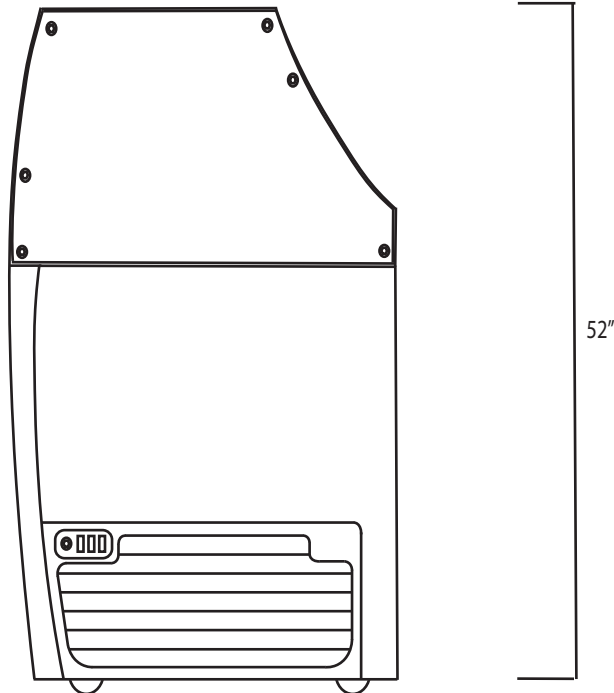

52"

CERTIFICATIONS:



NEMA 5-15P

Specifications are subject to change without notice

Toll Free: 1-833-669-8003

2884 SLOUGH STREET, UNIT 1, MISSISSAUGA, ONTARIO CANADA L4T 1G3

© DURACOLD REFRIGERATION