

GLASS DISPLAY DIPPING FREEZER

MODEL DIPC-39



MODEL DIPC- 39G
(With Additional Sneeze Guard)



MODEL DIPC-39

GLASS DISPLAY DIPPING FREEZER

MODEL DIPC-39

FEATURES

- White Cabinet With Grey Framing
- White Painted Aluminum Interior
- Gravity Cooling System
- Two Sliding Glass Doors with Lock
- Includes Tub Display Holders
- Total Capacity of 10 Tubs (6 for Display , 4 for Storage)
- Available With or Without Sneeze Guard
- Mechanical Dial Temperature Control
- Lockable 2" Casters
- 1/3 + HP Compressor

TEMPERATURE

- Interior Temperature Range: 2°C to -26°C (35.6°F to -14.8°F)

WARRANTY

- 1 Year Parts And Labour
- 5 Year Compressor Warranty

Toll Free: 1-833-669-8003

2884 SLOUGH STREET, UNIT 1, MISSISSAUGA, ONTARIO CANADA L4T 1G3

© DURACOLD REFRIGERATION

MODEL	DIPC-39
VOLTS	115 V
WATTS	402.5 W
AMPS	3.5 A
REFRIGERANT	R290

OVERALL DIMENSIONS	
WIDTH	39"
DEPTH	28"
HEIGHT	34 1/2"
NET WEIGHT	126 Lbs

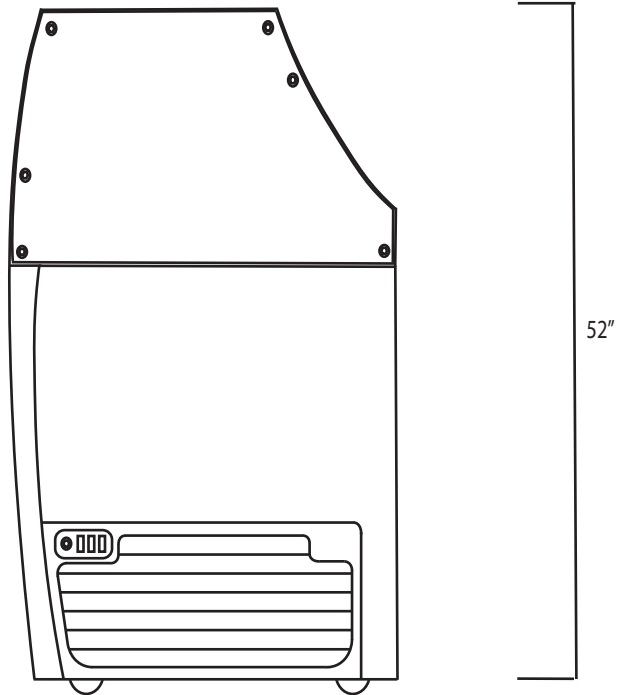
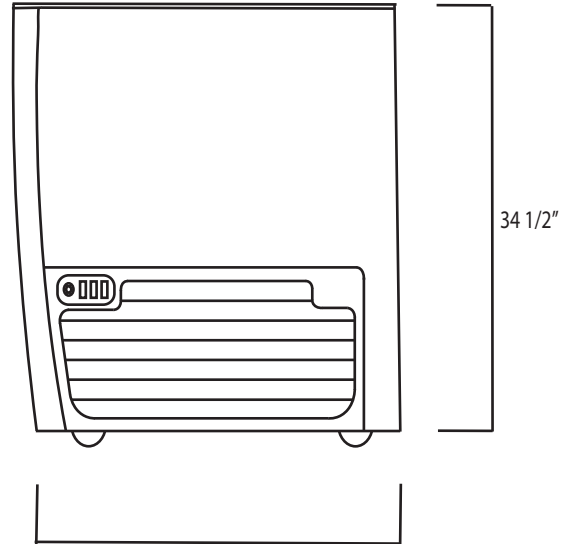
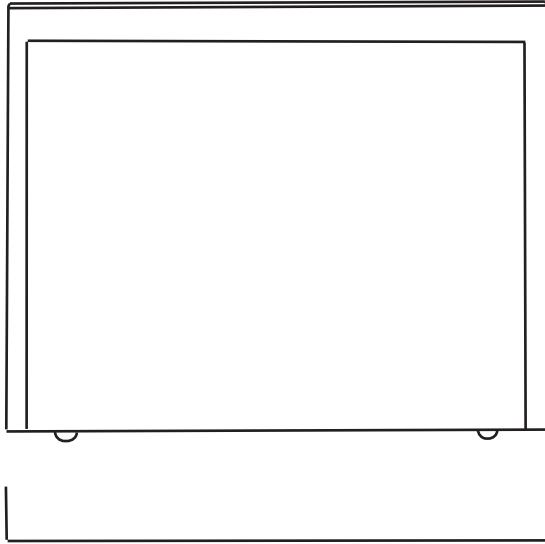

CERTIFICATIONS:



Specifications are subject to change without notice

Toll Free: 1-833-669-8003

2884 SLOUGH STREET, UNIT 1, MISSISSAUGA, ONTARIO CANADA L4T 1G3

© DURACOLD REFRIGERATION