

## GAS CABINET BASE HYDRAULIC TILTING SKILLET

 GMTS-60

### OPERATION SHALL BE BY:

 Natural Gas

 Propane Gas

Gas fired skillet operating on 115 VAC, 1 Phase, 60Hz

### STANDARD FEATURES:

- 1/2 H.P. hydraulic tilting system for smooth and precise tilting action
- Stainless steel cover with spring assist hinges, full width handle, no-drip condensate guide and vent port with swing cover
- 10 gauge type 304 stainless pan with 3/4" triple-ply aluminum core cooking surface
- All stainless steel exterior
- Pour lip strainer
- Solid state temperature control
- Solid state electronic ignition

### OPTIONS & ACCESSORIES AT ADDITIONAL COST

- |  |   |  |
|--|---|--|
| <input type="checkbox"/> 220 VAC, 1 phase, 50 Hz (GSVS-1)        | <input type="checkbox"/> Pan carrier (PC-3)                                   | <input type="checkbox"/> Single pantry faucet & bracket with 68" pot filler (SP-RSH) |
| <input type="checkbox"/> Etched liter markings (LMS-226)         | <input type="checkbox"/> Steam pan insert (SPI-60)                            | <input type="checkbox"/> Double pantry faucet & bracket with 68" pot filler (DP-RSH) |
| <input type="checkbox"/> 2" draw off valve with strainer (TVT-2) | <input type="checkbox"/> 12" Single pantry faucet with swing spout (SF-12)    |  |
| <input type="checkbox"/> 3" draw off valve with strainer (TVT-3) | <input type="checkbox"/> 12" Double pantry faucet with swing spout (DF-12)    |  |
| <input type="checkbox"/> Correctional Package                    | <input type="checkbox"/> 3" Stainless steel faucet plumbing enclosure (SPE-1) |  |

### STANDARD CONSTRUCTION SPECIFICATIONS

Shall be a Crown model **GMTS-60** gas fired hydraulic tilting skillet, AGA/CGA and NSF certified.

The unit shall have a spring assisted hinged stainless steel cover, complete with handle and a no drip condensate guide.

The pan body shall have a sloped front, be front hinged for tilting and easy pour control, comes complete with removable pour lip strainer, and with etched gallon markings.

The pan is formed from 10 gauge 304 stainless steel with a #4 finish exterior and polished interior with covered corners for easy cleaning.

Cooking surface shall be 3/4" triple-ply construction with 3/8" thick aluminum core ensuring even heat distribution over entire cooking surface.

The pan shall be mounted on a heavy duty welded angle constructed frame fitted with 6" (152 mm) stainless steel legs with 4 adjustable flanged for securing to the floor.

Enclosed with #4 finish type 304 stainless steel with removable side panels and two stainless steel front cabinet doors.

All controls are mounted in the cabinet base which include a solid state thermostat, temperature light, tilt switch, electronic ignition, tilt safety switch and hydraulic lift system powered by a 1/2 HP electric motor for smooth and precise tilting action.

The high limit thermostat is located on the pan bottom.

Cooking temperatures are between 100°F and 450°F (38°C and 232°C). Gas supply to the burners automatically shuts off when the pan is tilted.



Approval Notes: \_\_\_\_\_

\_\_\_\_\_

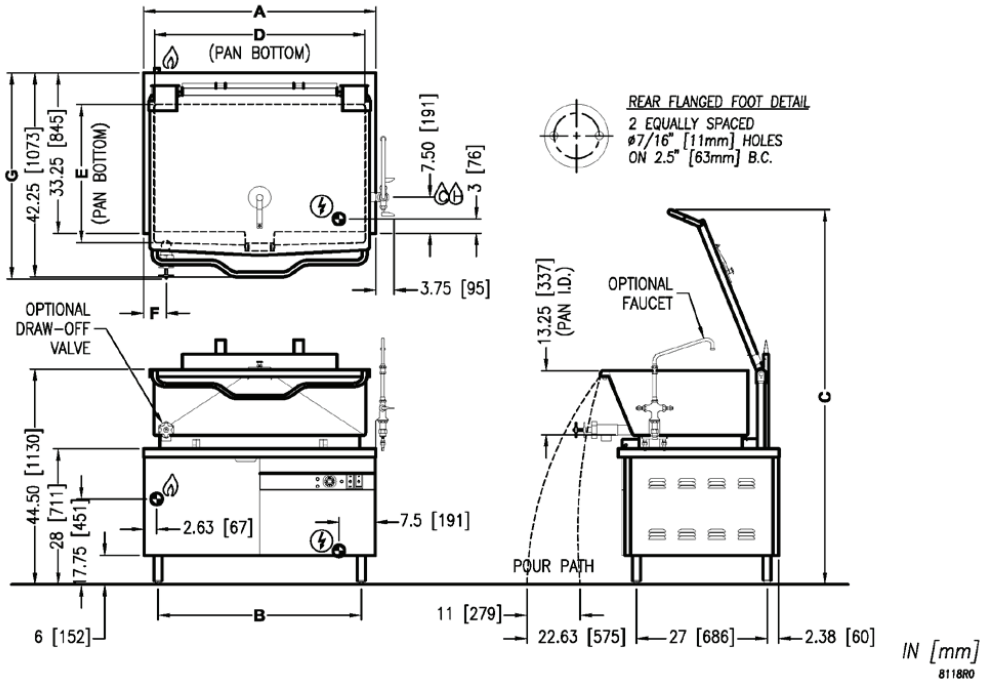

### SERVICE CONNECTIONS

- ELECTRICAL CONNECTIONS: Unless otherwise specified, Field Wire Electrical Connection to be 120 Volts, 60 Hz, single phase with grounding wire. 10 Amp minimum supply.
- GAS CONNECTION: 3/4" IPS. A gas shut-off valve is installed in supply piping.
- COLD WATER: 3/8" O.D. tubing to faucet (OPTIONAL)
- HOT WATER: 3/8" O.D. tubing to optional faucet (OPTIONAL)

### DIMENSIONS

MODEL	CAPACITY	A	B	C	D	E	F	G	
GMTS-60	60 Gallons (227 liters)	48" (1219 mm)	42" (1067 mm)	77.50" (1969 mm)	42.88" (1089 mm)	23" (584 mm)	4.75" (121 mm)	Ø2	Ø3
								42.63" (1083 mm)	46.5" (1181 mm)

### GAS CHARACTERISTICS

MODEL	GAS SUPPLY		
	BTU/HR	kw/HR	Supply Pipe Pressure (W.C)
GMTS-60	100,000	29.3	Natural 6" - 14" (152 mm - 356 mm)
			Propane 11" - 14" (279 mm - 356 mm)

\* For use on non-combustible floors only.

### SPECIFICATIONS

MODEL	CAPACITY			MODEL	SHIPPING WEIGHT	MINIMUM CLEARANCE *	
	BTU	GALLON	LITER			Side	Back
GMTS-60	100,000	60	226	GMTS-60	925 lbs. [420 kg]	3" [76 mm]	6" [152 mm]

**INTENDED FOR COMMERCIAL USE ONLY.  
NOT FOR HOUSEHOLD USE.**

