

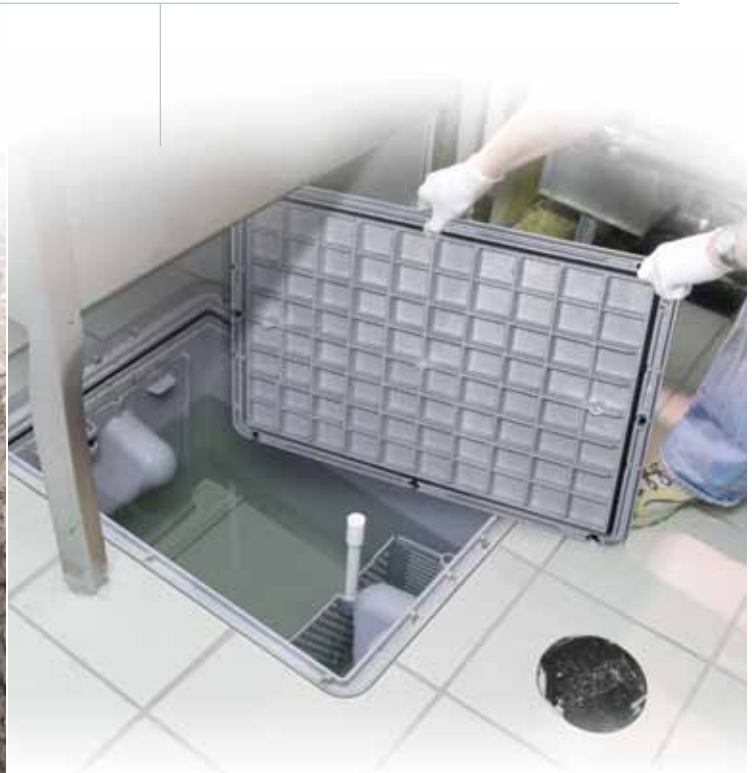

# GREASE INTERCEPTORS

CANPLAS SECTION 22 13 23 GREASE INTERCEPTORS



Engineering grease management solutions for plumbing and food service professionals

**canplas**<sup>®</sup>

an *O*Altaxis company

[www.endurainterceptor.com](http://www.endurainterceptor.com)



## Molding a Better Future

Canplas is one of North America's leading producers of plastic products for the building and construction Industries and part of the Aliaxis Group of Companies. Specializing in injection moulded products, Canplas has five decades of expertise and experience in the manufacturing and distribution of plastic plumbing products, processing multiple materials and producing millions of fittings and products on an annual basis.

Endura grease interceptors have demonstrated effective, efficient and consistent performance with over a decade of field installation and operation. Endura is a multi-patented product built to withstand the toughest environments and provides the flexibility of in-floor, on-floor and semi-recessed application. Canplas has been instrumental in changing the traditional practices regarding the installation of grease management solutions, plastic alternatives to metal interceptors being now substantially accepted Nationwide as the new standard for grease management in commercial foodservice applications.

## Canplas Earth friendly solutions for Grease Management

Canplas is committed to the continuous improvement of our environmental performance and to meeting or exceeding the requirements of all applicable environmental laws and regulations.

### Durability

- Fewer installations and replacements result in lower lifetime costs & less landfill waste.
- Injection molded in engineered thermoplastics, Endura Grease Interceptors will not corrode, chip, or peel, even under the most severe applications
- Durability provides consistent operation – no compromise of effectiveness due to deterioration of key parts

### Green by Design



- Light-weight but durable grease interceptor units enable smaller carbon footprint and low-emissions transport
- Injection and rotationally molded thermoplastic requires less energy to produce than metal grease interceptors
- Endura interceptors are manufactured using up to 100% recompounded material

## Internal Application Grease Interceptors



### Endura Compact 7GPM - 10GPM - 15GPM Models

3907A02 - 7GPM (0.44 LPS) 2" (51 mm) connection  
3910A02 - 10GPM (0.63 LPS) 2" (51 mm) connection  
3915A02C - 15GPM (0.94 LPS) 2" (51 mm) connection

Compact models use a development of the patented Canplas baffle system to enhance separation performance at low flow rates. EZ-Clean tank design – Aids exterior cleaning.



### Endura Lo-PRO Grease Interceptor 25GPM Model

3925A02LO 25GPM (1.6 LPS) 2" (51 mm) connection

Endura® Lo-PRO for tight on-floor applications where space is at a premium. Same dimensional footprint as 35gpm and 50gpm Endura® models. Overall height 11 inches, still meeting requirements of ASME112.14.3. Internal components can be removed in less than 6" of additional clearance.



### Endura 20GPM

3920A02 20GPM (1.26 LPS) 2" (51 mm) connection

Our original tank, 20gpm units are perhaps the most commonly installed product. It suits on-floor and in-floor application respectively.



### Endura 25GPM - 35GPM Models

3925ALT02 25GPM (1.6 LPS) 2" (51 mm) connection  
3925ALT03 25GPM (1.6 LPS) 3" (76 mm) connection  
3935A03 35GPM (2.2 LPS) 3" (76 mm) connection  
3935A04 35GPM (2.2 LPS) 4" (110 mm) connection

35gpm uses structured foam molding technology provides rigidity and durability while reducing unit weight. Diffuser baffle aids separation at increased flow rates.



### Endura 50GPM Models

3950A03 50GPM (3.2 LPS) 3" (76 mm) connection  
3950A04 50GPM (3.2 LPS) 4" (110 mm) connection

A tall version of our 35gpm model the 50gpm interceptor uses common parts incorporating all the best features of the Endura product design in a comparatively light weight solution to that of its metal competitors.



### EnduraXL 75GPM Models

4075A04 75 GPM (4.74 L/Sec) 4" (110 mm) Connections  
4075A04T 75 GPM (4.74 L/Sec) 4" (110 mm) FPT Connections

Industry leading separation efficiency based on testing to national standards. Comparable operational grease capacity (580 lb) to 750 gallon Gravity GI (Concrete).\* Operation based on Dynamic Inlet Baffle (Pat. Pend.) with internal flow control device. Smart tank design offers many features, with external flow control available as an option. Cut-to-length riser system for burial up to 72", pre-plumbed outlet system, traffic rated dual cover format for unrivalled maintenance accessibility & inspection.



### EnduraXL 100GPM Models

40100A04 - 100GPM (6.3 L/Sec) 4" (110 mm) Connections  
40100A04T - 100GPM (6.3 L/Sec) 4" (110 mm) FPT Connections

Industry leading separation efficiency based on testing to national standards. Comparable operational grease capacity (1058 lb) to 1500 gallon Gravity GI (Concrete).\* Operation based on Dynamic Inlet Baffle (Pat. Pend.) with internal flow control device. Smart tank design offers many features, with external flow control available as an option. Cut-to-length riser system for burial up to 72", pre-plumbed outlet system, traffic rated dual cover format for unrivalled maintenance accessibility & inspection.

\* based on 25% rule for maintenance

# Grease Interceptors – Generic Types

The grease management industry has developed significantly in the past decade with not only more advanced and improved products but also development of performance standards and harmonization of common terms and references.

**Traditionally the term “Grease Trap” was commonly applied and is still used in the industry today. This term is progressively disappearing from nomenclature and technical references based on an industry wide recognition that the term “trap” would suggest the presence of a water seal, integrally located within the interceptor. This practice substantially ceased many years ago, modern interceptors being designed to be installed in conjunction with external water seal traps as a standard part of the system.**

In addition to this clarification, with publication of the 2006 UPC plumbing code three generic types of Grease Interceptor were introduced and have since become the industry standard for designating the type of interceptor being considered.

**Generically the application of a Grease Interceptor regardless of type is defines as follows:**

**Grease Interceptor:** “A plumbing appurtenance or appliance that is installed in a sanitary drainage system to intercept nonpetroleum fats, oil, and grease (FOG) from a wastewater discharge.

**Specific characteristics then define the three types of Interceptor:**

## Hydromechanical Grease Interceptor (HGI)

“An HGI is sized by flow rate (GPM) and qualified separation/retention efficiency, validated against National performance Standards. An HGI incorporates a defined means of flow control, acts to entrain air to influent, includes interior baffling, or barriers in combination or separately, working to promote hydromechanical separation. HGIs are generally installed inside the facility they serve.”

## Gravity Grease Interceptor (GGI)

“A GGI is characterized by volume, minimum 30 minute retention time, baffle(s), not less than two compartments, a total volume of not less than 300 gallons (1135 L), and gravity separation. If not recognized by an official body, a GGI will be designed by a registered professional engineer. GGI's are generally installed outside the building they serve and buried below grade.”











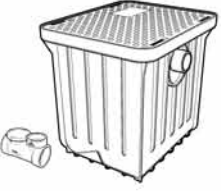

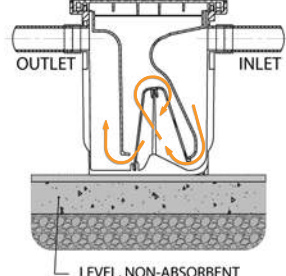
## Grease removal Device (GRD)



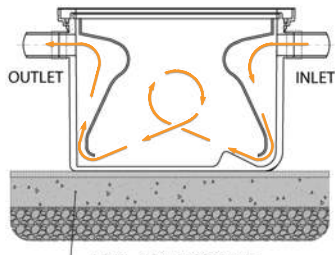
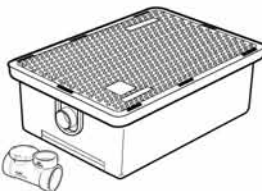

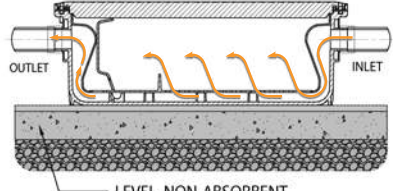
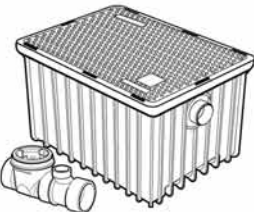

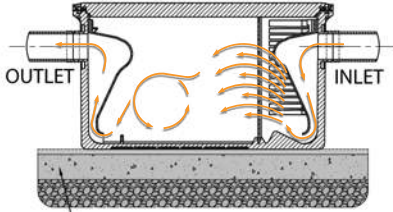
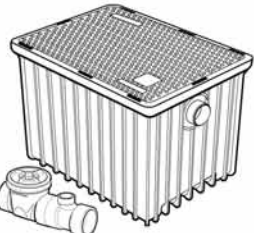

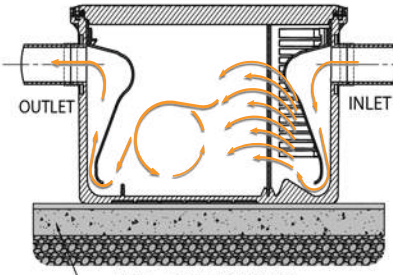

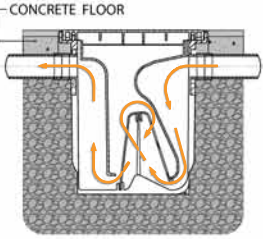





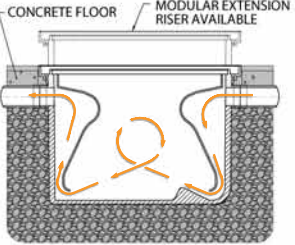
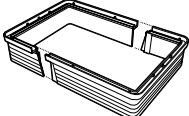
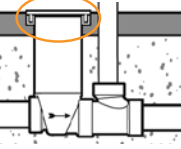











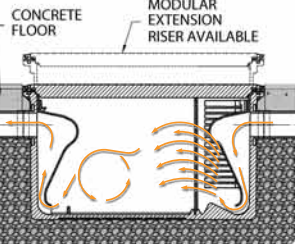
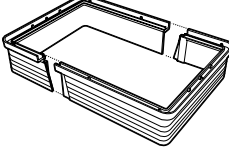
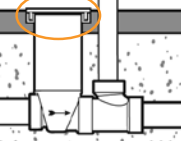

A GRD is a hydromechanical grease interceptor that mechanically removes non-petroleum fats, oils and grease (FOG) from the separation chamber, the control of which is either automatic or manually initiated and involves maintaining liquefied state of intercepted FOG by heating. GRD's are installed inside the facility they serve.”

# Hydromechanical Grease Interceptor VS. Other Grease Interceptors

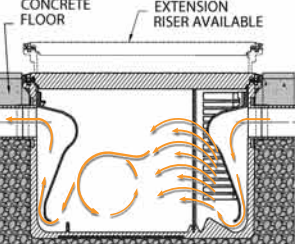
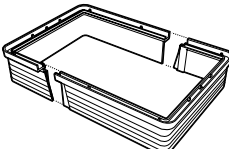
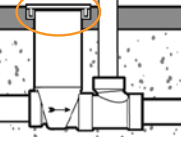
	Canplas Endura (HGI)		Hydromechanical Grease Interceptors (HGI)	Gravity Grease Interceptors (GGI)	Grease Removal Device (GRD)
	7-50gpm	75-100gpm			
<b>National Performance Standards</b>	- PDI G101 - CSA B481 - ASME A112.14.3	- PDI-G101 - CSA B481 - ASME A112.14.3 (Type A/C)	- PDI-G101 - CSA B481 - ASME A112.14.3	None	- PDI-G101 - CSA B481 - ASME A112.14.4
<b>Plumbing Code Approvals/Listing</b>	- UPC - IPC - NPCC - NSPC	- UPC - IPC - NPCC - NSPC	- UPC - IPC - NPCC - NSPC	- UPC (500 USG+) - IPC (300 USG+) - NPCC - NSPC	- UPC - IPC
<b>Specific AHJ Approval</b>	Typically Not	Typically Not	Typically Not	Yes	Yes
<b>Material</b>	Plastic (PP- Polypropylene)	Plastic (PE/PP)- Polyethylene/ Polypropylene)	- Cast Iron - Epoxy Coated Steel - Plastic (PE)	- GRP/Fiberglass - Concrete - Steel	Stainless Steel
<b>Efficiency</b>	93%-99% - Based on ASME A112.14.3 - Tested to breakdown	98%-99% - Based on ASME A112.14.3 - Tested to breakdown	Min 90% (based on Performance Standards)	No Assessment Possible	Min 90% (based on Performance Standards)
<b>Average Lifespan</b>	Min 20 years - Typically life of system	Min 20 years - Typically life of system	- Cast Iron (10-15 yrs) - Epoxy Coated Steel (3-5yrs) - Plastic (PE) (20yrs +)	- GRP/Fiberglass (20yrs+) - Concrete (8-10yrs) - Steel (7-12yrs)	- Tank (10yrs+) - Mechanical (1-3yrs)
<b>Managed Flow</b>	Yes - with Accessible Flow control	Yes – Internal and External Accessible Flow control	Yes (Required for PDI compliance)	No	Yes
<b>Cost Ratio Index - Product</b>	1	0.6 (vs. GGI) 0.9 (vs. HGI – Traditional Materials) 1-1.2 (vs. Plastic HGI)	.9 - 1.5	8-10	6-8
<b>Annual Operation Cost Ratio (Assumes third party service)</b>	1	0.75 (vs. GGI) 0.9 (vs. HGI – Traditional Materials) 0.9 (vs. Plastic HGI)	1	8-10	0.5-1
<b>Footprint Ratio</b>	1	0.3 (vs. GGI) 0.9-1.2 (vs. HGI – Traditional Materials) 1.1 (vs. Plastic HGI)	1	Min 10	1
<b>Sizing Method</b>	Flow Rate	Flow Rate / Pipe Size	Flow Rate / Pipe Size	Capacity (US Gallons)	Flow Rate / Pipe Size
<b>Typical Installation Time</b>	- On-Floor - 2-3hrs - In Floor - 4-6hrs	- On-Floor - 2-3hrs - In Floor – 4-8hrs	- On-Floor - 2-3hrs - In Floor - 4-8hrs	12-15hrs	2-4hrs
<b>Nature of Installation</b>	- Licensed Plumber - Common tools/practices	- Licensed Plumber/ Ground worker - Earthmoving/ Excavation (below grade)	- Licensed Plumber - Common tools/practices	- Licensed Plumber/ Groundworker - Earthmoving/Excavation	- Licensed Installer - Common tools/practices
<b>Installer Profile</b>	- Licensed Plumber	- Licensed Plumber	- Licensed Plumber	- Licensed Plumber (Hook Up) - Ground worker (Install)	- Licensed Plumber - Licensed Electrician
<b>Product Availability</b>	- Stock Item - National/Regional/ Local Plumbing Wholesale - Restaurant Equipment Distributors	- Stock Item - National/ Regional/ Local Plumbing Wholesale	- National/Regional/ Local Plumbing Wholesale - Restaurant Equipment Distributor	- Local/Regional Manufacturer Direct - Special Order -Regional/Local Plumbing Wholesale	- Manufacturer Direct - Local Representation



Product	Description	Connection Size	Recycled Content	On-Floor
 <p><b>Endura Compact Grease Interceptor</b>            - 7 GPM 3907A02            - 10 GPM 3910A02            - 15 GPM 3915A02C            (Suffix "T" for threaded inlet/outlet connections)</p>	<ul style="list-style-type: none"> <li>- Compact tank / small footprint</li> <li>- Injection molded in proven engineered thermoplastics for strength and durability</li> <li>- EZ-Open cover latches</li> <li>- Odor lock cover gasket</li> <li>- Load rated cover supports up to 440 lb (220kg) of pedestrian and light duty traffic</li> <li>- EZ-Clean exterior tank profile with a non-ribbed section at the lower two inches of the tank</li> <li>- 10 Year Limited Manufacturers Warranty</li> </ul>	- 7 GPM 3907A02 - 2" - 10 GPM 3910A02 - 2" - 15 GPM 3915A02C - 2"  Connected using mechanical joint couplings allowing for use of various piping materials.	Minimum of 5% 	 LEVEL, NON-ABSORBENT MATERIAL FOR EVEN SUPPORT OF TANK
 <p><b>Endura Grease Interceptor</b>            - 20 GPM 3920A02            (Suffix "T" for threaded inlet/outlet connections)</p>	<ul style="list-style-type: none"> <li>- Injection molded in proven engineered thermoplastics for strength and durability</li> <li>- EZ-Open cover latches</li> <li>- Odor lock cover gasket</li> <li>- Load rated cover supports up to 440 lb (220kg) of pedestrian and light duty traffic</li> <li>- 10 Year Limited Manufacturers Warranty</li> </ul>	- 20 GPM 3920A02 - 2"  Connected using mechanical joint couplings allowing for use of various piping materials.	Minimum of 5% 	 LEVEL, NON-ABSORBENT MATERIAL FOR EVEN SUPPORT OF TANK
 <p><b>Endura Low Profile Grease Interceptor</b>            - 25 GPM 3925A02L0            (Suffix "T" for threaded inlet/outlet connections)</p>	<ul style="list-style-type: none"> <li>- 11" in height, ideal for under sink installation</li> <li>- Requires only 6" of clearance for maintenance</li> <li>- Injection molded in proven engineered thermoplastics for strength and durability</li> <li>- EZ-Open cover latches</li> <li>- Odor lock cover gasket</li> <li>- EZ-Clean tank exterior</li> <li>- 10 Year Limited Manufacturers Warranty</li> </ul>	- 25 GPM 3925A02L0 - 2"  Connected using mechanical joint couplings allowing for use of various piping materials.	Minimum of 5% 	 LEVEL, NON-ABSORBENT MATERIAL FOR EVEN SUPPORT OF TANK
 <p><b>Endura Grease Interceptor</b>            - 25 GPM 3925ALT02 - 35 GPM 3935A03            - 25 GPM 3925ALT03 - 35 GPM 3935A04            (Suffix "T" for threaded inlet/outlet connections - 3925ALT03 / 3935A03 only)</p>	<ul style="list-style-type: none"> <li>- Injection molded in proven engineered thermoplastics for strength and durability</li> <li>- EZ-Open cover latches</li> <li>- Odor lock cover gasket</li> <li>- Load rated cover supports up to 440 lb (220kg) of pedestrian and light duty traffic</li> <li>- 10 Year Limited Manufacturers Warranty</li> <li>- Supplied with 2 piece flow control</li> </ul>	- 25 GPM 3925ALT02 - 2" - 25 GPM 3925ALT03 - 3" - 35 GPM 3935A03 - 3" - 35 GPM 3935A04 - 4"  Connected using mechanical joint couplings allowing for use of various piping materials.	Minimum of 5% 	 LEVEL, NON-ABSORBENT MATERIAL FOR EVEN SUPPORT OF TANK
 <p><b>Endura Grease Interceptor</b>            - 50 GPM 3950A03            - 50 GPM 3950A04            (Suffix "T" for threaded inlet/outlet connections - 3950A03 only)</p>	<ul style="list-style-type: none"> <li>- Injection molded in proven engineered thermoplastics for strength and durability</li> <li>- EZ-Open cover latches</li> <li>- Odor lock cover gasket</li> <li>- Load rated cover supports up to 440 lb (220kg) of pedestrian and light duty traffic</li> <li>- 10 Year Limited Manufacturers Warranty</li> <li>- Supplied with 2 piece flow control</li> </ul>	- 50 GPM 3950A03 - 3" - 50 GPM 3950A04 - 4"  Connected using mechanical joint couplings allowing for use of various piping materials.	Minimum of 5% 	 LEVEL, NON-ABSORBENT MATERIAL FOR EVEN SUPPORT OF TANK

In-Floor	Extension Riser	Flow Control Extension	Standards Conformance	Listings	Thermal Capability	Remarks
 <p>CONCRETE FLOOR</p> <ul style="list-style-type: none"> <li>• Check local codes for acceptance of in-floor installation</li> <li>• Finish to floor level accommodating requisite materials, E.G. Tile, mortar, etc.</li> </ul>	N/A	N/A	    <p>* Excluding 7 GPM</p>	<p>NYC Commonwealth of Massachusetts</p>   <p>MEA 160-08-E</p>	Continuous discharge at 104°C (220°F)	<p>3-Part Master Format Specifications, CAD drawings &amp; BIM drawings available at <a href="http://ARCAT.com">ARCAT.com</a></p> <p>Installation Guide available at <a href="http://endurainterceptor.com">endurainterceptor.com</a></p>
 <p>CONCRETE FLOOR MODULAR EXTENSION RISER AVAILABLE</p> <ul style="list-style-type: none"> <li>• Finish to floor level accommodating requisite materials, E.G. Tile, mortar, etc.</li> </ul>	 <p><b>6" Modular riser</b></p> <ul style="list-style-type: none"> <li>- Measurement markings</li> <li>- Stackable up to 3 sets (18" Total)</li> <li>- 3920AX6</li> </ul>	 <p><b>Sleeve kit for 3" model only, allows access to in-floor flow control device</b></p> <p>Custom length of SDR 35 or SDR 28 sewer pipe to be used for access sleeve</p> <ul style="list-style-type: none"> <li>- 3" 392203W, 6" SDR 35/28 sewer pipe diameter</li> </ul>	   	<p>NYC Commonwealth of Massachusetts</p>   <p>MEA 160-08-E</p>	Continuous discharge at 104°C (220°F)	<p>3-Part Master Format Specifications, CAD drawings &amp; BIM drawings available at <a href="http://ARCAT.com">ARCAT.com</a></p> <p>Installation Guide available at <a href="http://endurainterceptor.com">endurainterceptor.com</a></p>
<p><b>On-Floor Installation Only</b></p>	N/A	N/A	   	<p>NYC Commonwealth of Massachusetts</p>   <p>MEA 160-08-E</p>	Continuous discharge at 104°C (220°F)	<p>3-Part Master Format Specifications, CAD drawings &amp; BIM drawings available at <a href="http://ARCAT.com">ARCAT.com</a></p> <p>Installation Guide available at <a href="http://endurainterceptor.com">endurainterceptor.com</a></p>
 <p>CONCRETE FLOOR MODULAR EXTENSION RISER AVAILABLE</p> <ul style="list-style-type: none"> <li>• Finish to floor level accommodating requisite materials, E.G. Tile, mortar, etc.</li> </ul>	 <p><b>6" Modular riser</b></p> <ul style="list-style-type: none"> <li>- Measurement markings</li> <li>- Stackable up to 3 sets (18" Total)</li> <li>- 3935AX6</li> </ul>	 <p><b>Sleeve kit allows access to in-floor flow control device</b></p> <p>Custom length of SDR 35 or SDR 28 sewer pipe to be used for access sleeve</p> <ul style="list-style-type: none"> <li>- 3" 392203W, 6" SDR 35/28 sewer pipe diameter</li> <li>- 4" 392204W, 8" SDR 35/28 sewer pipe diameter</li> </ul>	   	<p>NYC Commonwealth of Massachusetts</p>   <p>MEA 160-08-E</p>	Continuous discharge at 104°C (220°F)	<p>3-Part Master Format Specifications, CAD drawings &amp; BIM drawings available at <a href="http://ARCAT.com">ARCAT.com</a></p> <p>Installation Guide available at <a href="http://endurainterceptor.com">endurainterceptor.com</a></p>
 <p>CONCRETE FLOOR MODULAR EXTENSION RISER AVAILABLE</p> <ul style="list-style-type: none"> <li>• Finish to floor level accommodating requisite materials, E.G. Tile, mortar, etc.</li> </ul>	 <p><b>6" Modular riser</b></p> <ul style="list-style-type: none"> <li>- Measurement markings</li> <li>- Stackable up to 3 sets (18" Total)</li> <li>- 3935AX6</li> </ul>	 <p><b>Sleeve kit allows access to in-floor flow control device</b></p> <p>Custom length of SDR 35 or SDR 28 sewer pipe to be used for access sleeve</p> <ul style="list-style-type: none"> <li>- 3" 392203W, 6" SDR 35/28 sewer pipe diameter</li> <li>- 4" 392204W, 8" SDR 35/28 sewer pipe diameter</li> </ul>	   	<p>NYC Commonwealth of Massachusetts</p>   <p>MEA 160-08-E</p>	Continuous discharge at 104°C (220°F)	<p>3-Part Master Format Specifications, CAD drawings &amp; BIM drawings available at <a href="http://ARCAT.com">ARCAT.com</a></p> <p>Installation Guide available at <a href="http://endurainterceptor.com">endurainterceptor.com</a></p>

# Dimensions

## Endura® 7GPM - 10GPM - 15GPM Models

**3907A02** 7GPM (0.44 LPS)

2" (51mm) connection

**3910A02** 10GPM (0.63 LPS)

2" (51mm) connection

**3915A02C** 15GPM (0.94 LPS)

2" (51mm) connection

Notes: ACCESSIBLE FLOW CONTROL DEVICE (FCD) IS SUPPLIED FOR INSTALLATION UPSTREAM OF THE GREASE INTERCEPTOR (GI) - 2" INLET/OUTLET MODELS

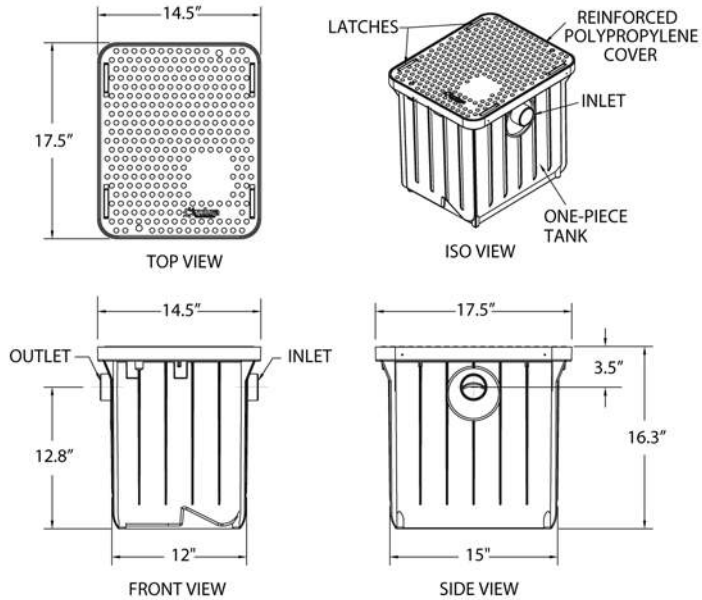
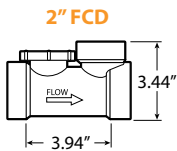

## Endura® 20GPM Models

**3920A02** 20GPM (1.26 LPS)

2" (51mm) connection

Notes: ACCESSIBLE FLOW CONTROL DEVICE (FCD) IS SUPPLIED FOR INSTALLATION UPSTREAM OF THE GREASE INTERCEPTOR (GI) - 2" INLET/OUTLET MODELS

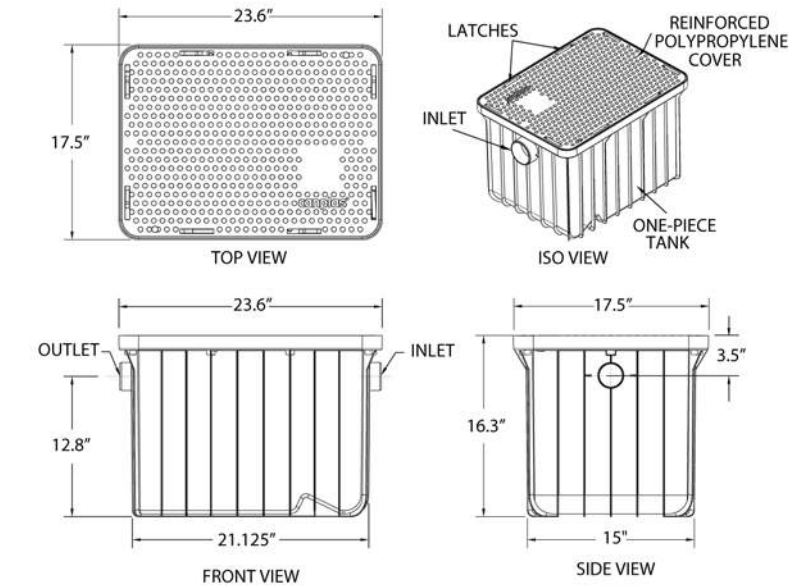
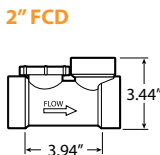

## Endura® Lo-PRO Grease Interceptor 25GPM Model

**3925A02LO** 25GPM (1.6 LPS)

2" (51mm) connection

Notes: ACCESSIBLE FLOW CONTROL DEVICE (FCD) IS SUPPLIED FOR INSTALLATION UPSTREAM OF THE GREASE INTERCEPTOR (GI) - 2" INLET/OUTLET MODEL

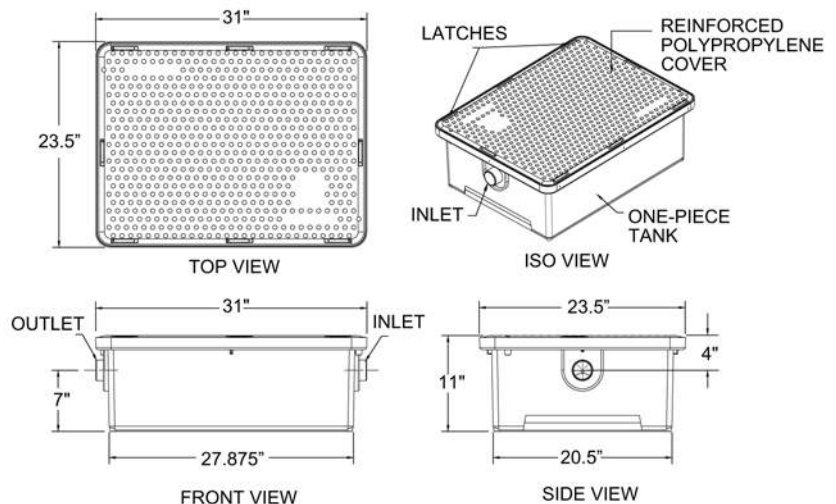
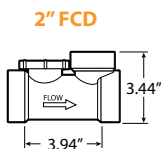



## Endura® 25GPM - 35GPM Models

**3925ALT02** 25GPM (1.6 LPS)  
2" (51mm) connection

**3925ALT03** 25GPM (1.6 LPS)  
3" (76mm) connection

**3935A03** 35GPM (2.2 LPS)  
3" (76mm) connection

**3935A04** 35GPM (2.2 LPS)  
4" (110 mm) connection

### 2" FCD

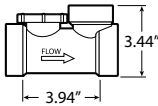

### 3" FCD

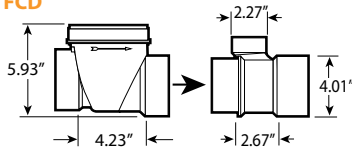

### 4" FCD

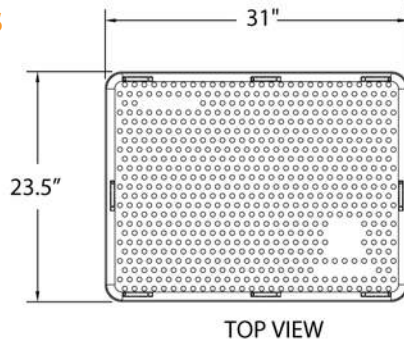
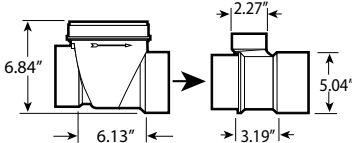

TOP VIEW

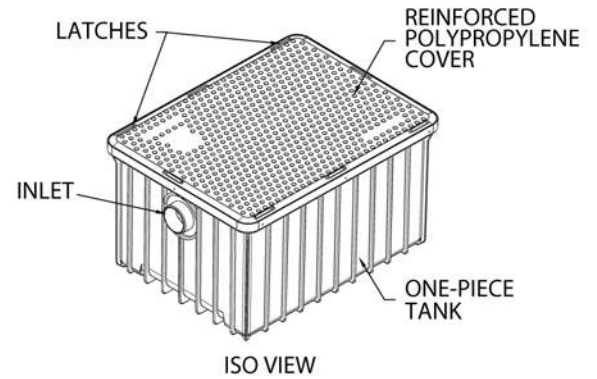

ISO VIEW

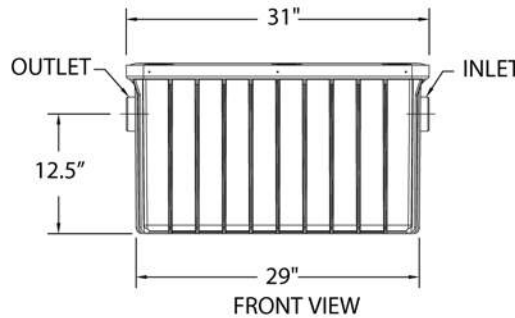

FRONT VIEW

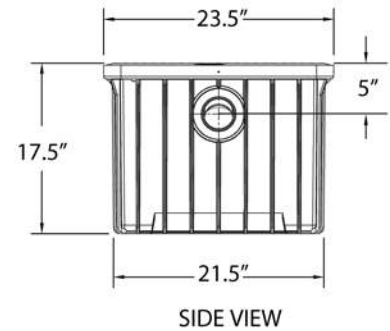

SIDE VIEW

Notes: ACCESSIBLE FLOW CONTROL DEVICE (FCD) IS SUPPLIED FOR INSTALLATION UPSTREAM OF THE GREASE INTERCEPTOR (GI) - 2", 3" or 4" INLET/OUTLET MODELS

## Endura® 50GPM Models

**3950A03** 50GPM (3.2 LPS)  
3" (76 mm) connection

**3950A04** 50GPM (3.2 LPS)  
4" (110 mm) connection

Notes: ACCESSIBLE FLOW CONTROL DEVICE (FCD) IS SUPPLIED FOR INSTALLATION UPSTREAM OF THE GREASE INTERCEPTOR (GI) - 3" or 4" INLET/OUTLET MODELS

### 3" FCD

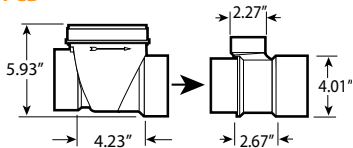

### 4" FCD

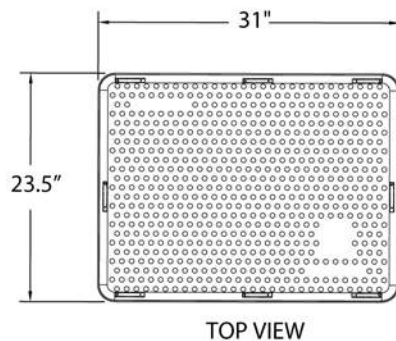
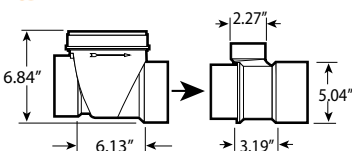

TOP VIEW

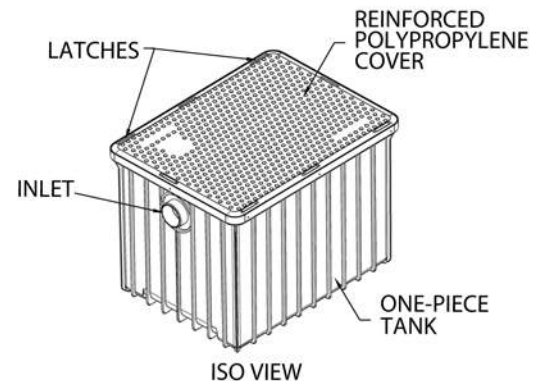



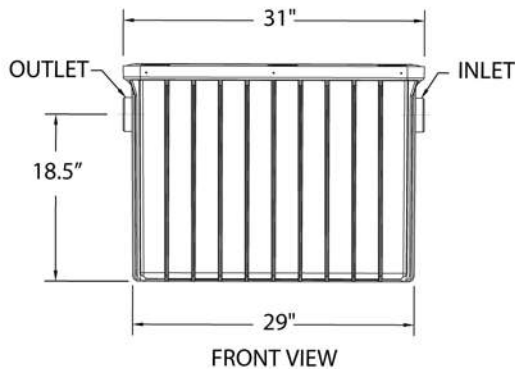

ISO VIEW

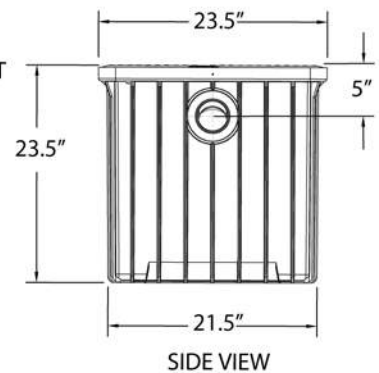

FRONT VIEW

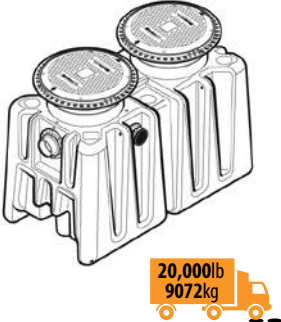

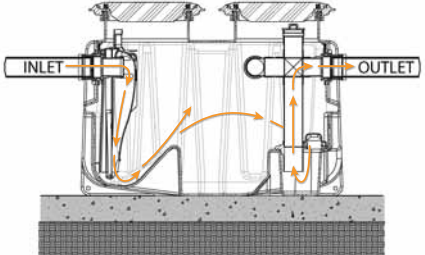
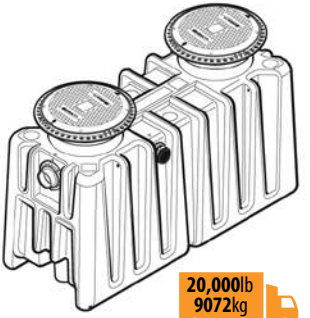
SIDE VIEW

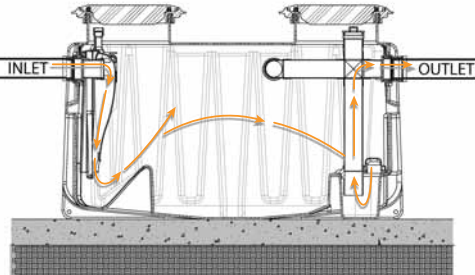
Product	Description	Connection Size	Recycled Content	On-Floor
 <p><b>Endura XL Grease Interceptor</b> -XL75 – 75GPM 4075A04(T)</p>	<ul style="list-style-type: none"> <li>- 559lb Grease Capacity – 98% Efficiency</li> <li>- Dynamic Inlet Baffle – Internal flow Control (Supplied Standard)</li> <li>- Optional External flow control (PDI G101)</li> <li>- Seamless Tank – Rotationally moulded using up to 100% recompounded material</li> <li>- Dual Access Covers -Traffic Rated (CSA B481.1 Type 'S') Rated in excess of 20,000lb (9072kg)</li> <li>- Airtight/Watertight cover, frame and adjustable riser system</li> <li>- Limited Lifetime Warranty</li> </ul>	Inlet - 4" Sch40 DWV Outlet – 4" Sch40 DWV FTP 4" Optional for Inlet & Outlets Outlet (Side) – 4" SDR35 Sewer	 Up to 100%	
 <p><b>Endura XL Grease Interceptor</b> -XL100 – 100GPM 40100A04(T)</p>	<ul style="list-style-type: none"> <li>- 1058lb Grease Capacity – 99% Efficiency</li> <li>- Dynamic Inlet Baffle – Internal flow Control (Supplied Standard)</li> <li>- Optional external flow control (PDI G101)</li> <li>- Seamless Tank – Rotationally moulded using up to 100% recompounded material</li> <li>- Dual Access Covers -Traffic Rated (CSA B481.1 Type 'S') Rated in excess of 20,000lb (9072kg)</li> <li>- Airtight/Watertight cover, frame and adjustable riser system</li> <li>- Limited Lifetime Warranty</li> </ul>	Inlet - 4" Sch40 DWV Outlet – 4" Sch40 DWV FTP 4" Optional for Inlet & Outlets Outlet (Side) – 4" SDR35 Sewer	 Up to 100%	

## Dimensions - XL models

### Endura XL 75GPM Models

**4075A04**  
75GPM (4.74 LPS)  
4" (110 mm) connection

**4075A04T**  
75GPM (4.74 LPS)  
4" (110 mm) threaded connection

Notes: ACCESSIBLE FLOW CONTROL DEVICE (FCD) IS SUPPLIED FOR INSTALLATION UPSTREAM OF THE GREASE INTERCEPTOR (GI) -4" INLET/OUTLET MODELS

#### 4" External FCD

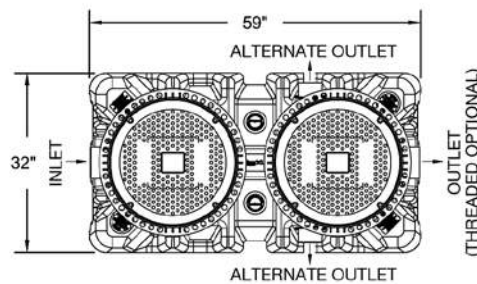
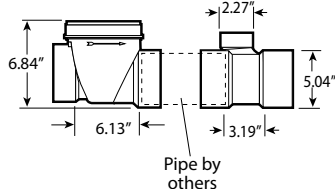

TOP VIEW

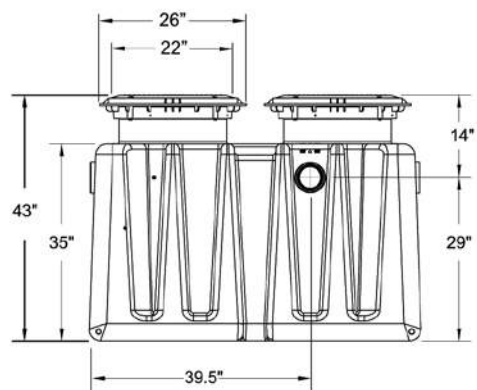

FRONT VIEW

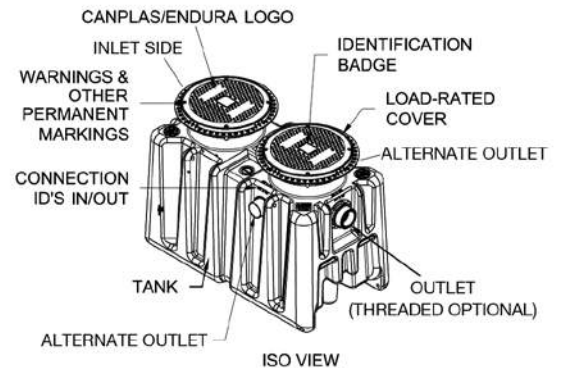



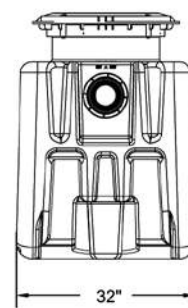





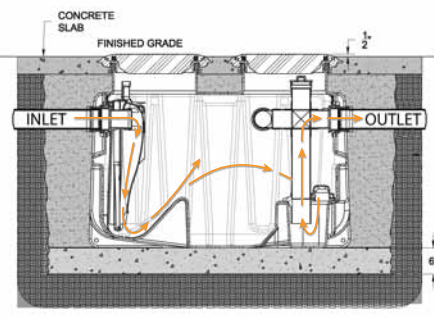

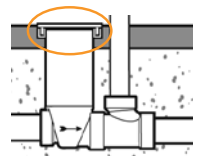



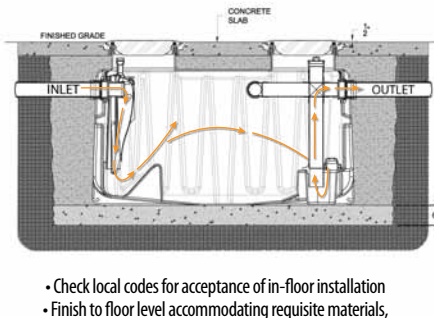

ISO VIEW

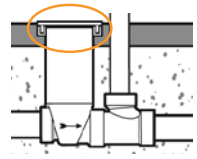

SIDE VIEW



In-Floor	Extension Riser	Flow Control Extension	Standards Conformance	Listings	Thermal Capability	Remarks
 <p>• Check local codes for acceptance of in-floor installation • Finish to floor level accommodating requisite materials, E.G. Tile, mortar, etc.</p>	 <ul style="list-style-type: none"> <li>- 35" 40100AX35</li> <li>- 18" 40100AX18</li> <li>- 35" or 18" Cut-to-length Riser Pairs - Max Extension 72"</li> <li>- Full accessories &amp; instructions supplied</li> <li>- Robust, Airtight, Watertight</li> <li>- 100% recompounded riser</li> <li>- Integral guidelines for cutting</li> </ul>	 <p><b>Sleeve kit for 4" model only, allows access to in-floor flow control device</b> Custom length of 6" Dia. SDR 35 or SDR 28 sewer pipe to be used for access sleeve (Supplied by others) - 4" 392204W</p>	 G-101  C US U.P. Code ASME A12.14.3 & CSA B481.1 	<p>Commonwealth of Massachusetts</p>  	<p>Prolonged intermittent discharge at 71°C (160°F)</p>	<p><b>3-Part Master Format Specifications, CAD drawings &amp; BIM drawings</b> available at <a href="http://ARCAT.com">ARCAT.com</a></p> <p><b>Installation Guide</b> available at <a href="http://endurainterceptor.com">endurainterceptor.com</a></p>
 <p>• Check local codes for acceptance of in-floor installation • Finish to floor level accommodating requisite materials, E.G. Tile, mortar, etc.</p>	 <ul style="list-style-type: none"> <li>- 35" 40100AX35</li> <li>- 18" 40100AX18</li> <li>- 35" or 18" Cut-to-length Riser Pairs - Max Extension 72"</li> <li>- Full accessories &amp; instructions supplied</li> <li>- Robust, Airtight, Watertight</li> <li>- 100% recompounded riser</li> <li>- Integral guidelines for cutting</li> </ul>	 <p><b>Sleeve kit for 4" model only, allows access to in-floor flow control device</b> Custom length of 6" Dia. SDR 35 or SDR 28 sewer pipe to be used for access sleeve (Supplied by others) - 4" 392204W</p>	 G-101  C US U.P. Code ASME A12.14.3 & CSA B481.1 	<p>Commonwealth of Massachusetts</p>  	<p>Prolonged intermittent discharge at 71°C (160°F)</p>	<p><b>3-Part Master Format Specifications, CAD drawings &amp; BIM drawings</b> available at <a href="http://ARCAT.com">ARCAT.com</a></p> <p><b>Installation Guide</b> available at <a href="http://endurainterceptor.com">endurainterceptor.com</a></p>

## Endura XL 100GPM Models

**40100A04**  
100GPM (6.3 LPS)  
4" (110 mm) connection

**40100A04T**  
100GPM (6.3 LPS)  
4" (110 mm) threaded connection

Notes: ACCESSIBLE FLOW CONTROL DEVICE (FCD) IS SUPPLIED FOR INSTALLATION UPSTREAM OF THE GREASE INTERCEPTOR (GI)  
-4" INLET/OUTLET MODELS

### 4" External FCD

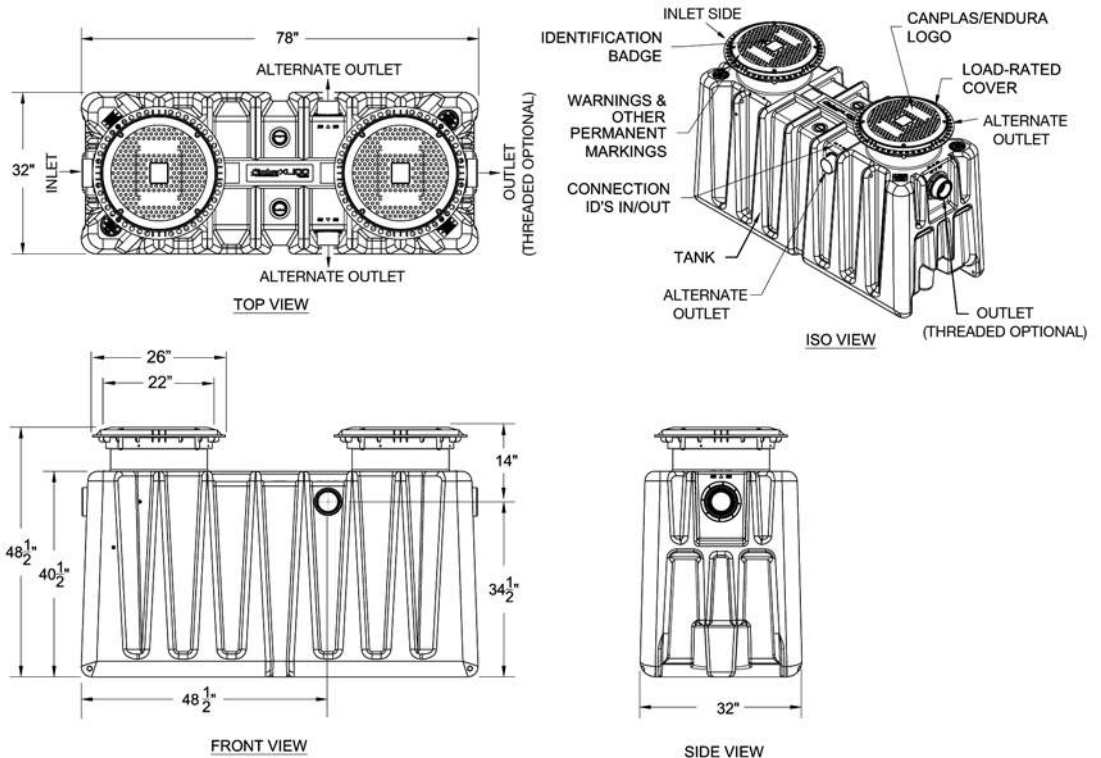
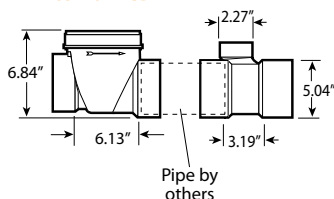

# Key Design Considerations

## Sizing by Flow Rate

Canplas recommends sizing by flow rate for Endura models. The use of a flow control with a Hydromechanical Grease Interceptor is considered **mandatory**. Without a properly sized flow control, the discharge rate through into the interceptor may exceed the design rating of the unit, causing lower efficiencies and increase the risk of grease, passing into the downstream system. Be careful not to confuse liquid capacity and flow rate. Liquid capacity is stated in gallons (or liters) while flow rate is referenced in gallons per minute (GPM) or liters per second (L/Sec).

**Fixture Capacity:** Most commonly used and recommended method for Hydromechanical Grease Interceptors. This method looks at the maximum capacity of fixtures connected to the interceptor and the time taken to discharge that volume of wastewater through the interceptor. Units are expressed in Gallons Per Minute (gpm).

Calculation takes 75% of maximum capacity of all fixtures and based on a 1 or 2 minute period of time taken to discharge, results in a gallons per minute flow rate. This number is rounded up to the next available size of interceptor, i.e. 16.7gpm become a 20gpm Grease Interceptor.

**Table A - Procedure for Sizing Grease Interceptors**

STEP	FORMULA	EXAMPLE
1	<b>Determine cubic content of fixture</b> by multiplying length x width x depth	A sink 24" long by 20" wide by 12" deep. Cubic content: $24 \times 20 \times 12 = 5,760$ cu in ( $61.0 \times 50.8 \times 30.48$ cm <sup>3</sup> )
2	<b>Determine capacity in gallons.</b> 1 gallon = 231 cu in	<b>Contents in gallons:</b> $5,760 / 231 = 24.9$ gallons ( $94,451.42 / 1,000 = 94.45$ litres)
3	<b>Determine actual drainage load.</b>  The fixture is normally filled to approximately 75% of capacity with water as the items being washed displace about 25% of the total fixture content.  Actual drainage load = 75% of fixture capacity	<b>Actual drainage load:</b> $.75 \times 24.9 = 18.7$ gallons ( $0.75 \times 94.45 = 70.84$ litres)
4	<b>Determine flow rate and drainage period.</b> In general, good practice dictates a one minute drainage period; however, where conditions permit, a two minute drainage period is acceptable. Drainage period is defined as the actual time required to completely drain the fixture. Flow rate = $\frac{\text{Actual Drainage Load}}{\text{Drainage Period}}$	<b>Calculate flow rate for one minute drainage period:</b> $18.7 / 1 = 18.7$ g.p.m. flow rate ( $70.84 / 1$ min. = 70.84 l.p.m.) <b>Calculate flow rate for two minute drainage period:</b> $18.7 / 2 = 9.4$ g.p.m. flow rate ( $70.84 / 2$ min. = 35.42 l.p.m.)
5	<b>Select Interceptor.</b> From Table B select the interceptor with a flow rating at least equal to the calculated flow rate. When the calculated flow rate falls between two sizes, select the larger of the two interceptors.	<b>For a one minute drainage period:</b> 18.7 g.p.m. (70.84 l.p.m.) flow rate = 20 g.p.m. G.I. <b>For a two minute drainage period:</b> 9.4 g.p.m. (35.42 l.p.m.) flow rate = 10 g.p.m. G.I.

**Table B -Metric conversions based on PDI sizes**

PDI Size	4	7	10	15	20	25	35	50	75	100
Flow Rate US Gallons per Minute (gpm)	4	7	10	15	20	25	35	50	75	100
Flow Rate Liters per Second (L/Sec)	.25	.44	.63	.95	1.26	1.58	2.20	3.16	4.74	6.3
Grease Capacity Min. (lb)	8	14	20	30	40	50	70	100	150	200
Grease Capacity Min. (kg)	3.63	6.35	9.07	13.61	18.14	22.68	31.75	45.36	68	91

### Pipe Size:

Pipe Diameter	Maximum Flow Rate (gpm)	Size of interceptor 1-minute drain period (gpm)	Size of interceptor 2-minute drain period (gpm)
2-inch	20	20	10
3-inch	60	75	35
4-inch	125	150	75



Visit our website for our easy to use online GI Sizing Calculator.  
[www.EnduraGICalculator.com](http://www.EnduraGICalculator.com)

# Sizing by Capacity

**Capacity:** Based on the volume of wastewater discharge (gallons) into the interceptor expressed as discharge fixture units (DFU's). DFU's are identified in the currently published issue of Uniform Plumbing Code Ch.7 based on occupancy or use.

Fixture	Fixture Units Public	Drainage Fixture Units	Interceptor Volume (min.)
Floor drain, non-emergency	2	8	500
Special purpose sink w/1-1/2" trap	3		
Special purpose sink w/2" trap	4	21	750
Special purpose sink w/3" trap	6		
Commercial sink w/food waste w/1-1/2" trap	3	35	1000
Bar Sink	2		
Mop Sink	3	172	1500
Laundry Sink	2		
		216	2000

**Example:** Commercial sink with food waste with 1-1/2" trap, plus mop sink and special purpose sink 2" trap.

**3+3+3=9 (DFU)**

Referencing table below 9 DFU will require 750 gallon min. interceptor volume.

**Floor Drains & Floor Sinks:** Take the volume of water produced by the number of hose bibs (ie 1.5-2.0 gpm per 3/4" faucet)

**Note:** Capacity sizing is typically applied to gravity grease interceptors (GGI) resulting in a liquid capacity that is substantially greater than an equivalent hydromechanical GI. **An HGI due to its qualified efficiency and grease capacity at breakdown (when efficiency falls below 90%) results in actual grease capacity that is operationally equivalent to a GGI that is 5-6 times that of the HGI.**

# Technical Specifications

Part Number	3907A02	3910A02	3915A02C	3920A02	3925A02L0	3925ALT02 (2") 3925ALT03 (3")	3935A03 (3") 3935A04 (4")	3950A03 (3") 3950A04 (4")	4075A04	40100A04
US Gallons Per Minute - GPM (L/Sec)	7 (0.44)	10 (0.63)	15 (0.94)	20 (1.26)	25 L0 (1.6)	25 (1.6)	35 (2.2)	50 (3.2)	75 (4.74)	100 (6.3)
Grease Capacity Min - lb (kg)	14 (6.35)	20 (9.07)	30 (13.6)	40 (18.1)	50 (22.68)	50 (22.68)	70 (31.8)	100 (45.4)	150 (68.2)	200 (90.8)
Average Efficiency % (ASME A112.14.3)	95.5%	92.5%	92.0%	95.4%	97.1%	98%	98.6%	93.9%	98%	99%
Grease Capacity Actual - lb (kg)	31.95 (14.49)	38.07 (17.28)	40.97 (18.58)	76.4 (34.65)	53.4 (24.22)	*56.25 (25.51)	138.5 (62.8)	*122.07 (55.3)	559 (253)	1058 (480)
Operating Temperature Capabilities	220°F (104°C)	220°F (104°C)	220°F (104°C)	220°F (104°C)	220°F (104°C)	220°F (104°C)	220°F (104°C)	220°F (104°C)	160°F (71°C)	160°F (71°C)
Surface Load Capacity	440 lb (200 kg)	440 lb (200 kg)	440 lb (200 kg)	440 lb (200 kg)	440 lb (200 kg)	440 lb (200 kg)	440 lb (200 kg)	440 lb (200 kg)	20,000 lb (9072 kg)	20,000 lb (9072 kg)
Unit Weight (Empty)	15.8 lb (7.17 kg)	15.8 lb (7.17 kg)	15.8 lb (7.17 kg)	23 lb (10.4 kg)	23.9 lb (10.85 kg)	45 lb (20.4 kg)	45 lb (20.4 kg)	60 lb (27.2 kg)	233 lb (106 kg)	283 lb (128 kg)
Liquid Capacity	12.96 gal (49.06 L)	12.96 gal (49.06 L)	12.96 gal (49.06 L)	21.6 gal (81.8 L)	18.9 gal (71.54L)	39.4 gal (149.1 L)	39.4 gal (149.1 L)	52.0 gal (197 L)	158 gal (598 L)	257 gal (973 L)
Connection size (mechanical joint only)	2"	2"	2"	2"	2"	2" (3925ALT02) 3" (3925ALT03)	3" (3935A03) 4" (3935A04)	3" (3950A03) 4" (3950A04)	4"	4"

\* Not evaluated to breakdown capacity (PDI-G101)

**Grease Capacity Min - lb (kg):** Industry minimum grease capacity based on GPM flow rate. Requires minimum 2 lb of grease capacity for each GPM of flow.

**Grease Capacity Actual - lb (kg):** Actual capacity at breakdown when tested to ASME A112.14.3

# Dimensions - Flow Control Device Assembly



1 Piece Compact Flow Control



2 Piece Flow Controls (3" Version Illustrated)

AIR INTAKE TEE  
on XL models 4" h x h

Connection Iron Pipe Size (Solvent weld)	Flow Control & Air Intake Combined		Flow Control Body			Air Intake Tee		
	Compact 2" h x h		2" h x h	3" h x h	4" h x h	3" spg x h	4" spg x h	XL Models 4" h x h
A	3.94" (100mm)		3" (76.2mm)	4.23" (107.4mm)	6.13" (155.7mm)	2.67" (67.8mm)	3.19" (81mm)	3.19" (81mm)
B	3.44" (87.4mm)		3.84" (97.5mm)	5.93" (151mm)	6.84" (173.7mm)	4.01" (101.9mm)	5.04" (128mm)	5.04" (128mm)
C	-		-	-	-	2.27" (57.7mm)	2.72" (69.1mm)	2.72" (69.1mm)



# Flow Control

Key to hydromechanical function and performance is flow control. If designing for compliance with PDI-G101 an external flow control(s) SHALL be required as part of the design and installation. Where acceptable to the Authority Having Jurisdiction, internal means of flow control can be employed providing that the interceptor is approved to the currently published version of ASME A112.14.3 –Type C or D. Any method of flow control SHALL be accessible once in operation for cleaning and maintenance purposes. The Canplas external flow control device can be recessed into the floor if required. Extension sleeves available. (See Page 5)

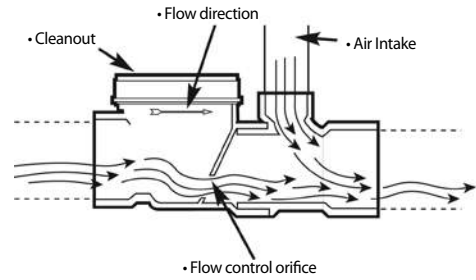

## Flow Control Location – Indirect Connection:

**Where required to be installed as an indirect plumbing system, the initial means of flow control SHALL be installed upstream of the air gap to prevent overflow during fixture/appliance discharge.**



Some local jurisdictions require warewashing installations to be made on an indirect basis incorporating an air gap.

An air gap prevents back up of contaminated water into the sinks/appliances in the event of a system back flow. The flow control device must be incorporated before the indirect connection to prevent overflow occurring during high/maximum waste water discharge. If an air gap is located within 6" of flow control device\*, installation of the air intake tee is optimal. (\*Verify with Authority Having Jurisdiction)

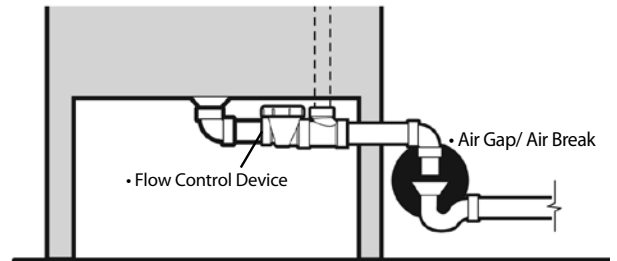

## Flow Control Formats

### External (Supplied Standard up to 50gpm)

Hub x Hub format – Sch40 DWV. Nominal diameters 2"(Compact), 3" and 4". For solvent weld within ABS or PVC DWV drainage systems, use appropriately approved solvent cement.

**NOTE: The Flow Control cannot be solvent welded directly to the interceptor. An appropriately sized pipe stub will be necessary in the event that the FCD is in close proximity to the interceptor, allowing connection only with locally approved Mechanical Joint (MJ) couplings.**



**Compact Version**  
Example: 3922125C  
1 piece format

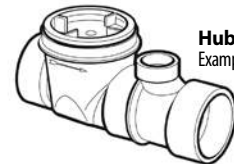

**Hub Version**  
Example: 3933125  
2 piece format  
- 3" & 4" models  
(2" available)



**Spigot Version**  
Example: 3933125AS  
2 piece format  
- 3" & 4" models  
(2" available)

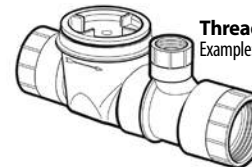

**Threaded Version**  
Example: 3933125AT  
2 piece format  
- 3" & 4" models  
(2" available)

### Spigot (Suffix 'S')

Supplied with Spigot format connections for installation with locally approved Mechanical Joint (MJ) couplings.

### Threaded (Suffix 'T')

Supplied with Female Pipe Thread (FPT) connections. Installed to Male Pipe Thread (MPT) using appropriate (PTFE) thread sealing tape.

### Internal (Supplied Standard 75/100gpm)

On models 4075A04(T) and 40100A04(T) the internal flow control is located inside the dynamic inlet baffle, affixed to the downstream part that moves forward when the baffle is opened. This maintains full accessibility when operational.

NOTE: Internal flow control plate will only be removed when replaced with an external equivalent of the correct flow rate. Floor below installation can use the internal flow control as the secondary flow control, the primary flow control being installed externally as close as possible to fixtures.

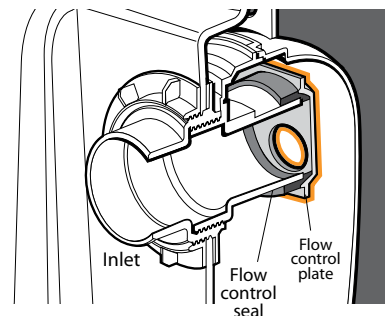

**The installation of a ball valve upstream of the flow control is recommended. A ball valve provides a means of drain line isolation for maintenance.**

Some local plumbing codes require that grease interceptors have an internal flow control to ensure drain lines do not bypass the grease interceptor. However, if the flow control device is located immediately upstream of an interceptor, this is often considered as forming part of the interceptor. Please contact your local representative if you require further clarification.

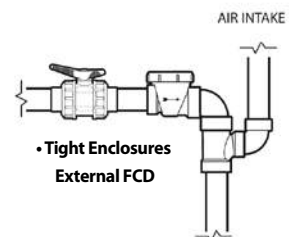
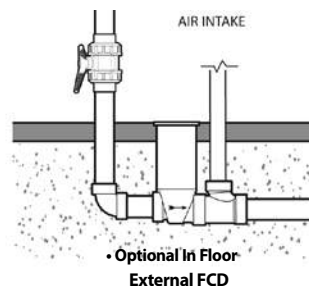
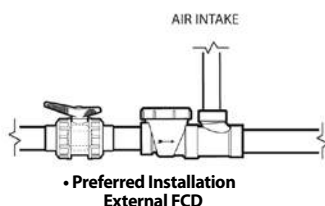

## Tank Connections

**All Endura Grease Interceptors are manufactured with standard no hub connections to accept locally approved/accepted MJ (Mechanical Joint) couplings.**

This method allows resilience in the connections to prevent stress and a flexible means of integrating metallic or plastic plumbing systems. Should adaption of pipe connection be required, use appropriate mechanical joint reducers but do not allow decrease pipe diameter across the unit. (i.e. 3" inlet, 2" outlet.)

Due to regional and local code variation, models with threaded connections (FPT) are available by adding suffix 'T' to the part number. Both tank and flow control (TFCD) will be supplied with FPT connections in this instance based on the respective nominal pipe size. Likewise Endura Interceptors can be supplied with spigot format flow controls (SFCD) by adding suffix 'S' to the part number.

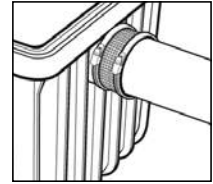
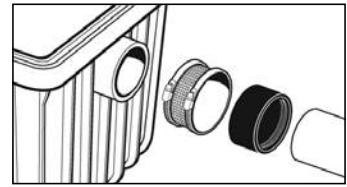

**Note: Solvent cement is not an acceptable jointing method from the piping system to the interceptor. This will result in leakage.**

## Connection of Dishwashing Systems

Dependent on the Authority Having Jurisdiction (AHJ), a dishwashing system may be required or prohibited from discharging to the grease interceptor. Verify with the respective AHJ. Best practice recommends that where a dishwashing system is required to be connected to the interceptor, that it be serviced by a separate and appropriately sized interceptor, the outlet being connected to the building drain downstream of the main interceptor.

Where not specified, the dishwashing system is recommended to bypass the grease interceptor, the outlet being connected downstream of the interceptor outlet. This is based evidentially on the negative impact of commercial detergents and surfactants that are specifically designed to emulsify fats oil and grease making it virtually impossible to separate this material from waste water discharge. If discharged to the interceptor, the same agents will likewise cause even the most efficient interceptor, regardless of generic type to work at a significantly reduced efficiency, passing FOG to the downstream system.

## Air-Balanced Operation

A hydromechanical grease interceptor is designed to operate as an air balanced environment. This is vital to the function of the interceptor and as such no modification or removal of any component parts should be made before, during or after installation unless specifically addressed in the respective Installation & Operation document.

## Venting

Unlike Gravity Grease Interceptors, a Hydromechanical Grease Interceptor tank is not required to be directly vented. This would be detrimental to the function of the interceptor. All connected appliances shall be individually trapped and vented in accordance with local code requirements. The downstream drain carrying effluent to the municipal wastewater system shall also be vented to atmosphere in compliance with applicable code.

## Drain Cleanouts

For installations below grade, most codes require the installation of a two way cleanout immediately before and after the respective inlet and outlet connections. These cleanouts will be extended to grade so as to remain accessible once the interceptor is operational.

## Head Effect

An installation above or below grade that sees a fall equal to or in excess of 8 ft, when measured from the outlet of the highest appliance to the invert of the interceptor SHALL require the installation of a secondary flow control device to neutralize the effect of head pressure. The first flow control will be located as close as possible to the last appliance discharging to the interceptor, the second being located externally immediately before the interceptor or by utilizing the manufacturers internal flow control device where available. See page 17/18 for reference.

## Accessibility for Maintenance:

All grease interceptors regardless of generic type, require regular maintenance. Any design and subsequent installation shall make due consideration to the provision of access for the same as defined in the respective installation documentation. Canplas installation documents are available for download or reference at [www.endurainterceptor.com](http://www.endurainterceptor.com)

# Typical Installation

## • On Floor

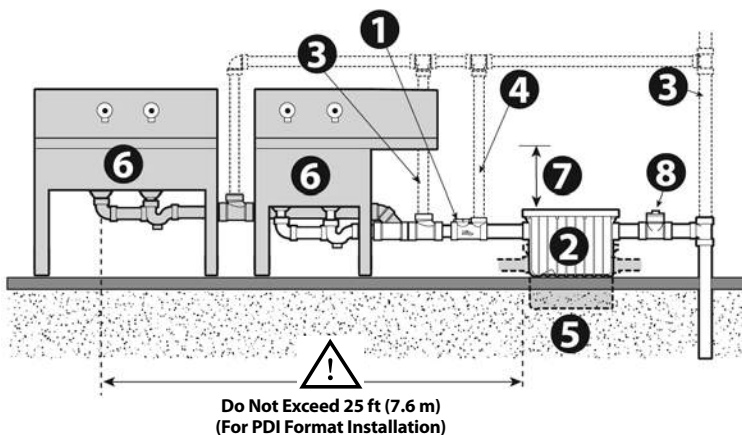

### CAUTION: CLEARANCE REQUIRED

15" clearance (21" for 50GPM model) to remove the baffles for cleaning and maintenance.

- 1 • Flow Control Device
- 2 • Grease Interceptor
- 3 • Vented Waste
- 4 • Air Intake
- 5 • Semi Recessed Option
- 6 • Sink
- 7 • ⚠ Minimum Clearance 15" / 21"
- 8 • Cleanout required in most jurisdictions

## • In Floor

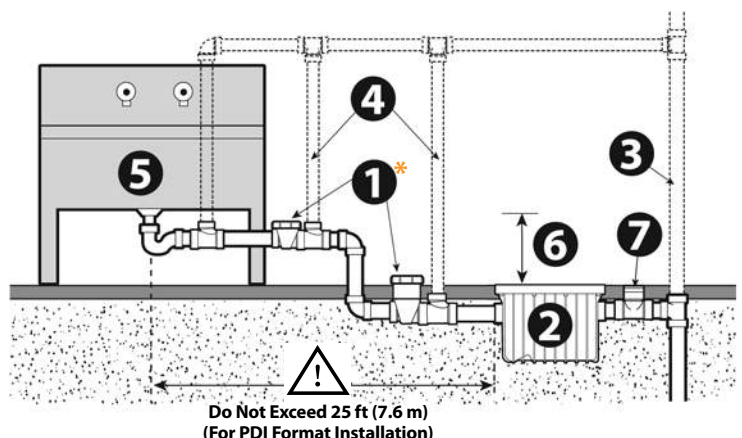

### When backfilling in-floor, the interceptor must have both the cover fitted and be filled with water to the inlet/outlet level.

This will ensure the tank itself will not move during backfilling, pouring and/or floor finishing. When backfilling in particular, care should be taken to do so evenly around the unit and with light manual pressure only.



Ensure that the interceptor is clearly identified to flooring contractors to prevent it from being covered with flooring material. Taping cardboard to the cover is generally effective.



### CAUTION: CLEARANCE REQUIRED

15" clearance (21" for 50GPM model) above the grease interceptor is required to remove the baffles for cleaning and maintenance.

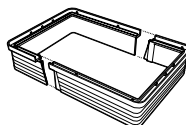

### 6" Modular risers available where deeper installation is necessary to accommodate existing drainage.

- Stackable up to 3 sets (18" Total)
- 3920AX6 (20/25gpm) and 3935AX6 (35/50gpm)

- 1 • Flow Control Device
- 2 • Grease Interceptor
- 3 • Vented Waste
- 4 • Air Intake
- 5 • Sink
- 6 • ⚠ Minimum Clearance 15" / 21"
- 7 • Cleanout required in most jurisdictions

## • In Floor - Extended Capacity

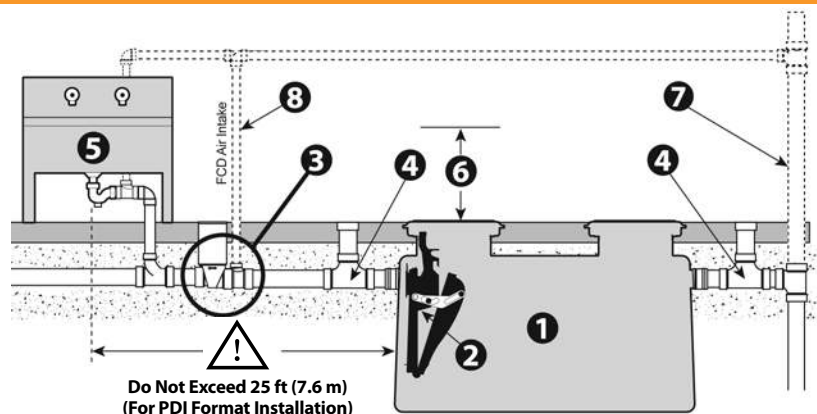

**When backfilling in-floor, the interceptor must have both the cover fitted and be filled with water to the inlet/outlet level.** This will ensure the tank itself will not move during backfilling, pouring and/or floor finishing. When backfilling in particular, care should be taken to do so evenly around the unit and with light manual pressure only.



Ensure that the interceptor is clearly identified to flooring contractors to prevent it from being covered with flooring material. Taping cardboard to the cover is generally effective.



### CAUTION: CLEARANCE REQUIRED

Locate the interceptor so as to allow for accessibility when conducting maintenance and regular cleaning. Set the interceptor on a firm, level surface ensuring tank is equally supported.

### Risers available where deeper installation is necessary to accommodate existing drainage.

- 35" or 18" Cut-to-length Riser Pair - Max Extension 72"
- Full accessories & instructions supplied
- Robust, Airtight, Watertight
- 100% recomounded riser, Integral guidelines for cutting
- PN: 35" - 40100AX35 / 18" - 40100AX18



- 1 • XL Grease Interceptor
- 2 • Internal Flow Control and Baffle
- 3 • External Flow Control (Optional) required for PDI installations
- 4 • Cleanout (recommended)
- 5 • Sink
- 6 • ⚠ CAUTION: CLEARANCE REQUIRED
- 7 • Vented Waste
- 8 • Air Intake



# Low Profile

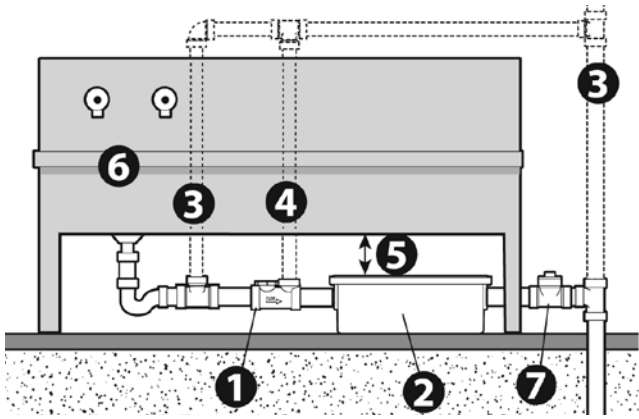

The Endura Lo-PRO is installed on floor. Ensure you design/locate the grease interceptor so as to allow for maintenance. Placement should allow the cover to be easily removed for cleaning. **A minimum clearance of only 6 inches is required above the top of the Grease Interceptor to allow removal of the internal baffles for a complete cleanout.**



### CAUTION: CLEARANCE REQUIRED

6" clearance above the grease interceptor required to remove the baffles for cleaning and maintenance.

- 1 • Flow Control Device
- 2 • Grease Interceptor
- 3 • Vented Waste
- 4 • Air Intake
- 5 • ⚠ Minimum Clearance 6"
- 6 • Sink
- 7 • Cleanout required in most jurisdictions

## • Floor Below - Multiple Fixture Installation

### Typical Installation

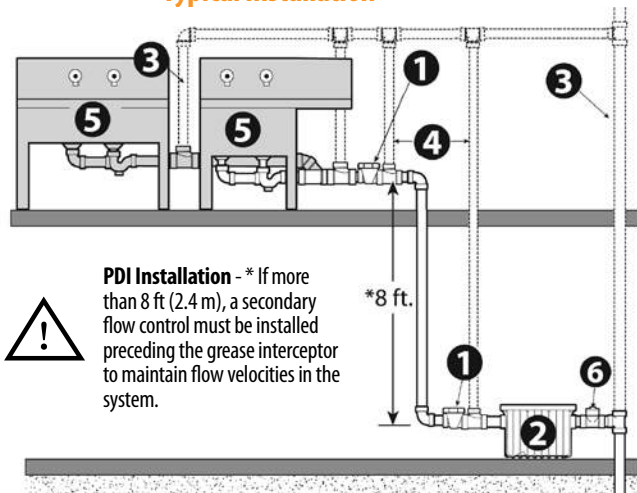

**PDI Installation** - \* If more than 8 ft (2.4 m), a secondary flow control must be installed preceding the grease interceptor to maintain flow velocities in the system.

### Ontario Can. Plumbing Code 7.4.4.3 (9) Typical Installation

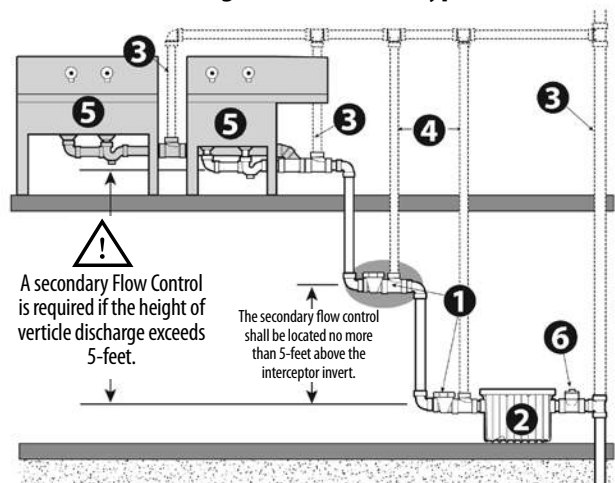

A secondary Flow Control is required if the height of verticle discharge exceeds 5-feet.

The secondary flow control shall be located no more than 5-feet above the interceptor invert.

One interceptor serving multiple fixtures is recommended only when the fixtures are located close together (max 25 ft of developed pipe run). In such installations, each fixture should be individually trapped and back-vented.

- 1 • Flow Control Device
- 2 • Grease Interceptor
- 3 • Vented Waste
- 4 • Air Intake
- 5 • Sink
- 6 • Cleanout required in most jurisdictions

## • Floor Below - Extended Capacity, Multiple Fixture Installation

### Typical Installation

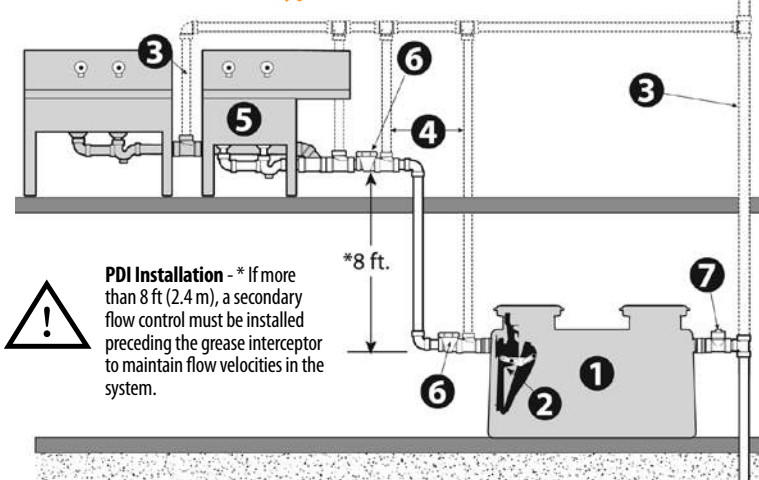

**PDI Installation** - \* If more than 8 ft (2.4 m), a secondary flow control must be installed preceding the grease interceptor to maintain flow velocities in the system.

### Ontario Can. Plumbing Code 7.4.4.3 (9) Typical Installation

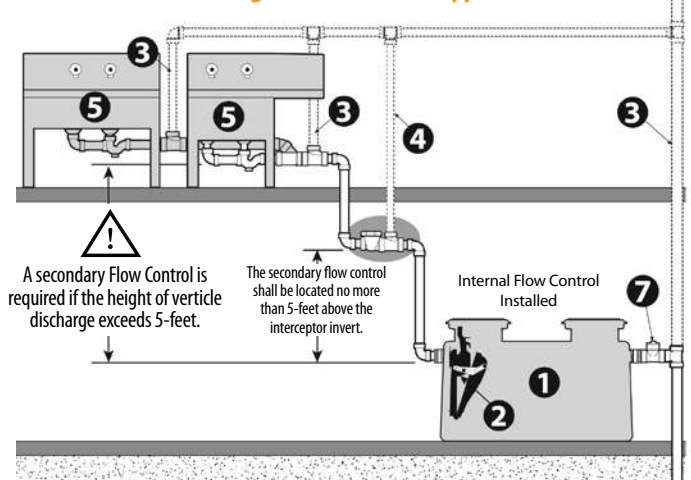

A secondary Flow Control is required if the height of verticle discharge exceeds 5-feet.

The secondary flow control shall be located no more than 5-feet above the interceptor invert.

Internal Flow Control Installed

One interceptor serving multiple fixtures is recommended only when the fixtures are located close together (max 25 ft of developed pipe run). In such installations, each fixture should be individually trapped and back-vented.

- 1 • XL Grease Interceptor
- 2 • Internal Flow Control and Baffle
- 3 • Vented Waste
- 4 • Air Intake
- 5 • Sink
- 6 • External Flow Control (Optional) required for PDI installations (No internal flow control installed)
- 7 • Cleanout required in most jurisdictions

## • In Floor Alternate

### • Fork Lift, Pump Truck Traffic Area

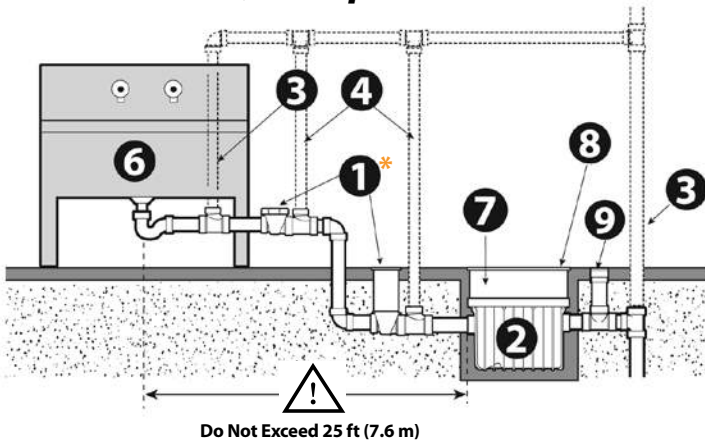

Provision of a concrete pit with a load rated access cover will be required where pump trucks or fork lifts travel.

- 1 • Flow Control Device  
\* Above grade installation preferred
- 2 • Grease Interceptor
- 3 • Vented Waste
- 4 • Air Intake
- 5 • Hanger (Supplier by installer)
- 6 • Sink
- 7 • Concrete pit
- 8 • Load Rated Access Cover (supplied by others)
- 9 • Cleanout required in most jurisdictions

#### Note: XL Extended Capacity Models

EnduraXL models are manufactured with Load Rated covers. See page 17 for installation notes.

## • Suspended

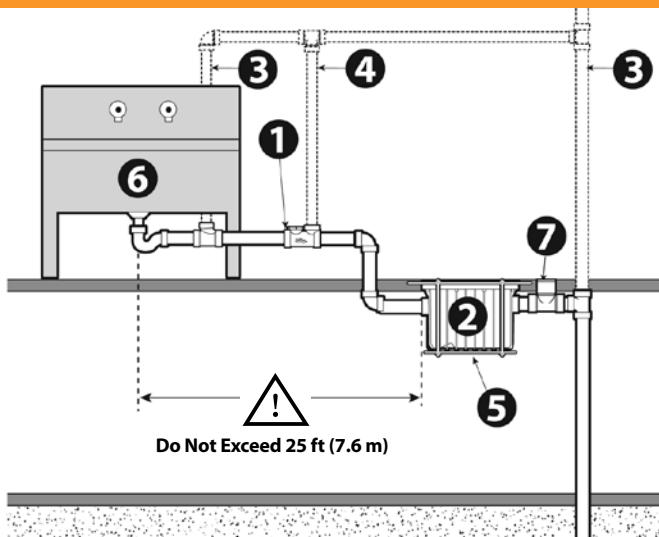

Due to the degree of risk and potential liability for the installer, great care must be taken in designing a hanger system. Canplas recommends consulting an engineer before installing in this manner.

- 1 • Flow Control Device
- 2 • Grease Interceptor
- 3 • Vented Waste
- 4 • Air Intake
- 5 • Hanger (Supplied by installer, designed by licensed engineer)
- 6 • Sink
- 7 • Cleanout required in most jurisdictions



**Hanger must accommodate min. 541 lb (246kg) Safety factor of 2.5 is recommended.**

## • Suspended - Extended Capacity

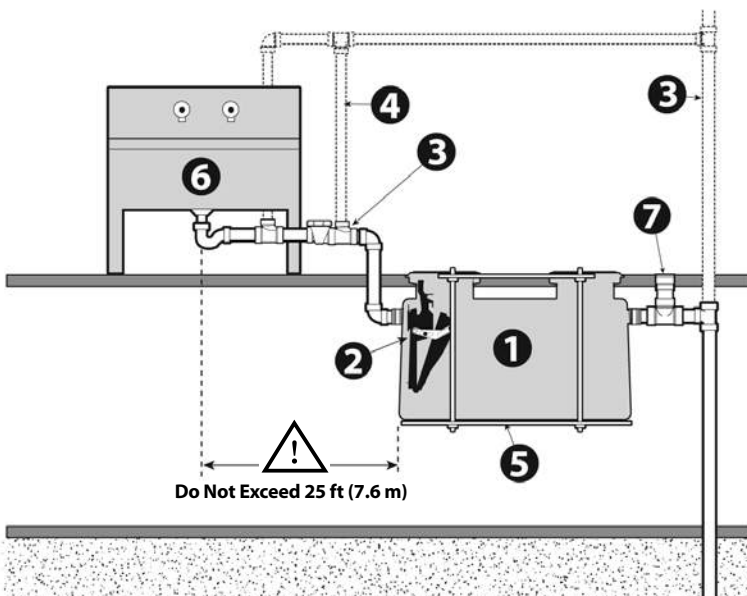

Due to the degree of risk and potential liability for the installer, great care must be taken in designing a hanger system. Canplas recommends consulting an engineer before installing in this manner.

- 1 • XL Grease Interceptor
- 2 • Internal Flow Control and Baffle
- 3 • External Flow Control required for PDI installations
- 4 • Air Intake
- 5 • Hanger (Supplied by installer)
- 6 • Sink
- 7 • Cleanout required in most jurisdictions



**When full the weight of the tank is significant XL75 Approx. 1300lb [590kg], XL100 Approx. 2150lb [975kg]**

**Safety factor of 2.5 is recommended. For suspended application engineering service by a qualified engineer will be necessary.**

# • Interior or Exterior Below Grade Installations - Extended Capacity

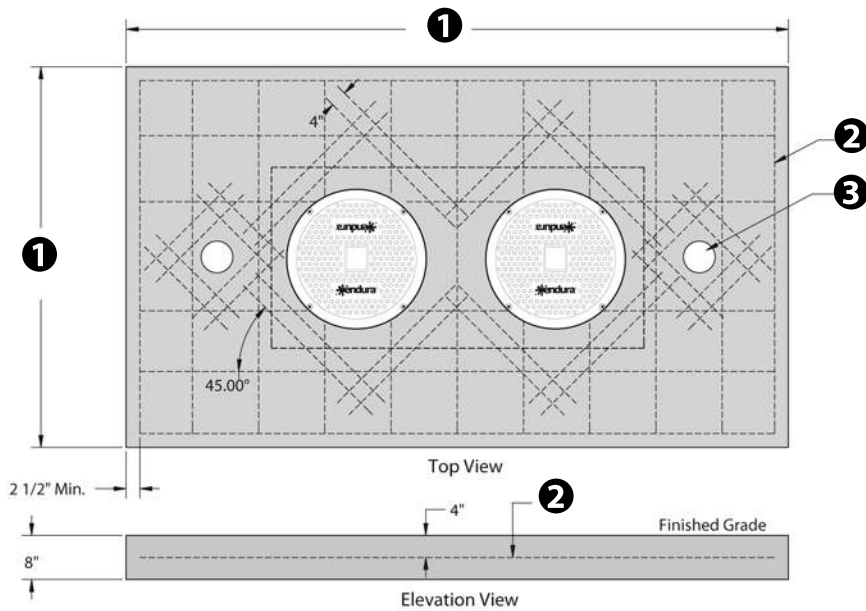

## • Concrete Slab Detail For Traffic Loading

Concrete to be 28 day compressive strength to 4000 PSI. Reinforcement with No.4 rebar (1/2") grade 60 steel per ASTM A615; connected with tie wire. Rebar to be 2 1/2" from edge of concrete. Rebar spacing 12" grid. 4" spacing around access openings.

- ❶ • Concrete Pad must extend min. 18" outside the unit footprint
- ❷ • No.4 rebar (1/2")
- ❸ • 2-Way cleanout tee (414155BC)

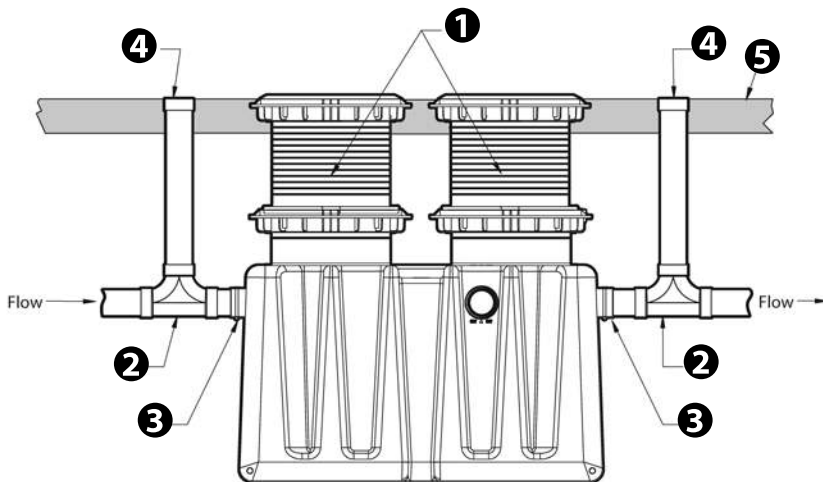

## • Side View Detail For unit details see specification sheet for selected unit

- ❶ • Risers to grade
- ❷ • 2-Way cleanout tee (414155BC)
- ❸ • Standard 4" mechanical joint coupling (by others)
- ❹ • Clean out to grade on outlet pipe of each unit (by others)
- ❺ • Concrete Slab

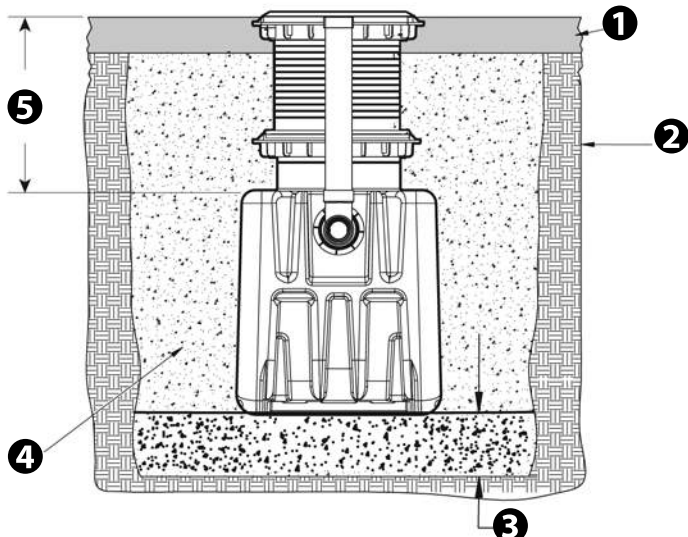

## • Excavation and Backfill Detail

- ❶ • Concrete Slab
- ❷ • Native soil
- ❸ • 6" Min. base crushed aggregate material approx. 3/4" size rock, pea gravel or sand 95 proctor.
- ❹ • Crushed aggregate material approximately 3/4" size rock, pea gravel or sand.
- ❺  • 72" Maximum height



# • Multi-Unit Installations - Extended Capacity

2 no. XL75 – PARALLEL  
Up to 150GPM, 1118 lbs  
Grease Capacity.



2 no. XL100 – PARALLEL  
Up to 200GPM, 2116 lbs  
Grease Capacity.

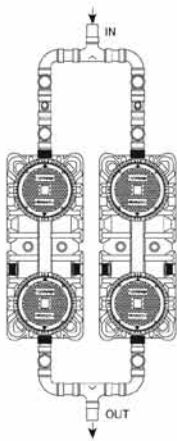

3 no. XL100 – PARALLEL  
Up to 300GPM, 3174 lbs  
Grease Capacity.

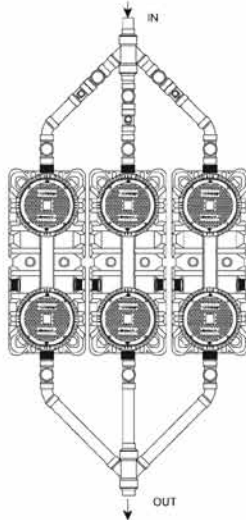

4 no. XL100 – PARALLEL  
Up to 400GPM, 4232 lbs  
Grease Capacity.

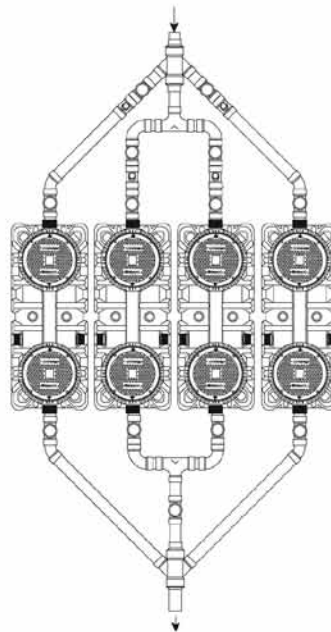

## Parallel Installation:

- Parallel configurations shown are considered optimal for application and should be followed.
- Intended for installations with high flow (greater than 60% of rated flow capacity) per unit.

2 no. XL75 – SERIES - 75GPM, 1118 lbs Grease Capacity.



2 no. XL100 – SERIES - 100GPM, 2116 lbs Grease Capacity.

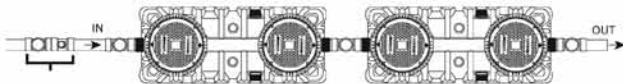

3 no. XL100 – SERIES - 100GPM, 3174 lbs Grease Capacity.

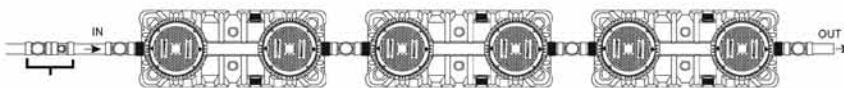

4 no. XL100 – PARALLEL - Up to 400GPM, 4232 lbs Grease Capacity.



4 no. XL100 – PARALLEL - Up to 400GPM,  
4232 lbs Grease Capacity.

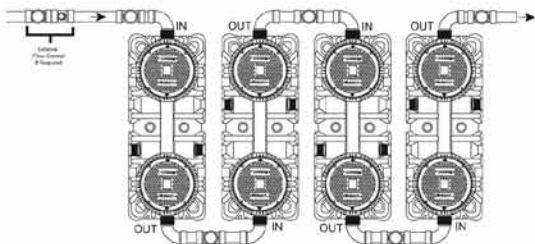

## Series Installation:

- Series configurations shown are considered optimal for application and should be followed
- Anticipated as installations with low to medium flow (less than 60% of rated flow capacity)

For more information on multi-unit installations, please visit the downloads section at [www.enduraxl.com/downloads.html](http://www.enduraxl.com/downloads.html)

# Specifications

**SPEC NOTE:** See [www.arcacat.com](http://www.arcacat.com) website for Microsoft Word (editable) document.

**SPEC NOTE:** Canplas LLC and Canplas Industries Ltd. are members of the Aliaxis Group of companies, a global leader of plastic solutions for fluid transport in the field of building materials. The Aliaxis Group provides products for both residential and commercial building markets, in new build and renovation segments, as well as a wide range of solutions for industrial and public utility applications.

**SPEC NOTE:** Nomenclature  
GPM US Gallons Per Minute  
L/Sec Liters Per Second  
DFU Discharge Fixture Unit

## SECTION 22 13 23

### GREASE INTERCEPTORS

Copyright 2014 - 2015 ARCAT, Inc. - All rights reserved

#### PART 1 GENERAL

##### 1.1 SECTION INCLUDES

- A. Grease interceptors.

##### 1.2 RELATED SECTIONS

- A. Section 23 05 00 - Common Work Results for HVAC.

##### 1.3 REFERENCES

- A. CAN/CSA-B481.1: Testing and Rating of Grease Interceptors using Lard.

##### 1.4 SUBMITTALS

- A. Submit under provisions of Section 01 30 00 - Administrative Requirements.
- B. Product Data: Manufacturer's data sheets on each product to be used, including:
  - 1. Preparation instructions and recommendations.
  - 2. Storage and handling requirements and recommendations.
  - 3. Installation methods.

##### 1.5 QUALITY ASSURANCE

- A. Manufacturer Qualifications: Minimum 5 years experience manufacturing similar products.
- B. Installer Qualifications: Minimum 2 years experience installing similar products.

##### 1.6 PRE-INSTALLATION MEETINGS

- A. Convene minimum two weeks prior to starting Work of this section.

##### 1.7 DELIVERY, STORAGE, AND HANDLING

- A. Deliver and store products in manufacturer's unopened packaging bearing the brand name and manufacturer's identification until ready for installation.
- B. Handling: Handle materials to avoid damage.

##### 1.8 PROJECT CONDITIONS

- A. Maintain environmental conditions (temperature, humidity, and ventilation) within limits recommended by manufacturer for optimum results. Do not install products under environmental conditions outside manufacturer's recommended limits.

##### 1.9 SEQUENCING

- A. Ensure that products of this section are supplied to affected trades in time to prevent interruption of construction progress.

##### 1.10 WARRANTY

- A. Endura Grease and Solids Management as manufactured by Canplas Industries LLC shall be

supported by a 10 year manufacturer's extended warranty.

## PART 2 PRODUCTS

### 2.1 MANUFACTURERS

- A. Acceptable Manufacturer: Canplas Industries Ltd., which is located at: Canada, 500 Veterans Dr. P.O.Box 1800, Barrie, ON, Canada L4M 4V3 Toll Free Tel: 800-461-1771; Tel: 705-726-3361; Fax: 705-726-2186; Email: request info (canplas@canplas.com); Web (corporate): [www.canplas.com](http://www.canplas.com) Web (product): [www.endurainterceptor.com](http://www.endurainterceptor.com)
- B. Substitutions: Not permitted.
- C. Requests for substitutions will be considered in accordance with provisions of Section 01 60 00 - Product Requirements.

### 2.2 GREASE MANAGEMENT

- A. Grease and solids management shall be from a single source of Endura Grease Management products manufactured by Canplas Industries Ltd.

### 2.3 GREASE INTERCEPTORS

#### A. Product: Endura Compact GI 7-10 GPM as manufactured by Canplas Industries Ltd.

- 1. The unit shall be comprised of engineered thermoplastics to withstand operational temperatures up to 220°F (104°C) comprising a pedestrian rated cover capable of supporting 440 lb (200 kg) and incorporating an operationally air tight seal. The cover shall also utilize a quick access latching system to functionally retain and secure the cover to the tank, but allow consistent removal and replacement of the cover without operational compromise. Functional elements such as baffles will be made of material that prevents corrosion or deterioration and shall be easily removable for the purposes of maintenance, providing unrestricted upstream and downstream drain access. The grease interceptor shall be certified to the current version of the PDI-G101, ASME A112.14.3 or CSA B481.1 and where locally applicable have UPC listing.
  - a. A flow control device with integrated air intake and tool-less access to the orifice in service shall be provided with the interceptor.
- 2. **Model 3907A02 - 7GPM/14 lb (Hub Connection)**  
**Model 3907A02T - 7GPM/14 lb (Threaded Connection)**  
**Model 3907A02S - 7GPM/14 lb (Spigot Connection)**
  - a. Connection size (mechanical): 2" (51 mm)
  - b. Flow Control Models:
    - Hub Connection: 33922107C
    - Threaded Connection: 33922107AT
    - Spigot Connection: 33922107AS
  - c. Flow Rate: 7GPM (0.44 L/Sec).
  - d. Min. Grease Capacity: 14 lb (6.35 kg).
  - e. Average Efficiency % (ASME 112.14.3): 95.5%.
  - f. Actual Grease Capacity: 31.95 lb (14.49 kg).
  - g. Unit Weight (Empty): 13.8 lb (6.26 kg).
  - h. Liquid Capacity: 12.96 gal (49.06 L).
- 3. **Model 3910A02 - 10GPM/20 lb (Hub Connection)**  
**Model 3910A02T - 10GPM/20 lb (Threaded Connection)**  
**Model 3910A02S - 10GPM/20 lb (Spigot Connection)**
  - a. Connection size (mechanical): 2" (51 mm).
  - b. Flow Control Models:
    - Hub Connection: 3922110C
    - Threaded Connection: 3922110AT
    - Spigot Connection: 3922110AS
  - c. Flow Rate: 10GPM (0.63 L/Sec).
  - d. Min. Grease Capacity: 20 lb (9.07 kg).

- e. Average Efficiency % (ASME 112.14.3): 92.5%.
- f. Actual Grease Capacity: 38.07 lb (17.28 kg).
- g. Unit Weight (Empty): 13.8 lb (6.26 kg).
- h. Liquid Capacity: 12.96 gal (49.06 L).

**4. Model 3915A02C - 15GPM/30 lb (Hub Connection)  
Model 3915A02T - 15GPM/30 lb (Threaded Connection)  
Model 3915A02S - 15GPM/30 lb (Spigot Connection)**

- a. Connection size (mechanical): 2" (51 mm).
- b. Flow Control Models:
  - Hub Connection: 3922115C
  - Threaded Connection: 3922115AT
  - Spigot Connection: 3922115AS
- c. Flow Rate: 15GPM (0.94 L/Sec).
- d. Min. Grease Capacity: 30 lb (13.6 kg).
- e. Average Efficiency % (ASME 112.14.3): 92%.
- f. Actual Grease Capacity: 40.97 lb (18.58 kg).
- g. Unit Weight (Empty): 13.8 lb (6.26 kg).
- h. Liquid Capacity: 12.96 gal (49.06 L).

**B. Product: Grease Interceptor 20GPM as manufactured by Canplas Industries Ltd.**

- 1. The unit shall be comprised of engineered thermoplastics to withstand operational temperatures up to 220°F (104°C) comprising a pedestrian rated cover capable of supporting 440 lb (200 kg) and incorporating an operationally air tight seal. The cover shall also utilize a quick access latching system to functionally secure and retain the cover to the tank, but allow consistent removal and replacement of the cover without operational compromise. Functional elements such as baffles will be made of material that prevents corrosion or deterioration and shall be easily removable for the purposes of maintenance, providing unrestricted upstream and downstream drain access. The grease interceptor shall be certified to the current version of the PDI-G101, ASME A112.14.3 or CSA B481.1 and where locally applicable have UPC listing.
- a. A flow control device with integrated air intake and tool-less access to the orifice in service shall be provided with the interceptor.

**2. Model 3920A02 - 20GPM/40 lb (Hub Connection)  
Model 3920A02T - 20GPM/40 lb (Threaded Connection)  
Model 3920A02S - 20GPM/40 lb (Spigot Connection)**

- a. Connection size (mechanical): 2" (51 mm).
- b. Flow Control Models:
  - Hub Connection: 3922120C
  - Threaded Connection: 3922120AT
  - Spigot Connection: 3922120AS
- c. Flow Rate: 20GPM (1.26 L/Sec).
- d. Min. Grease Capacity: 40 lb (18.1 kg).
- e. Average Efficiency % (ASME 112.14.3): 95.4%.
- f. Actual Grease Capacity: 76.4 lb (34.65 kg).
- g. Unit Weight (Empty): 23 lb (10.4 kg).
- h. Liquid Capacity: 21.6 gal (81.8 L).

**C. Product: Grease Interceptor 25-35GPM as manufactured by Canplas Industries Ltd.**

- 1. The unit shall be comprised of engineered thermoplastics to withstand operational temperatures up to 220°F (104°C) comprising a pedestrian rated cover capable of supporting 440 lb (200 kg) and incorporating an operationally air tight seal. The cover shall also utilize a quick access latching system to functionally secure and retain the cover to the tank, but allow consistent removal

and replacement of the cover without operational compromise. Functional elements such as baffles will be made of material that prevents corrosion or deterioration and shall be easily removable for the purposes of maintenance, providing unrestricted upstream and downstream drain access. The grease interceptor shall be certified to the current version of the PDI-G101, ASME A112.14.3 or CSA B481.1 and where locally applicable have UPC listing.

- a. A flow control device with integrated air intake and tool-less access to the orifice in service shall be provided with the interceptor.
- 2. Model 3925ALT02 - 25GPM/50 lb (Hub Connection)  
Model 3925ALT02T - 25GPM/50 lb (Threaded Connection)  
Model 3925ALT02S - 25GPM/50 lb (Spigot Connection)**

- a. Connection size (mechanical): 2" (51 mm).
- b. Flow Control Models:
  - Hub Connection: 3922125C
  - Threaded Connection: 3922125AT
  - Spigot Connection: 3922125AS
- c. Flow Rate: 25GPM (1.6 L/Sec).
- d. Min. Grease Capacity: 50 lb (22.68 kg).
- e. Average Efficiency % (ASME 112.14.3): 98%.
- f. Actual Grease Capacity: 56.25 lb (25.51 kg).
- g. Unit Weight (Empty): 45 lb (20.4 kg).
- h. Liquid Capacity: 39.4 gal (149.1 L).

**3. Model 3925ALT03 - 25GPM/50 lb (Hub Connection)  
Model 3925ALT03T - 25GPM/50 lb (Threaded Connection)  
Model 3925ALT03S - 25GPM/50 lb (Spigot Connection)**

- a. Connection size (mechanical): 3" (76 mm).
- b. Flow Control Models:
  - Hub Connection: 3933125C
  - Threaded Connection: 3933125AT
  - Spigot Connection: 3933125AS
- c. Flow Rate: 25GPM (1.6 L/Sec).
- d. Min. Grease Capacity: 50 lb (22.68 kg).
- e. Average Efficiency % (ASME 112.14.3): 98%.
- f. Actual Grease Capacity: 56.25 lb (25.51 kg).
- g. Unit Weight (Empty): 45 lb (20.4 kg).
- h. Liquid Capacity: 39.4 gal (149.1 L).

**4. Model 3935A03 - 35GPM/70 lb (Hub Connection)  
Model 3935A03T - 35GPM/70 lb (Threaded Connection)  
Model 3935A03S - 35GPM/70 lb (Spigot Connection)**

- a. Connection size (mechanical): 3" (76 mm).
- b. Flow Control Models:
  - Hub Connection: 3933135C
  - Threaded Connection: 3933135AT
  - Spigot Connection: 3933135AS
- c. Flow Rate: 35GPM (2.2 L/Sec).
- d. Min. Grease Capacity: 70 lb (31.8 kg).
- e. Average Efficiency % (ASME 112.14.3): 98.6%.
- f. Actual Grease Capacity: 138.5 lb (62.8 kg).
- g. Unit Weight (Empty): 45 lb (20.4 kg).
- h. Liquid Capacity: 39.4 gal (149.1 L).

**5. Model 3935A04 - 35 GPM/70 lb (Hub Connection)  
Model 3935A04T - 35 GPM/70 lb (Threaded Connection)  
Model 3935A04S - 35 GPM/70 lb (Spigot Connection)**

- a. Connection size (mechanical): 4" (110 mm).
- b. Flow Control Models:
  - Hub Connection: 3944235C
  - Threaded Connection: 3944235AT
  - Spigot Connection: 3944235AS
- c. Flow Rate: 35GPM (2.2 L/Sec).
- d. Min. Grease Capacity: 70 lb (31.8 kg).
- e. Average Efficiency % (ASME 112.14.3): 98.6%.
- f. Actual Grease Capacity: 138.5 lb (62.8 kg).
- g. Unit Weight (Empty): 45 lb (20.4 kg).
- h. Liquid Capacity: 39.4 gal (149.1 L).



**D. Product: Endura Lo-Pro as manufactured by Canplas Industries Ltd.**

1. The interceptor shall be serviced with a minimum of 5" (127 mm) of overhead clearance. The unit shall be comprised of engineered thermoplastics to withstand operational temperatures up to 220 °F (104 °C) comprising a pedestrian rated cover capable of supporting 440 lb (200 kg) and incorporating an operationally air tight seal. The cover shall also utilize a quick access latching system to functionally retain and secure the cover to the tank, but allow consistent removal and replacement of the cover without operational compromise. Functional elements such as baffles will be made of material that prevents corrosion or deterioration and shall be easily removable for the purposes of maintenance, providing unrestricted upstream and downstream drain access. The grease interceptor shall be certified to the current version of the PDI-G101, ASME A112.14.3 or CSA B481.1 and where locally applicable have UPC listing.

**2. Model 3925A02LO - 25GPM/50 lb (Hub Connection)  
Model 3925A02LOT - 25GPM/50 lb (Threaded Connection)  
Model 3925A02LOS - 25GPM/50 lb (Spigot Connection)**

- a. Connection size (mechanical): 2" (51 mm)
- b. Flow Control Models:
  - Hub Connection: 3922125C
  - Threaded Connection: 3922125AT
  - Spigot Connection: 3922125AS
- c. Flow Rate: 25GPM (1.6 L/Sec).
- d. Min. Grease Capacity: 50 lb (22.68 kg).
- e. Average Efficiency % (ASME 112.14.3): 97.1%.
- f. Actual Grease Capacity: 53.4 lb (24.22 kg).
- g. Unit Weight (Empty): 23.9 lb (10.85 kg).
- g. Liquid Capacity: 18.9 gal (71.54 L).

**E. Product: Grease Interceptor 50GPM as manufactured by Canplas Industries Ltd.**

1. The unit shall be comprised of engineered thermoplastics to withstand operational temperatures up to 220°F (104°C) comprising a pedestrian rated cover capable of supporting 440 lb (200 kg) and incorporating an operationally air tight seal. The cover shall also utilize a quick access latching system to functionally secure and retain the cover to the tank, but allow consistent removal and replacement of the cover without operational compromise. Functional elements such as baffles will be made of material that prevents corrosion or deterioration and shall be easily removable for the purposes of maintenance, providing unrestricted upstream and downstream drain access. The grease interceptor shall be certified to the current version of the PDI-G101, ASME A112.14.3 or CSA B481.1 and where locally applicable have UPC listing.
  - a. A flow control device with integrated air intake and tool-less access to the orifice in service shall be provided with the interceptor.

**2. Model 3950A03 - 50GPM/100 lb (Hub Connection)  
Model 3950A03T - 50GPM/100 lb (Threaded Connection)  
Model 3950A03S - 50GPM/100 lb (Spigot Connection)**

- a. Connection size (mechanical): 3" (76 mm)
- b. Flow Control Models:
  - Hub Connection: 3933150
  - Threaded Connection: 3933150AT
  - Spigot Connection: 3933150AS

- c. Flow Rate: 50GPM (3.2 L/Sec).
- d. Min. Grease Capacity: 100 lb (45.4 kg).
- e. Average Efficiency % (ASME 112.14.3): 93.9%.
- f. Actual Grease Capacity: 122.07 lb (55.3 kg).
- g. Unit Weight (Empty): 60 lb (27.2 kg).
- h. Liquid Capacity: 52 gal (197 L).

**3. Model 3950A04 - 50GPM/100 lb (Hub Connection)  
Model 3950A04T - 50GPM/100 lb (Threaded Connection)**

- a. Connection size (mechanical): 4" (110 mm).
- b. Flow Control Models:
  - Hub Connection: 3944250
  - Threaded Connection: 3944250AT
- c. Flow Rate: 50 GPM (3.2 L/Sec).
- d. Min. Grease Capacity: 100 lb (45.4 kg).
- e. Average Efficiency % (ASME 112.14.3): 93.9%.
- f. Actual Grease Capacity: 122.07 lb (55.3 kg).
- g. Unit Weight (Empty): 60 lb (27.2 kg).
- h. Liquid Capacity: 52 gal (197 L).

**F. Product: Grease Interceptor (Extended Capacity) 75GPM as manufactured by Canplas Industries Ltd.**

1. The unit shall be comprised of engineered thermoplastics to withstand operational temperatures up to 160°F (71°C) comprising of two load rated covers capable of supporting min. 20,000 lb (9072 kg) and incorporating an operationally air tight seal. The covers shall utilize 4 bolts to functionally secure and retain the covers to the tank, but allow consistent removal and replacement of the cover without operational compromise. Functional elements such as baffles will be made of material that prevents corrosion or deterioration and shall be removable for the purposes of replacement, providing unrestricted upstream and downstream drain access. The grease interceptor shall be certified to the current version of the PDI-G101, ASME A112.14.3 or CSA B481.1 and where locally applicable have UPC listing.
  - a. A flow control device with integrated air intake and tool-less access to the orifice in service shall be provided with the interceptor.

**2. Model 4075A04 - 75 GPM/150 lb (Hub Connection)  
Model 4075A04T - 75 GPM/150 lb (Threaded Connection)**

- a. Connection size (mechanical): 4" (Sch40DWV) (110mm).
- b. Flow Control Model:
  - Hub Connection: 4044275
  - Threaded Connection: 4044275AT
- c. Flow Rate: 75GPM (4.74 L/Sec).
- d. Min. Grease Capacity: 150 lb (68.2 kg).
- e. Average Efficiency % (ASME 112.14.3): 98%.
- f. Actual Grease Capacity: 559 lb (253 kg).
- g. Unit Weight (Empty): 233 lb (106 kg).
- h. Liquid Capacity: 158 gallons (598 L).
- i. Cover Design Load (Traffic Rated): Exceeds 16,000 lb (7257 kg) (AASHTO 304-H20)
- j. Cover Load Capacity (Traffic Rated): CSA 'S' Rating, Special Duty: Exceeds 20,000 lb (9072 kg), -20°F to +100°F (-29°C to +38°C)
- k. Flow Control Device: Internal flow control device with air intake and access to the orifice in service shall be supplied with the interceptor.
- l. External Flow Control Device (optional For PDI Installations as required):
  - Optional External flow control device
  - PN: 4044275AS (Hub Connection) or
  - PN: 4044275AT (Threaded Connection) with integrated air intake and tool-less access to the orifice in service shall be supplied with the interceptor.
- m. Extension Risers: For use below grade; sized to project requirements on site. Provide with 1" markers/ribs

on riser, flanged bottom to interlock and secure to frame. Handle and outlet extensions, seals and fasteners to be supplied by manufacturer.

**G. Product: Grease Interceptor (Extended Capacity) 100 GPM as manufactured by Canplas Industries Ltd.**

1. The unit shall be comprised of engineered thermoplastics to withstand operational temperatures up to 160°F (71°C) comprising of two load rated covers capable of supporting min. 20,000 lb (9072 kg) and incorporating an operationally air tight seal. The covers shall utilize 4 bolts to functionally secure and retain the covers to the tank, but allow consistent removal and replacement of the cover without operational compromise. Functional elements such as baffles will be made of material that prevents corrosion or deterioration and shall be removable for the purposes of replacement, providing unrestricted upstream and downstream drain access. The grease interceptor shall be certified to the current version of the PDI-G101, ASME A112.14.3 or CSA B481.1 and where locally applicable have UPC listing.
2. **Model 40100A04 - 100GPM/200 lb (Hub Connection) Model 40100A04T- 100GPM/200 lb (Threaded Connection)**
  - a. Connection size (mechanical): 4" (Sch40DWV) (110mm).
  - b. Flow Control Model:
    - Hub Connection: 40442100
    - Threaded Connection: 40442100AT
  - c. Flow Rate: 100GPM (6.3 L/Sec).
  - d. Min. Grease Capacity: 200 lb (90.8 kg).
  - e. Average Efficiency % (ASME 112.14.3): 99%.
  - f. Actual Grease Capacity: 1058 lb (479.9 kg).
  - g. Unit Weight (Empty): 283 lb (128.3 kg).
  - h. Liquid Capacity: 257 gallons (972 L).
  - i. Cover Design Load (Traffic Rated): Exceeds 16,000 lb (7257 kg) (AASHTO 304-H20)
  - j. Cover Load Capacity (Traffic Rated): CSA 'S' Rating, Special Duty: Exceeds 20,000 lb (9072 kg), -20°F to +100°F (-29°C to +38°C)
  - k. Internal Flow Control Device: Internal flow control device with integrated air intake and tool-less access to the orifice in service shall be provided with the interceptor.
  - l. External Flow Control Device (optional For PDI Installations as required): External flow control device  
PN: 40442100AS (Hub Connection) or  
PN: 40442100AT (Threaded Connection) with air intake and access to the orifice in service shall be supplied with the interceptor.
  - m. Extension Risers: For use below grade; sized to project requirements on site. Provide with 1" markers/ribs on riser, flanged bottom to interlock and secure to frame. Handle and outlet extensions, seals and fasteners to be supplied by manufacturer.

**2.4 SOLIDS INTERCEPTOR**

**A. Product: Solids Interceptor as manufactured by Canplas Industries Ltd.**

1. Parts in direct contact with flow shall be constructed of engineered thermoplastic capable of withstanding operational temperatures of 220°F (104°C). Baffles shall be perforated with slots as opposed circular perforations for enhanced straining of elongated debris e.g. mop strings, spaghetti etc. The solids interceptor shall be removable for cleaning and in operation have a minimum flow rate greater than 50GPM (3.2 L/Sec) when loaded to 50%

of its solids-holding capacity. Any baffles/straining method used shall also be removable for maintenance and operation shall use a dual means of filtration on solid material within the flow. When installed in a stand-alone configuration the tank will meet the same specification as above and have both a lid which is airtight and capable of supporting 440 lb (220 kg).

2. Type: Stand Alone Model 3911A02: Solids Interceptor. Complete with Solids Basket Accessory (SBA): 2" (51 mm) inlet.
3. Type: Integral to Interceptor Model 3911A-1: Solids Basket Accessory (SBA).

**PART 3 EXECUTION**

**3.1 EXAMINATION**

- A. Do not begin installation until substrates have been properly prepared.
- B. If substrate preparation is the responsibility of another installer, notify Architect of unsatisfactory preparation before proceeding.

**3.2 PREPARATION**

- A. Clean surfaces thoroughly prior to installation.
- B. Prepare surfaces using the methods recommended by the manufacturer for achieving the best result for the substrate under the project conditions.

**3.3 INSTALLATION**

- A. Install in accordance with manufacturer's instructions.
- B. Do not pressurize any interceptor as there is a serious risk of injury and death. The interceptor as an appurtenance shall be isolated for the purposes of leak testing the upstream and downstream drainage system when commissioning and verifying the system operation.
- C. Interceptor tank will be installed to the associated drainage system using mechanical joint couplings approved by the Authority Having Jurisdiction (AHJ). Supplied by others.
- D. When installing in-floor, tanks will be filled to static water level with water to prevent movement and resist pressure of backfilling process.
- E. Cover will be secured in place during backfilling process to maintain structural rigidity and form and to prevent ingress of foreign bodies into both the interceptor and drainage system.

**3.4 FIELD QUALITY CONTROL**

- A. Provide inspection certificates of Authority Having Jurisdiction (AHJ).

**3.5 PROTECTION**

- A. Protect installed products until completion of project.
- B. Touch-up, repair or replace damaged products before Substantial Completion.

**END OF SECTION**







# canplas<sup>®</sup>

*Molding a better future*



The Canplas manufacturing location in Barrie, Ontario, Canada is ISO 9001 and 14001 registered facility. Our quality management system has been registered for the design, manufacture and distribution of high quality injection molded products used in plumbing, industrial, ventilation and central vacuum applications.



[www.arcat.com](http://www.arcat.com)



[www.csc-dcc.ca](http://www.csc-dcc.ca)



[www.csinet.org](http://www.csinet.org)

**Canplas Industries Ltd.**  
P.O. Box 1800, 500 Veterans Dr.  
Barrie, ON, Canada L4M 4V3  
Tel: (705) 726-3361  
Toll Free: 1-800-461-5300  
Fax: (705) 726-2186  
Toll Free Fax: 1-888-432-2201

**Canplas LLC**  
11402 East 53rd Ave.  
Suite 200, Denver, CO, USA 80239  
Tel: (303) 373-1918  
Toll Free: 1-888-461-5307  
Fax: (303) 373-1923  
Toll Free Fax: 1-888-461-5309

[www.endurainterceptor.com](http://www.endurainterceptor.com)