

FEATURES

- Black steel body with insulated door
- Stainless steel interior & work top
- Fan forced cooling system
- Lockable door
- Includes 1 heavy duty epoxy coated shelf
- Interior LED lighting
- Rear mounted compressor & condensing unit
- Self-evaporation water tray
- Removable installation board for easy cleaning & service
- Includes adjustable feet and 3" casters
- Dixell digital temperature controller
- Heavy duty 1/6 HP Embraco compressor

TEMPERATURE

- Interior temperature range: 0°C to 8°C (32°F to 46°F)

WARRANTY

- 2 years parts and labour
7 years compressor warranty
- Extended warranty options available



BBG-30-24



BBS-30-24

Model BBG-30-24/ BBS-30-24

Back Bar Cooler

Project: _____

Date: _____

Price: _____

SPECIFICATIONS

Volts (V)	Watts (W)	Amps (A)	Volume (cu./ft)	Refrigerant	Overall Dimensions			Interior Dimensions			Weight	
					Width	Depth	Height	Width	Depth	Height	Net	Gross
115V	218W	1.9A	6.5	R290	23.5	30.5	39	N/A	N/A	N/A	200 LBS	N/A

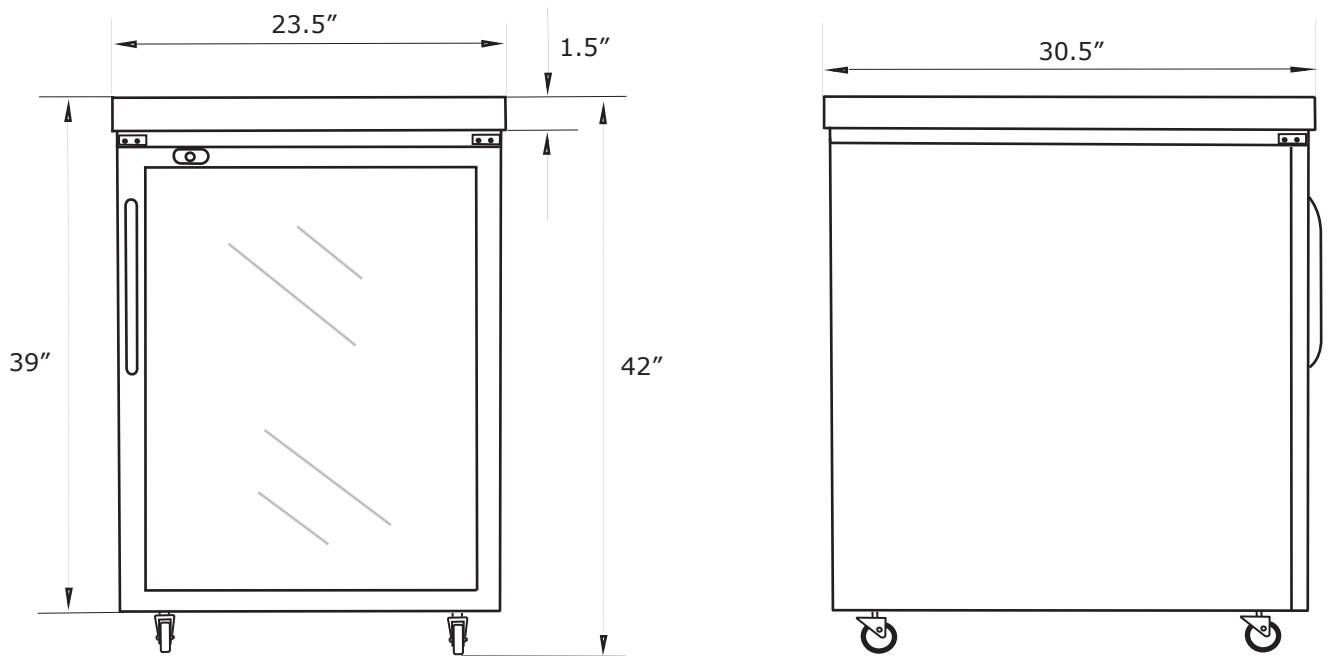

CERTIFICATIONS:

