

FEATURES

- Black steel body with insulated doors
- Stainless steel interior & work top
- Fan forced cooling system
- Interior LED lighting
- Lockable doors
- Self-evaporation water tray
- Includes 4 heavy duty epoxy coated shelves (2 per door)
- Side mounted compressor & condensing unit
- Includes adjustable feet and 3" casters
- Removable installation board for easy cleaning & service
- Dixell digital temperature controller
- Heavy duty 1/5 HP Embraco compressor

TEMPERATURE

- Interior temperature range: 0°C to 8°C (32°F to 46°F)



BBG-28-69



BBS-28-69

WARRANTY

- 2 years parts and labour
7 years compressor warranty
- Extended warranty options available

Project: _____

Date: _____

Price: _____

Model BBG-28-69/ BBS-28-69

Back Bar Cooler

SPECIFICATIONS

Volts (V)	Watts (W)	Amps (A)	Volume (cu./ft)	Refrigerant	Overall Dimensions			Interior Dimensions			Weight	
					Width	Depth	Height	Width	Depth	Height	Net	Gross
115V	414W	3.6A	23.3	R290	69	28	35.5	N/A	N/A	N/A	395 LB	N/A

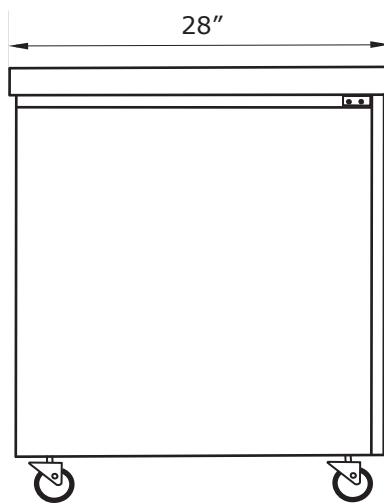
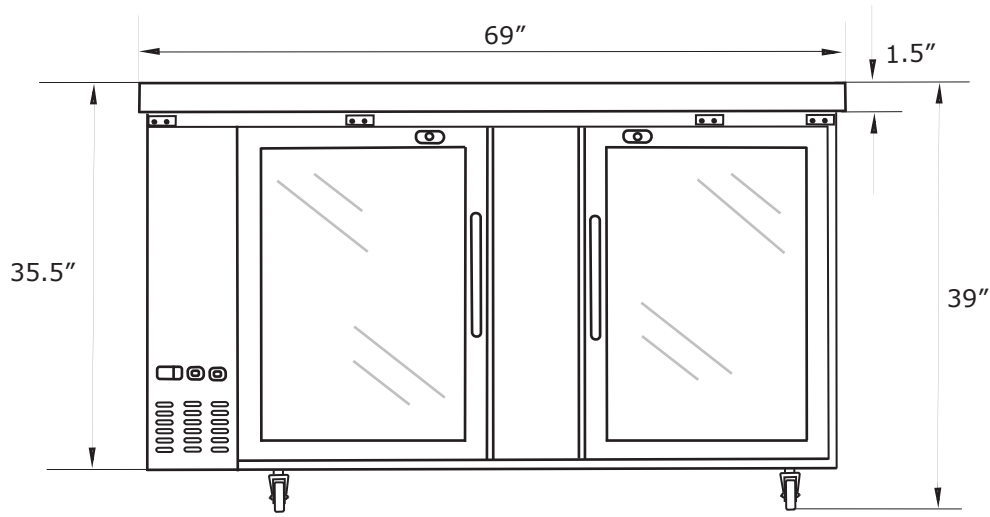

Back Bar Cooler

Model BBG-28-69/BBS-28-69

CERTIFICATIONS:



NEMA 5-15P

Local: 905-669-8003
Toll Free: 1-833-669-8003

2884 Slough Street, Unit 1
Mississauga, ON Canada