

# ALPHA

FOOD EQUIPMENT

## ALPHA 50 QT TEN SPEED SPIRAL MIXER

AVS-50

Project: \_\_\_\_\_ Date: \_\_\_\_\_ Price: \_\_\_\_\_

### KEY FEATURES:

- Heavy Duty Painted Steel Body
- 304 Stainless Bowl, Hook & Wire Cage
- Variable Frequency, Belt Driven Motor
- Inverter Technology For Quick Speed Changes
- 10 Mixing Speeds
- Reverse & Inching Function For Easy Removal
- ETL & NSF Certified



Introducing the brand new Alpha spiral mixer.

The unique variable frequency motor has many benefits, including quieter operation, more mixing speeds, more torque, and easier maintenance.

The digital controller interface makes operation easy, and includes a reverse and inching feature to help with dough removal and cleaning.

Suitable for a wide variety of doughs, with low and high hydration levels. The digital timer allows you to set the mixer and walk away while you work on other tasks.



### CERTIFICATIONS:



Specifications are subject to change without notice

2884 Slough Street, Unit 1, Mississauga, ON Canada L4T1G3

Toll Free: 1-833-669-8003

© Alpha Food Equipment

ALPHA

AVS-50

50 QT SPIRAL MIXER

# SPECIFICATIONS:

## CONSTRUCTION:

- 304 stainless steel bowl & cage for durability and longevity
- Heavy duty painted steel body
- Includes casters for mobility and stabilizing feet

## CONTROLS:

- 10 mixing speeds to accommodate a wide range of doughs
- Reverse and inching function improves dough consistency, and eases the dough removing and cleaning process
- Simple, easy to use control panel means there is no learning curve, just get right into baking

## CAPACITY:

- Max Mixing Capacity: 25 KG/55 LBS (Flour); 40 KG/88 LBS (Dough)
- Total Bowl Capacity: 55 L

## ELECTRICAL:

- 208V, 2500W, 12A; 3 HP Motor
- Includes cord and plug



NEMA 6-50P

## WARRANTY:

- 2 Years Parts And Labour Warranty

## SAFETY:

- Emergency stop and safety cage prevents injury while in operation, and ensures that you can quickly stop the machine if needed

## MOTOR:

- Variable frequency motor removes the need for extra gears, reducing noise while increasing the torque capabilities
- Belt driven to reduce noise while in operation, making repairs quick and easy
- Inverter technology adjusts the motor power to keep the speed more consistent, even with changing loads

## SPEEDS:

- 10 Variable Mixing Speeds
- Hook Speed Range: 130 to 230 RPM
- Bowl Speed Range: 13 to 23 RPM

UNIT MEASUREMENTS:
Width: 24 5/8" (625 mm)
Depth: 40 1/4" (1020 mm)
Height: 41 3/4" (1060 mm)
Net Weight: 440 Lbs (200 Kg)

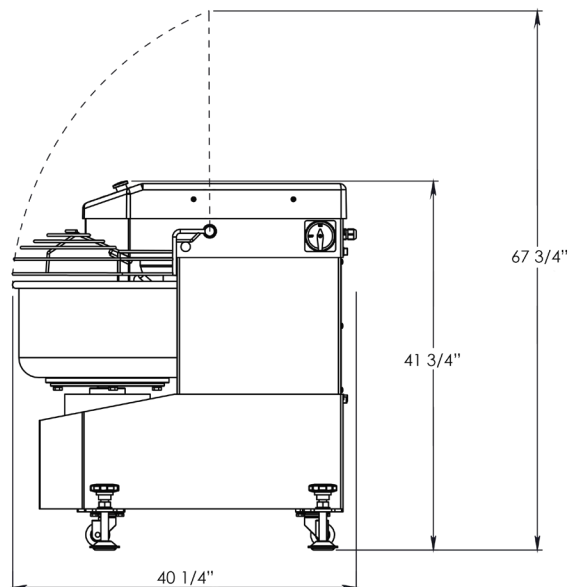
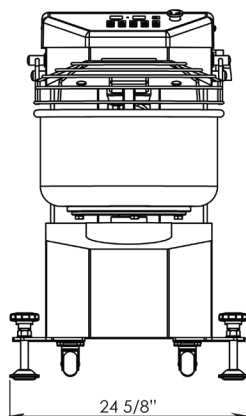
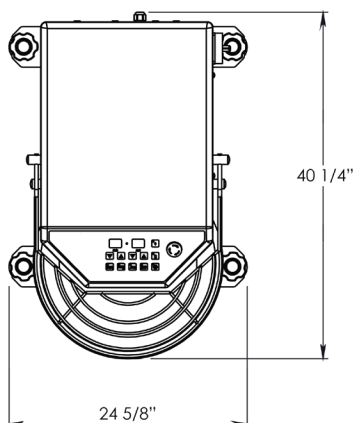

Specifications are subject to change without notice