

ALPHA

FOOD EQUIPMENT

ALPHA 10 QT TEN SPEED SPIRAL MIXER

AVS-10

ALPHA

Project: _____ Date: _____ Price: _____

KEY FEATURES:

- Heavy Duty Painted Steel Body
- 304 Stainless Bowl, Hook & Wire Cage
- Variable Frequency, Belt Driven Motor
- Inverter Technology For Quick Speed Changes
- 10 Mixing Speeds
- Reverse Bowl Function For Easy Removal
- ETL & NSF Certified



Introducing the brand new Alpha spiral mixer.

The unique variable frequency motor has many benefits, including quieter operation, more mixing speeds, more torque, and easier maintenance.

The digital controller interface makes operation easy, and includes a reverse feature to help with dough removal and cleaning.

Suitable for a wide variety of doughs, with low and high hydration levels. The digital timer allows you to set the mixer and walk away while you work on other tasks.



AVS-10
10 QT SPIRAL MIXER

CERTIFICATIONS:



Specifications are subject to change without notice

SPECIFICATIONS:

CONSTRUCTION:

- 304 stainless steel bowl & cage for durability and longevity
- Heavy duty painted steel body

CONTROLS:

- 10 mixing speeds to accomodate a wide range of doughs
- Reverse function improves dough consistency, and eases the dough removing and cleaning process
- Simple, easy to use control panel means there is no learning curve, just get right into baking

CAPACITY:

- Max Mixing Capacity: 3.5 KG/7.7 LBS (Flour); 5.6 KG/12.3 LBS (Dough)
- Total Bowl Capacity: 10 L

ELECTRICAL:

- 120V, 750W, 6.25A; 1 HP Motor
- Includes cord and plug



NEMA 5-15P

WARRANTY:

- 2 Years Parts And Labour Warranty

SAFETY:

- Emergency stop and safety cage prevents injury while in operation, and ensures that you can quickly stop the machine if needed

MOTOR:

- Variable frequency motor removes the need for extra gears, reducing noise while increasing the torque capabilities
- Belt driven to reduce noise while in operation, making repairs quick and easy
- Inverter technology adjusts the motor power to keep the speed more constant, even with changing loads

SPEEDS:

- 10 Variable Mixing Speeds
- Hook Speed Range: 108 to 272 RPM
- Bowl Speed Range: 11 to 27 RPM

UNIT MEASUREMENTS:

Width: 12 3/4" (323 mm)

Depth: 21 5/8" (550 mm)

Height: 17" (433 mm)

Net Weight: 73 Lbs (33 Kg)

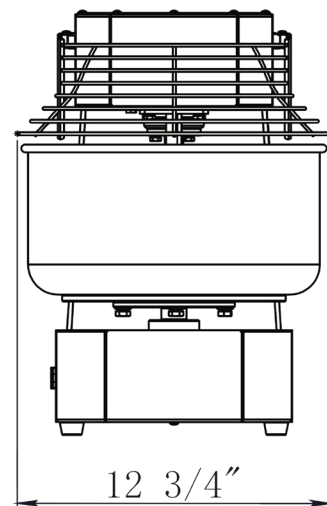
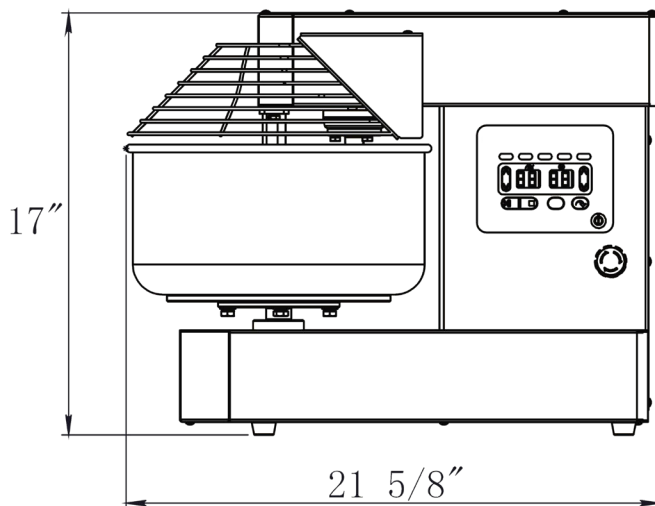

Specifications are subject to change without notice

2884 Slough Street, Unit 1, Mississauga, ON Canada L4T1G3 Toll Free: 1-833-669-8003

© Alpha Food Equipment

10 QT SPIRAL MIXER

AVS-10

ALPHA