

LapAR™

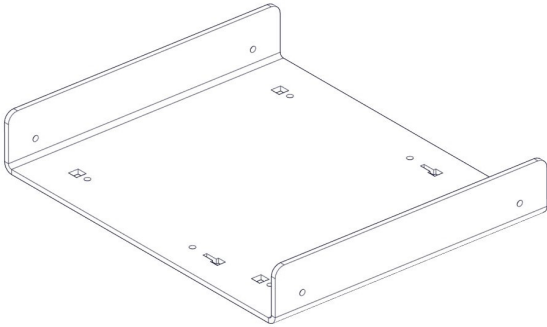

Inovus
Medical®

a c c e s s i b l e a f f o r d a b l e f u n c t i o n a l



- 1 | When opening your simulator it is recommended that you unpack all package contents and arrange them before starting construction. Once you have done this, take the first part labelled AR20_BTM01 and lay it on a secure flat surface.

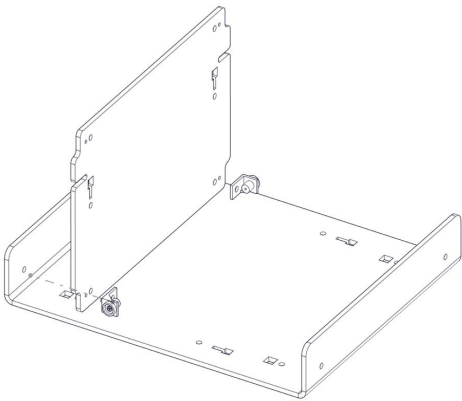

- 2 | Now take the following parts 2x MA01, AR20_U02, 2x WN14 & 2x M5B24. Using the image as a guide, pay close attention to the part orientation in this step or you will have to undo work at a later stage.

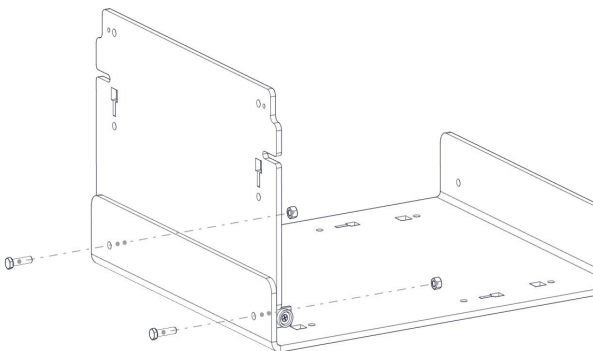

- 3 | Screw into place 2x MA01 using 2x M5B24 and 2x WN14

(Use the pin on part MA01 to find the correct position)

- 4 | Repeat the last two steps with the same parts on the front panel AR20_U01 as shown in the image.

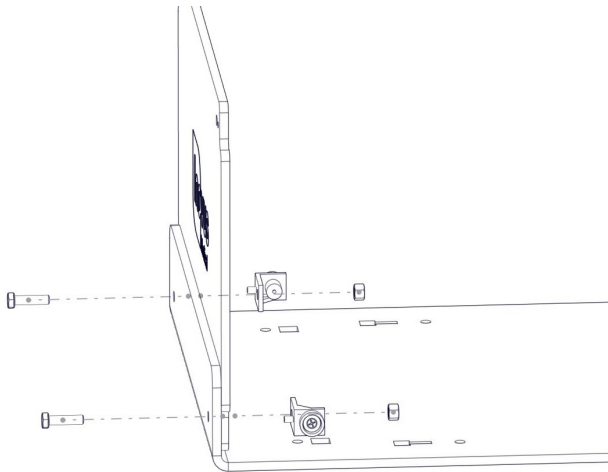

- 5 | Take 4x AR20_M-BKT, position them in the keys provided. In a practical sense this will need to be done one at a time with the simulator positioned on its side.

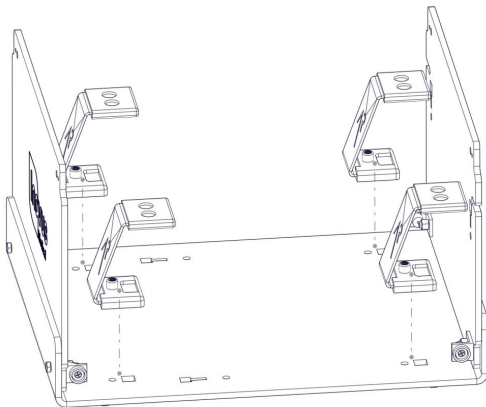

- 6 | Using 4x M5B24 screw each AR20_M-BKT into position on the base. These parts are threaded for ease of assembly.

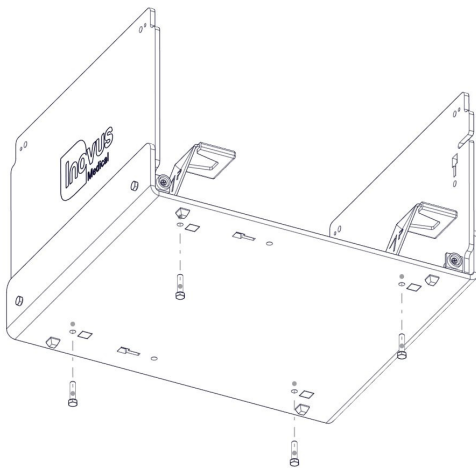

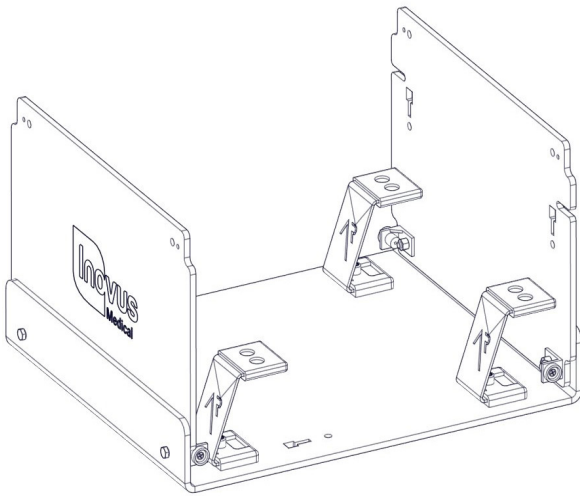

- 7 | At this stage the simulator should look exactly like the reference image. If something appears to be incorrect, go back through the steps again.

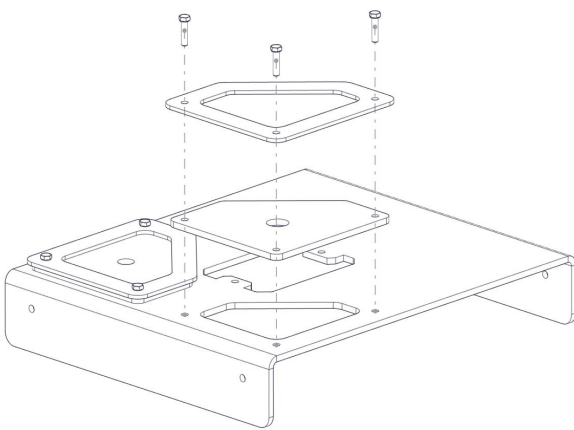

- 8 | Locate the following parts 1x AR20_TPBO1, 2x AR20_BKT, 2x AR20_SK, 6x M5B24 & 6x WN14 to begin the top bracket sub-assembly. Placing the AR20_SK on to the top surface of the AR20_TPBO1 ensure that the holes align correctly. You can now position the black AR20_BKT on top of the silicone skin, pushing three M5B24 through the holes. Now move to the next step.

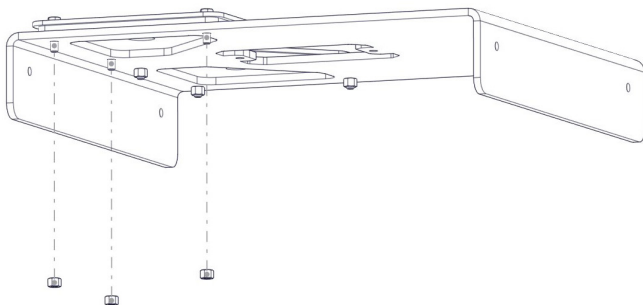

- 9 | Now attach 3x WN14 to the bolts coming through the bottom surface. Repeat this process on the opposite side to complete the assembly.

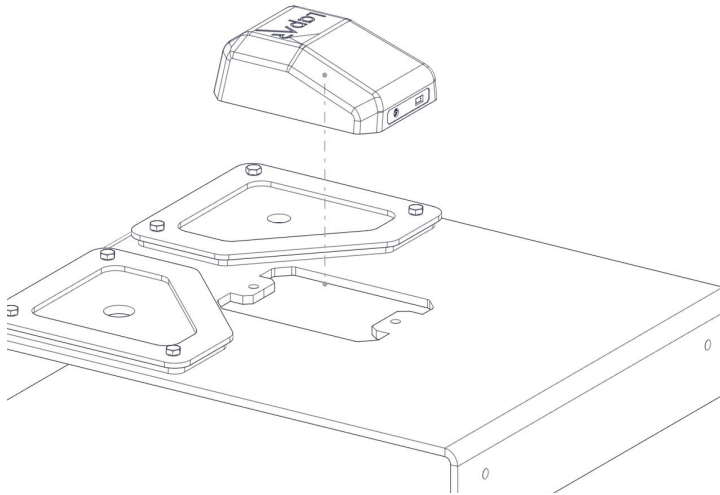

- 10 | Remove the AR20_CAM from its packaging and place into position as shown.

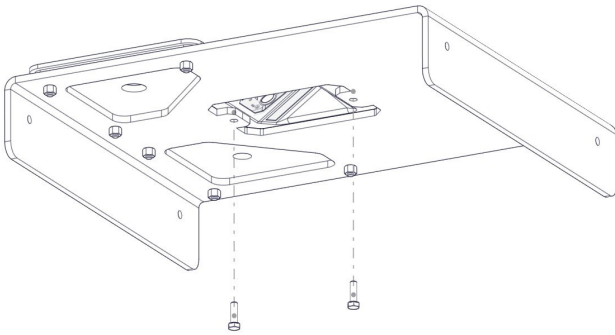

- 11 | Take 2x M5B24 bolts and affix the AR20_CAM into position. DO NOT plug-in at this stage.

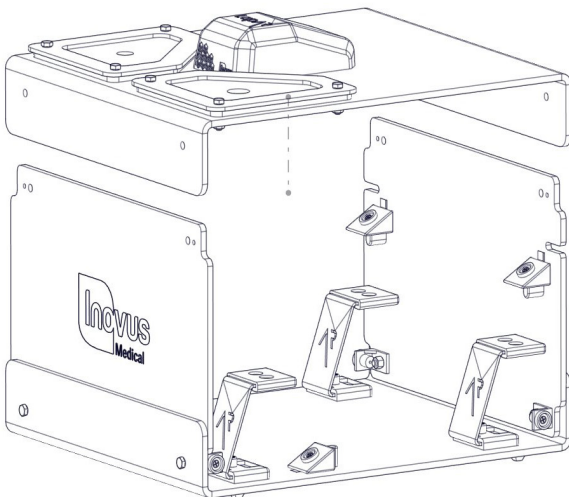

- 12 | Take the sub-assembly from the last four steps and place it over the upright panel of the simulator as shown.

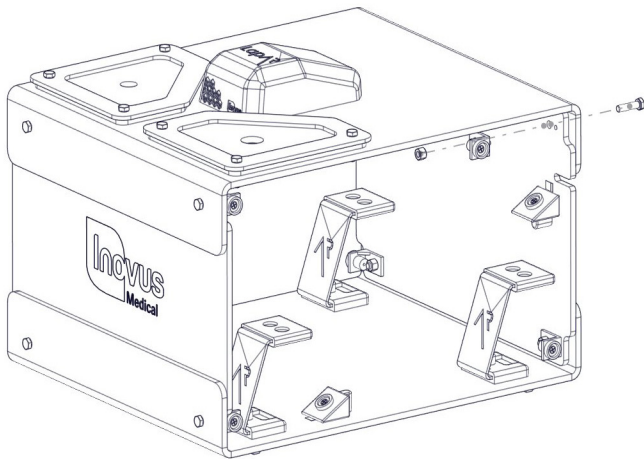

13 | Using 4x MA01, 4x WN14 & 4x M5B24, repeat the process from steps 2,3 & 4. Do this on each corner so that a magnet is in place for the side panels to connect into.

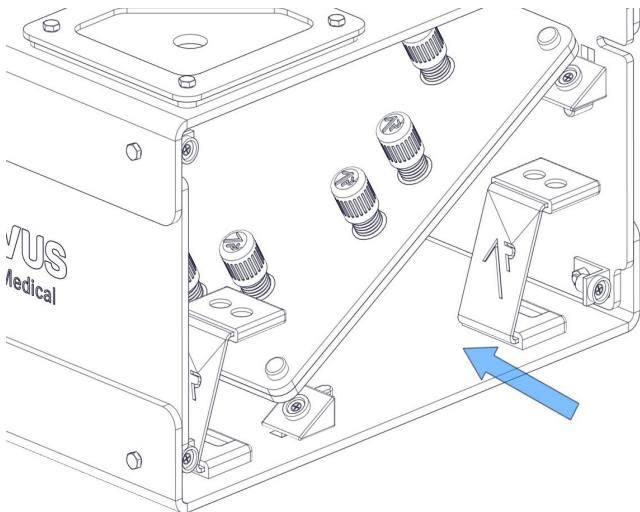

14 | It is important to note that the simulator is capable of multiple platform positions. When inserting AR20_TAB you will most commonly use the angled base for Augmented Reality applications.

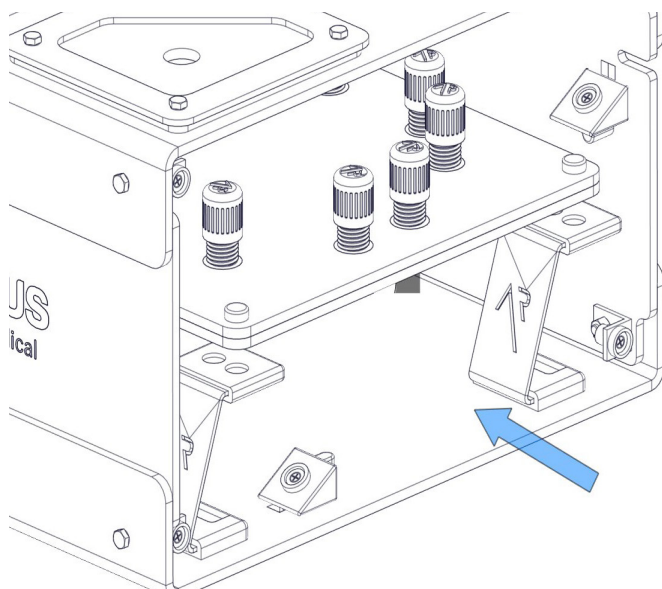

15 | You will use the flat platform for LapPass® and any other non-AR tasks. Enterprise users can use this for any tasks they like, including those where electro-surgical instruments are required.

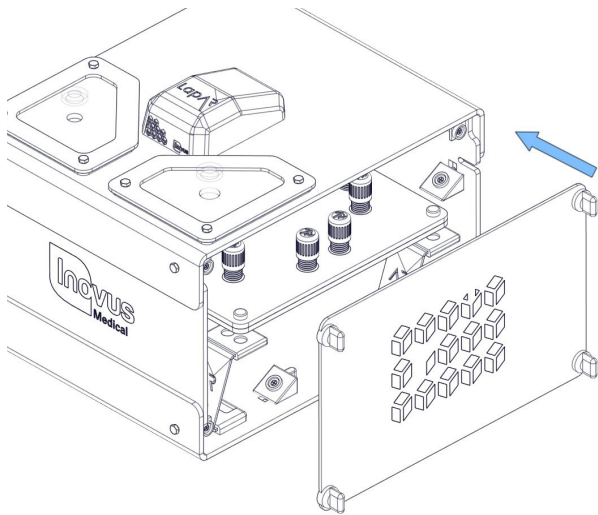

16 | Snap into place both side panels and move on.

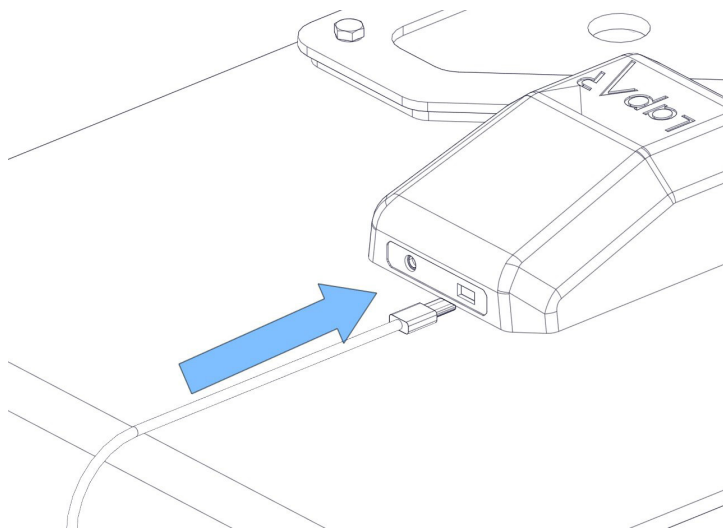

17 | Connect the USB micro into the back of the camera.

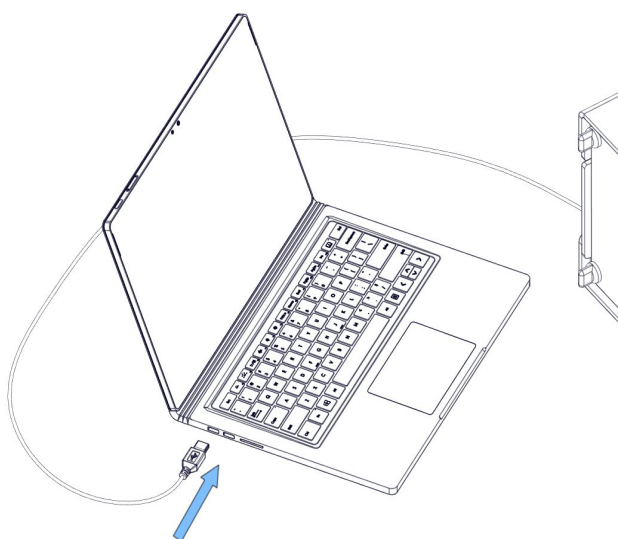

18 | Connect the other end of this cable into your Laptop or PC. You will have received a link from us shortly after purchase. Follow this to download the software platform required.

This email also contains user account information such as an activation code and a link to your online portfolio.

All other instructions are given inside the software.

Warranty

This limited warranty applies to any order, purchase, receipt, delivery or use of any products and services (collectively, in a "purchase") from Inovus Ltd® or any of its subsidiaries or affiliates or authorised reseller ("reseller"). If you enter into a separate written agreement with any of the aforementioned this warranty may be declared null and void.

This warranty applies to your purchase unless you notify Inovus Ltd® in writing that you do not agree to this agreement within 15 days after you receive this agreement and you return your product or cancel services under Inovus Ltd's refund policy. This agreement contains a dispute resolution clause (please see below).

THE TERMS AND CONDITIONS APPLICABLE TO INOVUS LIMITED® WARRANTY ARE AS SET FORTH BELOW:

Limited Warranty

Inovus Ltd® warrants to the end user ("Customer") that the product will be free from defects in workmanship and materials, under normal use and service, for one (1) year, or such longer period as Inovus Ltd® may announce publicly from time to time for particular products, from the date of purchase from Inovus Ltd® or an authorized reseller. Inovus Ltd®'s sole obligation under this express warranty shall be, at Inovus Ltd®'s option and expense, to repair the defective product or part, deliver to Customer an equivalent product or part to replace the defective item, or if neither of the two foregoing options is reasonably available, Inovus Ltd® may, in its sole discretion, refund to Customer the purchase price paid for the defective product. All products that are replaced will become the property of Inovus Ltd®.

Replacement products or parts may be new or reconditioned. Inovus Ltd® warrants any replaced or repaired product or part for ninety (90) days from shipment, or the remainder of the initial warranty period, whichever is longer. Products returned to Inovus Ltd® must be sent prepaid and packaged appropriately for safe shipment, and it is recommended that they be insured or sent by a method that provides for tracking of the package. Responsibility for loss or damage does not transfer to Inovus Ltd® until the returned item is received by Inovus Ltd®. The repaired or replaced item will be shipped to Customer, at Inovus Ltd®'s expense, no later than thirty (30) days after Inovus Ltd® receives the defective product, and Inovus Ltd® will retain risk of loss or damage until the item is delivered to Customer.

Exclusions

Inovus Ltd® will not be liable under this limited warranty if its testing and examination show that the alleged defect or malfunction in the product does not exist or results from:

- Failure to follow Inovus Ltd® installation, operation, or maintenance instructions
- Unauthorized product modification or alteration
- Unauthorized use of common carrier communication services accessed through the product
- Abuse, misuse, negligent acts or omissions of Customer and persons under Customer's control; or
- Acts of third parties, acts of God, accident, fire, lighting, power surges or outages, or other unpredictable random hazards.

WARRANTY EXCLUSIVE. IF AN INOVUS LTD® PRODUCT DOES NOT OPERATE AS WARRANTED ABOVE, CUSTOMER'S SOLE REMEDY FOR BREACH OF THAT WARRANTY SHALL BE REPAIR, REPLACEMENT, OR REFUND OF THE PURCHASE PRICE PAID, AT INOVUS LTD®'S OPTION. TO THE FULL EXTENT ALLOWED BY LAW, THE FOREGOING WARRANTIES AND REMEDIES ARE EXCLUSIVE AND ARE IN LIEU OF ALL OTHER WARRANTIES, TERMS, OR CONDITIONS, EXPRESS OR IMPLIED, EITHER IN FACT OR BY OPERATION OF LAW, STATUTORY OR OTHERWISE, INCLUDING WARRANTIES, TERMS, OR CONDITIONS OF , FITNESS FOR A PARTICULAR PURPOSE, SATISFACTORY QUALITY, CORRESPONDENCE WITH DESCRIPTION, AND NON-INFRINGEMENT, ALL OF WHICH ARE EXPRESSLY DISCLAIMED. INOVUS LTD® NEITHER ASSUMES NOR AUTHORIZES ANY OTHER PERSON TO ASSUME FOR IT ANY OTHER LIABILITY IN CONNECTION WITH THE SALE, INSTALLATION, MAINTENANCE OR USE OF ITS PRODUCTS.

Support and service agreements

If you purchased your product from an Inovus Ltd® Authorized Reseller, contact the Authorized Reseller for information about support and service agreements applicable to your product. For information on Inovus Ltd®'s service, go to the Inovus Ltd web site www.inovus.org, or contact Inovus Ltd® at support@inovus.org.

Limitation of Liability

TO THE FULL EXTENT ALLOWED BY LAW, INOVUS LTD® EXCLUDES FOR ITSELF AND ITS SUPPLIERS ANY LIABILITY, WHETHER BASED IN CONTRACT OR TORT (INCLUDING NEGLIGENCE), FOR INCIDENTAL, CONSEQUENTIAL, INDIRECT, SPECIAL, OR PUNITIVE DAMAGES OF ANY KIND, OR FOR LOSS OF REVENUE OR PROFITS, LOSS OF BUSINESS, LOSS OF INFORMATION OR DATA, OR OTHER FINANCIAL LOSS ARISING OUT OF OR IN CONNECTION WITH THE SALE, INSTALLATION, MAINTENANCE, USE, PERFORMANCE, FAILURE, OR INTERRUPTION OF ITS PRODUCTS, EVEN IF INOVUS LTD® OR ITS AUTHORIZED RESELLER HAS BEEN ADVISED OF THE POSSIBILITY OF SUCH DAMAGES, AND LIMITS ITS LIABILITY TO REPAIR, REPLACEMENT, OR REFUND OF THE PURCHASE PRICE PAID, AT INOVUS LTD®' OPTION.

THIS DISCLAIMER OF LIABILITY FOR DAMAGES WILL NOT BE AFFECTED IF ANY REMEDY PROVIDED HEREIN SHALL FAIL OF ITS ESSENTIAL PURPOSE.

Returns Policy

Thank you for purchasing from Inovus. If you are not entirely satisfied with your product then there are few ways we can help:

Returns

You have 14 calendar days to return an item from the date you received it. To be eligible for a return, your item must be unused and in the same condition that you received it. Your item must be returned in the original packaging and you must have the receipt or proof of purchase. Responsibility for the product will remain with you until it is received by Inovus®.

Refunds/Replacements

Once we receive your item, we will inspect it and notify you that we have received your returned item. We will immediately notify you on the status of your refund after inspecting the item. If your return is approved, we will initiate a refund to your credit card (or original method of payment) or dispatch a replacement item depending on your preference. If you opt for a full refund you will receive the credit within a certain amount of days, depending on your card issuer's policies.

Shipping

You will be responsible for paying for your own shipping costs for returning your item. Shipping costs are nonrefundable. If you receive a refund, the cost of return shipping will be deducted from your refund.

Contact Us

If you have any questions on how to return your item to us, contact us via email at support@inovus.org or telephone on (+44) 01744 752952.

Designed and manufactured by



E: info@inovus.org

T: +44 (0) 1744 752 952

W: www.inovus.org

