

# ARLSWP-22

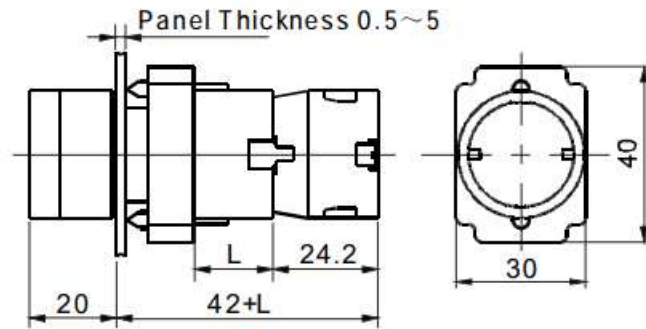
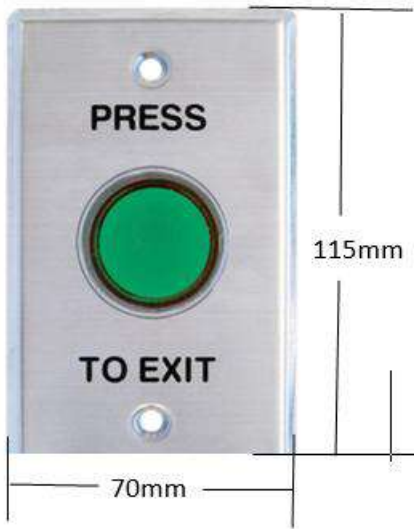

## Specifications

Operating Temperature	- 25°C~+55°C(no freezing)	
Operating Humidity	45 ~ 85%RH(no condensation)	
Operating Altitude	Installation site can't be over 2000m above sea level.	
Contact Material	- silver - silver alloy - gold-clad silver, cladding thickness is 3 μ m	
Contact Resistance	≤50m	
Insulation Resistance	≥100M	
Dielectric Strength	3000V, Alternating Current 50Hz	
Vibration Resistance	50Hz, Amplitude 1.0mm p-p	
Shock Resistance	≥10g	
Life	Mechanical	Momentary : ≥1,000,000 times; alternate, selector : ≥500,000 times; key-lock, emergency : ≥200,000 times
	Electrical	5万times ≥
Terminal	Screw terminal, connecting ability: Min : 1×0.5mm <sup>2</sup> , Max : 2×1.5mm <sup>2</sup> or 1×2.5mm <sup>2</sup> (with or without connecting link)	
Operation	Operation strength: 800gf~2200gf, according to the quantity of switch units Operation travel : About 5.5mm (For push button type)	
Pollution Degree	3 degrees	