



X32

FEATURES

- 2 piece aluminum construction
- Motorcycle industry standard (100mm x 30mm) caliper mount
- Multiple piston material options



SPECIFICATIONS

Weight	1,07 Kg
Lining Type	Sintered
Total Lining Area	2116 mm ²
Usable Lining Thickness Per Pad	4,39 mm
Piston Diameter	Twin Opposed 32 mm
Fluid Type	Brake Fluid
Fluid Inlet	3:00, 9:00
Bleeder	Banjo Bleeder
Rotor Diameter	152,4 mm – 355,6 mm

Specifications are guidelines only and subject to change. Consult Hayes Performance Systems for specific model, part number, and assembly drawings -contact@hbpsi.com.

REFERENCE DIMENSIONS

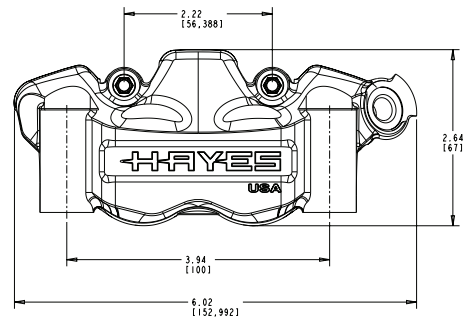

TORQUE INFORMATION

