



ADRENALINE

FEATURES

- Capable of 16347,21 N of clamp force
- Compact size ideal for mounting inside the wheel
- One piece cast aluminum housing
- Square seal piston retraction for constant running clearance
- Floating housing design for mounting ease
- Long-lasting brake pads



SPECIFICATIONS

Weight	1,27 Kg
Rotor Thickness	3,96 mm - 6,35 mm
Lining Type	Sintered, Non-Asbestos Organic, Semi-Metallic
Piston Diameter	Twin Piston 31,75 mm
Max Pressure	103,42 bar
Fluid Type	Brake Fluid
Fluid Inlet	Center
Bleeder	3:00, 9:00

Specifications are guidelines only and subject to change. Consult Hayes Performance Systems for specific model, part number, and assembly drawings -contact@hbpsi.com.

REFERENCE DIMENSIONS

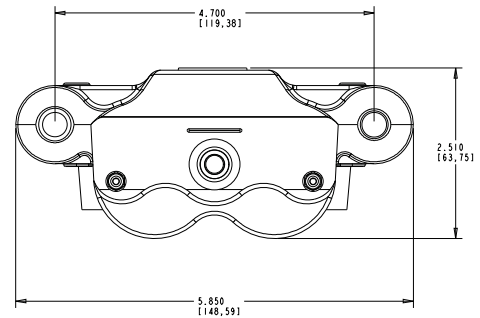

TORQUE INFORMATION

