

GENEVERSE

HOMEPower TWO PRO

Backup Battery Power Station

2419WH / 2200W-4400W

USER GUIDE

In the Box

1

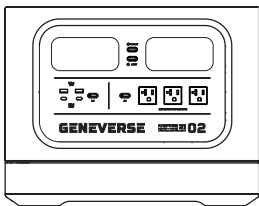

HOMEPower TWO PRO
Backup Battery Power Station

Download the Geneverse Mobile App



2

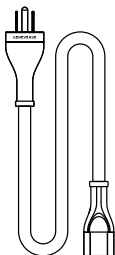

AC Charging Cable

3

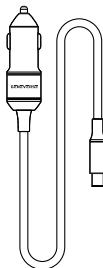

Car Charging Cable

4

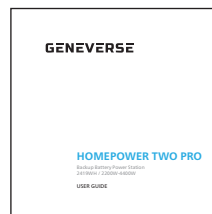

User Guide

How It Works

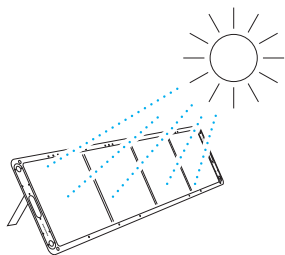

AC OUTLET



SOLAR POWER



CAR OUTLET

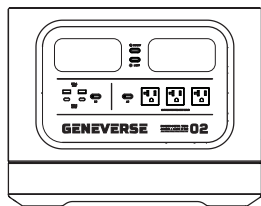

HOME APPLIANCES



COMMUNICATION DEVICES



LIGHTING



MEDICAL DEVICES



HOME OFFICE



TOOLS

1

Charge or Harness the Sun's Energy

Charge the backup battery power station from a solar panel, AC outlet, or carport.

2

Store Power for Up to One Year

When fully charged, store power in the HOMEPOWER TWO PRO for up to one year of emergency backup power.

3

Power Your Home Appliances

Power your devices from the stored energy by connecting them to your power station.

3 Ways to Recharge

1

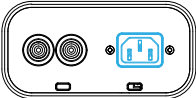

By AC / Wall Outlet or Gas Generator
(1500W of input): 1.5 hours to 80%,
2 hours to 100%



1.5 Hrs 80% 2 Hrs 100%

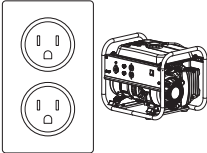

2

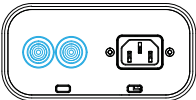

By Solar (800W of input):
3 hours to 80%, 4 hours to 100%

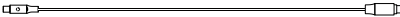

3 Hrs 80% 4 Hrs 100%

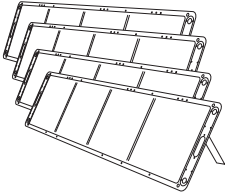

3

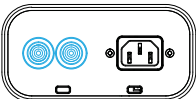

By Car Outlets (96W of input):
22.5 hours to 80%, 28.5 hours to 100%

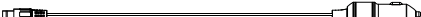

22.5 Hrs 80% 28.5 Hrs 100%

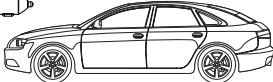

Display

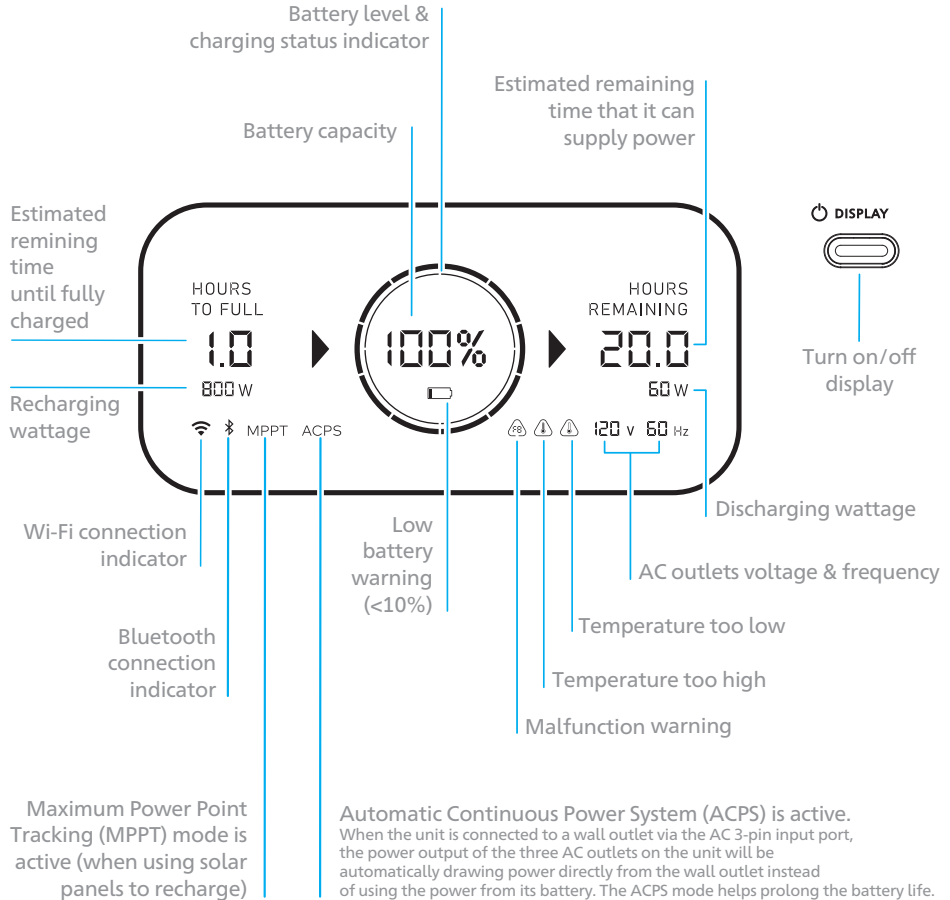

LED Light

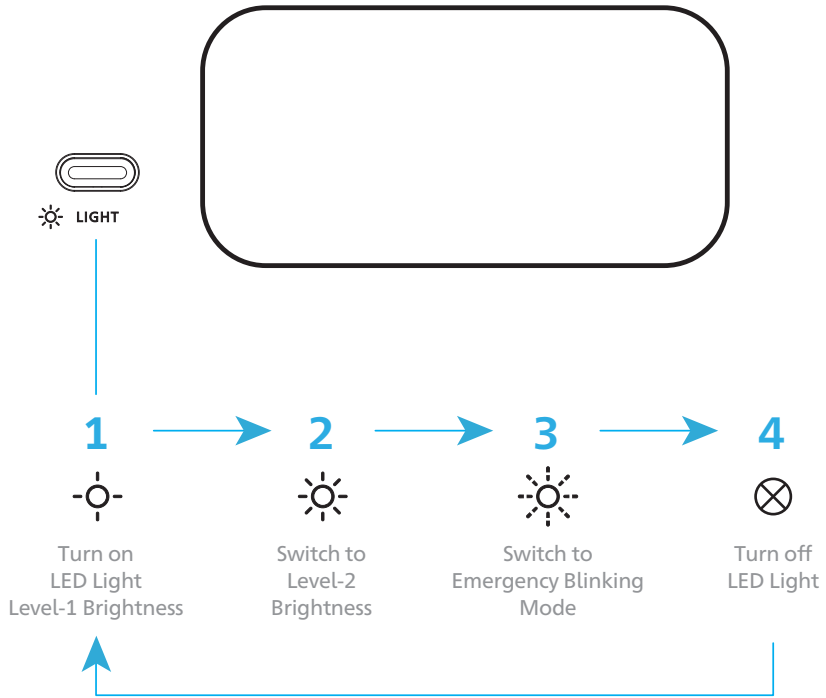

DC Power Output

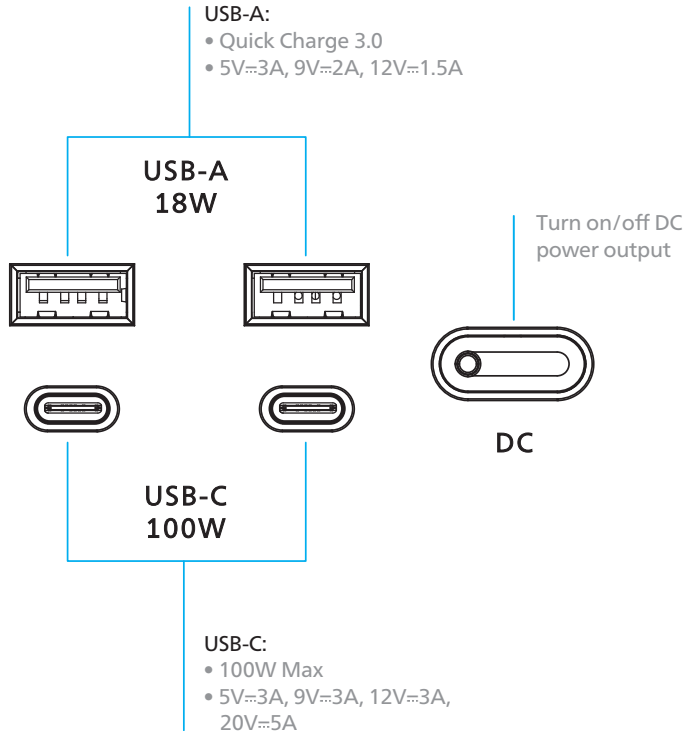

AC Power Output

Turn on/off AC power output



AC

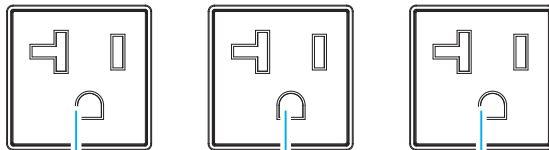







120V 2200W PURE SINE WAVE

AC Outlet:





- 120V~60Hz, 18.3A
- Continuous power: 2200 Watts
- Surge power: 4400 Watts
- Pure-Sine Wave Output

Estimated Usage Time







Home Appliances	Estimated Usage Time	Assumptions
 REFRIGERATOR / FREEZER	10-35 Hrs	60-200W
 MICROWAVE / OVEN	1-14 Days	500-1200W Use 3-10 times/day, each time 5-15 mins
 COFFEE MACHINE	1-7 Days	500-800W Use 3-10 times/day, each time 10 mins
 KETTLES	1-5 Days	800-1800W Use 3-10 times/day, each time 10 mins
 ELECTRIC FRY PAN	1-5 Days	800-1800W Use 3-6 times/day, each time 10-15 mins
 BLENDER	2-14 Days	300-850W Use 3-6 times/day, each time 5-10 mins

The chart above visualizes how you can best use your HOMEPower TWO PRO when facing a power outage. Each line explains the average wattage range of a supported home device, and how long the HOMEPower TWO PRO would be able to power that one device on a single charge, abiding by our assumed average usage times. Note, if you choose to power more than one device on a single charge of your HOMEPower TWO PRO, your battery supply will drain sooner than the noted estimated usage time frame.

Estimated Usage Time

Home Office	Estimated Usage Time	Assumptions
 CELLPHONES	>7 Days (~240 charges)	2-10W
 PC/DESKTOPS	2-14 Days	30-100W Use 1-8 hrs/day
 LAPTOPS	>7 Days (~20 charges)	30-100W Use 1-8 hrs/day
 TVS	2-14 Days	60-250W Use 1-6 hrs/day
 WI-FI / ROUTER / MODEM	>7 Days	5-20W Use 1-8 hrs/day
 CAMERA	>7 Days (~120 charges)	10W
Home Appliances	Estimated Usage Time	Assumptions
 LAMPS / LIGHTING	3-10 Days	5-100W Use 2-6 hrs/day

Estimated Usage Time

Home Appliances	Estimated Usage Time	Assumptions
 ELECTRIC GRILL	1-5 Days	800-1800W Use 3-6 times/day, each time 10-30 mins
 ELECTRIC PRESSURE COOKER / SLOW COOKER	1-5 Days	800-1200W Use 1-3 times/day, each time 30-60 mins
 AIR CONDITIONER	1-4 Days	500-2000W Use 1-5 times/day, each time 1-4 hours
 RADIANT HEATER	1-10 Days	800-1800W Use 1-5 times/day, each time 15-60 mins
 FANS	1-7 Days	50-100W Use 5-10 times/day, each time 1-4 hours
 HAIR DRYER	1-14 Days	800-1800W Use 1-3 times/day, each time 5-15 mins
 DISHWASHER	1-14 Days	200-600W Use 1-3 times/day, each time 30-60 mins

Estimated Usage Time

Medical Devices



CPAP MACHINE

Estimated Usage Time

3-14 Days

Assumptions

30-60W Use 4-8 hrs/day



OXYGEN CONCENTRATOR

3-8 Hrs

150-500W Use 1-5 times/day, each time 1-4 hours



BREAST PUMP

1-2 Weeks

20-50W Use 1-8 times/day, each time 15-30 mins

Tools



ELECTRIC DRILL

Estimated Usage Time

2-14 Days

Assumptions

500-900W Use 10-60 mins/day



ELECTRIC SAW

2-14 Days

800-1200W Use 10-60 mins/day



AIR COMPRESSOR

1-14 Days

800-2200W Use 10-60 mins/day



SUMP PUMP

1-10 Days

750-2000W Use 15-60 mins

Specifications

Battery

- Capacity: 2419.2Wh (63Ah/38.4V DC)
- Type: Lithium Iron Phosphate (LiFePO4)
- Cycle Life: ≥ 3000 cycles

Inputs

- AC 3-pin Port: 120V~60Hz, 12A
- 2X DC Charging Ports: 11.6V-54V \approx 10.5A, 400W max each (800W in total)
 - Solar Charge: Supports 17.5~54V \approx 10.5A 400 max each (21A, 800W max in total)
 - Car Charge: Supports 11.6~17.5V \approx 8A max each (16A max in total)
- Charge Controller: Built-in Maximum Power Point Tracking (MPPT)

Outputs

- 3X AC Outlets: 120V~60Hz, 18.3A, 2200W Rated, 4400W Surge Peak
- 2X PD100W USB-C: 5V \approx 3A, 9V \approx 3A, 12V \approx 3A, 15V \approx 3A, 20V \approx 5A, 100W max.
- 2X USB-A: Quick Charge 3.0, 5V \approx 3A, 9V \approx 2A, 12V \approx 1.5A, 18W max.

Safety Protection

- Over Charge Protection
- Over Discharge Protection
- Short Circuit Protection
- Over Current Protection
- Over Voltage Protection
- Over Temperature Protection

Dimension & Weight

- Dimension: L 17.83"x W 11.02"x H 14.11" (45.3 x 28 x 35.85 cm)
- Weight: 59.52 lbs (27.4 kg)

Temperature

- Operating Temperature (Charging): 32°F ~ 122°F (0°C ~ 50°C)
- Operating Temperature (Discharging): 10°F ~ 140°F (-12°C ~ 60°C)

Troubleshooting & FAQ

What devices can the HOMEPower TWO PRO charge or power?

The HOMEPower TWO PRO has multiple output ports including 2x USB-A, 2x USB-C, and 3x AC outlets.

It can charge and power crucial communication devices, home appliances, security devices, cameras, lighting, medical devices, tools, and more.

The USB-A and USB-C ports can charge common battery-powered devices charged by USB ports.

The AC outlets can charge and power devices that operate at less than 2200 Watts.

The total wattage output from the HOMEPower TWO PRO should be under 2200 Watts. If exceeded, the HOMEPower TWO PRO will shut off automatically.

Please check your device's specifications before use.

How long can the HOMEPower TWO PRO power up my device?

As a general rule of thumb, working time = capacity (Wh) X 0.85 / operating wattage of your device.

For example, if your device is 60W, with the HOMEPower TWO PRO, the working time will be about $2419\text{Wh} \times 0.85 / 60\text{W} = 34.2$ hrs

Please note: the actual working time may vary from different usages and conditions.

Can I charge my HOMEPower TWO PRO while supplying power to other devices at the same time?

Yes! The HOMEPower TWO PRO can be recharged while powering up and charging other devices.

Can the HOMEPower TWO PRO power the whole house?

Please note that the HOMEPower TWO PRO is designed to be a PORTABLE backup battery power station. It keeps your choice of home devices charged and operational for up to 7 days (depending on the power required by the individual device and the frequency of your using it). It's compatible with home appliances, electronic communication and medical devices, security systems, and more. You can conveniently take the HOMEPower TWO PRO to the area where your device is located, and plug your device into the unit. If your devices are located in different areas and you need to power them at the same time, you can either move all the devices to one area or buy multiple HOMEPower TWO PRO units for more backup power and flexibility.

Does the HOMEPower TWO PRO turn on automatically if the power goes out?

The HOMEPower TWO PRO is a portable power station. You will need to plug your device into the unit and turn on the unit after the power at your home goes out. It doesn't turn on automatically for safety reasons.

Can I use the HOMEPower TWO PRO indoors?

Yes, the HOMEPower TWO PRO can be used indoors. It doesn't emit any gas or harmful substances. It's 100% safe to be used indoors.

How long will the HOMEPower TWO PRO last?

The HOMEPower TWO PRO will hold its full charge for a minimum of one year. As best practice, we recommend using and recharging it every six months to keep the product in good condition. We expect our products to last for a long time and you don't need to change the battery inside.

Is the HOMEPower TWO PRO waterproof?

HOMEPower TWO PRO is NOT waterproof. Please do not store or use it in humid environments for long periods of time.

Safety Information

INSTRUCTIONS PERTAINING TO RISK OF FIRE, ELECTRIC SHOCK, OR INJURY TO PERSONS

IMPORTANT SAFETY INSTRUCTIONS

WARNING—When using the unit, the following basic precautions should always be adhered to:

- a) Read all the instructions before using the product.
- b) To reduce the risk of injury, close supervision is necessary when the product is used near children.
- c) Do not put fingers, hands, or other unrelated items into any opening of the product.
- d) Use of an attachment not recommended or sold by Geneverse may result in a risk of fire, electric shock, or injury to persons.
- e) To disconnect devices from the unit, pull from the plug, never the cord, in order to eliminate the risk of damage.
- f) Do not use a battery pack or appliance that is damaged or modified. Damaged or modified batteries may exhibit unpredictable behavior resulting in fire, explosion, or risk of injury.
- g) Do not operate the power pack with a damaged cord or plug, or a damaged output cable.
- h) Do not disassemble or attempt to make changes to the power pack. When service or repair is required, it should be conducted by a qualified service person. Incorrect reassembly may result in a risk of fire or electric shock.
- i) To reduce the risk of electric shock, unplug the power pack from the outlet before allowing service, repairs, or disassembly to occur.

j) PERSONAL SAFETY PRECAUTIONS

- 1) Keep plenty of fresh water and soap nearby when working with or near the battery, in case battery acid contacts skin or clothing.
- 2) Wear complete eye protection and clothing protection. Avoid touching eyes while working near battery.
- 3) If battery acid contacts skin or clothing, wash immediately with soap and water. If acid enters eye, immediately flood eye with running cold water for at least 10 minutes and seek further medical attention immediately.
- 4) NEVER smoke or allow a spark or flame in the vicinity of battery.
- 5) Be extra cautious to reduce risk of dropping a metal tool onto the battery. Impact to the battery may cause a spark, short-circuit, or other electrical explosion.
- k) When charging the internal battery, do not restrict ventilation in any way.
- l) Under abusive conditions, liquid may be ejected from the battery; avoid contact. If contact accidentally occurs, flush with water. If liquid contacts eyes, additionally seek medical help. Liquid ejected from the battery may cause irritation or burns.
- m) Do not expose a power pack to fire or excessive temperature. Exposure to fire or temperature above 265 °F / 130 °C may cause explosion.
- n) Have service performed by a qualified repair person using only identical replacement parts. This will ensure that the safety of the product is maintained.

SAVE THESE INSTRUCTIONS

OPERATING INSTRUCTIONS

- Use and store the unit only in a clean and dry environment. DO NOT use and store in dusty and wet environment.

- Check the unit prior to every use. DO NOT use the unit if it is damaged, broken.
- If rust, peculiar odors, overheating, or other abnormal circumstances are observed, stop using the unit immediately and contact the dealer or our customer service center.
- Make sure that the unit is properly secured when transporting it in a motor vehicle.
- Only charge, use, and store the unit within an ambient temperature of 32 – 104 °F (0 to 40 °C).
- Switch the unit off immediately if it has accidentally fallen, was dropped, or was exposed to vibrations.
- DO NOT use the unit if the power cord is damaged or broken.
- Keep the unit away from children. DO NOT let children use the power supply unit. Keep this product away from pets.
- DO NOT use the unit in an area or environment with high temperature.
- Should fluid from inside of the unit come in contact with your skin or clothing, wash the affected areas with tap water.
- In a storm, unplug the power cord from the socket.
- DO NOT charge the unit via power supply systems that operate outside of 100-240V.
- DO NOT place the unit on its side or upside down while in use or storage.
- DO NOT use accessories for other usage.
- Make sure that the device you are connecting is switched off before you connect it.
- DO NOT expose a power pack to fire or excessive temperature. Exposure to fire or temperature above 265 °F / 130 °C may cause explosion.
- Solar charge times depend on weather conditions. Place your solar panel where it will get as much direct sunlight as possible.
- DO NOT place the power pack on the floor, or at a height less than 457 mm (18 inches) above the floor, during use in a repair facility.

Warning: Do not remove the battery pack without permission. If you need to repair the battery pack, contact your local manufacturer as soon as possible.

DANGER: This device is intended to be used indoors only. Do not use outdoors under any conditions.

MOVING AND STORAGE INSTRUCTIONS

- DO NOT move the unit if it is recharging or in use.
- DO NOT dispose of the unit together with household waste.
- DO NOT place the unit close to or in a fire or expose it to heat. Keep out of direct sunlight.
- DO NOT store the unit in a bathroom or in an area exposed to rain or moisture.
- DO NOT disassemble the power pack. Take it to a qualified service person when service or repair is required. Incorrect reassembly may result in a risk of fire or electric shock.
- DO NOT store the unit in an area or environment with high temperature.

USER MAINTENANCE INSTRUCTIONS

- Before using or storing, plug your unit into the wall until it is fully charged. If you see the LCD battery is low at any point, plug it into a power source, like an AC outlet or a solar panel as soon as possible.
- To preserve the battery lifespan, please use and recharge at least once every 6 months.

Support

If you experience any problems with your Geneverse product(s), please contact our support team at geneverse.com/support or email us at support@geneverse.com or call us at 1 (800) 210-8665

Website: www.geneverse.com

Download the Geneverse Mobile App



This device complies with part 15 of the FCC Rules. Operation is subject to the following two conditions:

- (1) This device may not cause harmful interference.
- (2) This device must accept any interference received, including interference that may cause undesired operation.

For class B digital device:

NOTE: This equipment has been tested and found to comply with the limits for a Class B digital device, pursuant to part 15 of the FCC Rules. These limits are designed to provide reasonable protection against harmful interference in a residential installation. This equipment generates, uses and can radiate radio frequency energy and, if not installed and used in accordance with the instructions, may cause harmful interference to radio communications. However, there is no guarantee that interference will not occur in a particular installation. If this equipment does cause harmful interference to radio or television reception, which can be determined by turning the equipment off and on, the user is encouraged to try to correct the interference by one or more of the following measures:

- Reorient or relocate the receiving antenna.
- Increase the separation between the equipment and receiver.
- Connect the equipment into an outlet on a circuit different from that to which the receiver is connected.
- Consult the dealer or an experienced radio/TV technician for help.

MODIFICATION: Any changes or modifications not expressly approved by the grantee of this device could void the user's authority to operate the device.



WARNING: Cancer and Reproductive Harm - www.P65Warnings.ca.gov

© Copyright 2020-2022 Geneverse Energy Inc.
All trademarks cited herein are the property of their respective owners.

The information contained herein is subject to change without notice. The only warranties for Geneverse products and services are set forth in the warranty statements accompanying such products and services. Geneverse shall not be liable for technical or editorial errors or omissions contained herein.

Edition: GEV-UM-HP2Pro