

## Gen IV-V Underdrive Pulley Installation

Access the pulley from above or below.

If from above – remove the airbox.

If from below remove the front belly pan.

### REMOVAL

1. Remove the air cleaner housing ([Refer to 09 - Engine/Air Intake System/BODY. Air Cleaner - Removal](#)).
2. Release the belt tension by rotating the accessory drive belt tensioner (7) **counterclockwise** with a 15 mm wrench on the tensioner pulley bolt. Rotate belt tensioner until belt can be removed from pulleys.
3. Remove belt.
4. Gently release accessory drive belt tensioner (7).

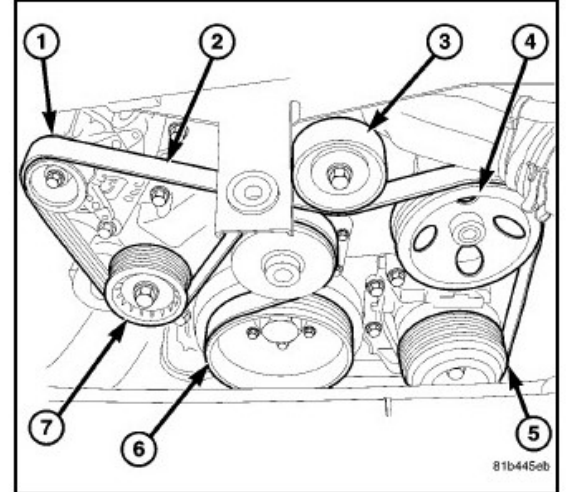

C. Remove the six 13mm oem bolts that hold the pulley on to the damper.

D. Install the new pulley with the new bolts; torque the bolts to 20 ft lbs and use Loctite blue.

Re-install the OEM belt as follows:

### Idler Pulley Installation

Remove OEM pulley and replace, tighten to 40 ft lbs using the included longer bolt.

### Tensioner Pulley Installation

Remove OEM pulley and replace, tighten to 30 ft lbs using the included longer bolt. *Note – this is a left-hand threaded bolt.*

# INSTALLATION

**NOTE:** When installing accessory drive belt onto pulleys, make sure that belt is properly routed and all V-grooves make proper contact with pulleys.

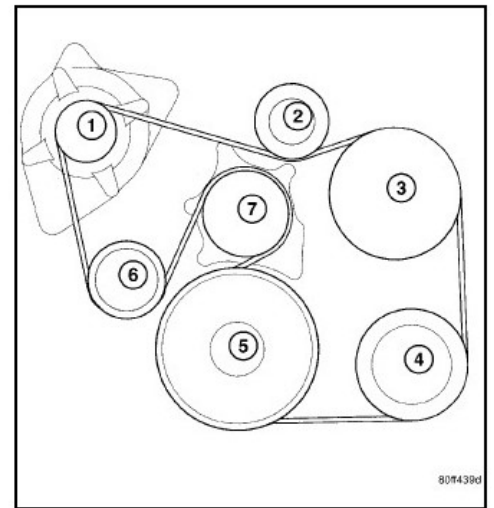

## Accessory Drive Belt Routing

- 1 - GENERATOR
- 2 - IDLER PULLEY
- 3 - POWER STEERING PUMP
- 4 - A/C COMPRESSOR
- 5 - CRANKSHAFT
- 6 - BELT TENSIONER
- 7 - WATER PUMP

1. Position the drive belt over all pulleys except for the water pump pulley.
2. Rotate tensioner counterclockwise and slip the belt over the water pump pulley.
3. Gently release tensioner.
4. Install the air cleaner housing ([Refer to 09 - Engine/Air Intake System/BODY, Air Cleaner - Installation](#)).

