



Overview:

The seat brackets provide a bolt in solution for use with Tillett Racing seats, specifically the B6/B7, B6/B7 XL, B5, and B1 seats. The brackets provide a mounting foundation for seat mounting with the use of the Tillett TBF1 (B6/B7), TB2 / TB3 (B5), and TB1 (B1) brackets.

In addition to seat mounting directly to the bracket (for the most headroom), a spacer can be used to return to factory height along with a slider for adjustability (not recommended for track use).

The brackets also serve as a mounting point for a 6 point harness sub and lap belts, the factory seat belt buckle, factory wiring harness, along with the occupancy emulator (passenger side only).

Compatibility:

These parts will fit any 2013-2017 Viper.

Construction:

The brackets are manufactured from type III hard anodized .250" aluminum with 12.9 grade hardware for maximum strength.

Installation hardware and side seat spacers are included with the kit.

Weight:

Weight savings for the Tillett seat installations depending on seat and options will be 26-37 lbs per side from the factory setup assuming OEM harness and buckle transfer. This includes additional weight of the harness eyebolts.

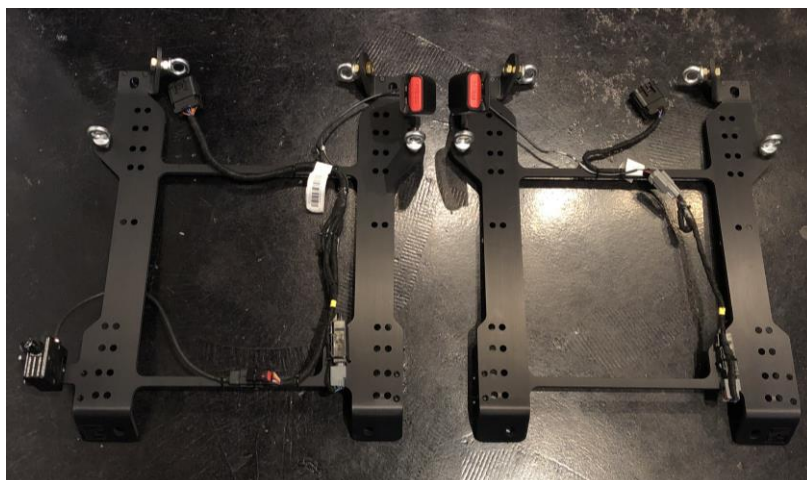

Passenger and Driver Side Seat Brackets with OEM Harness Installed



B7 Seat Installed with Racing Harness

Ordering Information:

<http://www.dougshelbyengineering.com/tillett.html>

DSE-VP-SB-001 Driver Side Gen V Dodge Viper Floor Brackets with Lap and Sub Belt Attachments and Hardware

DSE-VP-SB-002 Passenger Side Gen V Dodge Viper Floor Brackets with Lap and Sub Belt Attachments and Hardware

DSE-VP-SB-007 Gen III-V Dodge Viper 1-1/8" Spacers (pair) - Returns to OEM Seat Height, Allows Full Forward Mounting

DSE-VP-OE-001: 2013-2017 Gen V Dodge Viper Passenger Occupant Emulator

DSE-VP-SB-008 Aluminum Seat Side Bracket Finishing Washers

Installation Guide:

Seat Removal –

- It may be helpful to note the relative seat position on the slider before removing the seat to reduce fit trial and error time later.
- Tape off lower trim pieces to protect them from damage during seat removal.
- Once unbolted the seat can be removed by leaning the top inward toward the center of the car and lifting the bottom of the seat. Adjust the recline for easier removal and center fore/aft on the slider.
- Do not power the car with the seats removed to avoid codes being set.

1. Before proceeding with the following repair procedure, review all warnings and cautions, ([Refer to 23 - Body/Seats - Warning](#)).
2. Open deck lid.
3. Position the seat to access the front and rear fasteners.
4. Disconnect and isolate the battery negative cable.

WARNING: Wait two minutes for the system reserve capacitor to discharge before servicing any airbag components. Failure to do this may result in serious or fatal injury.

5. Remove the bolts (2) from the front of the seat (1).

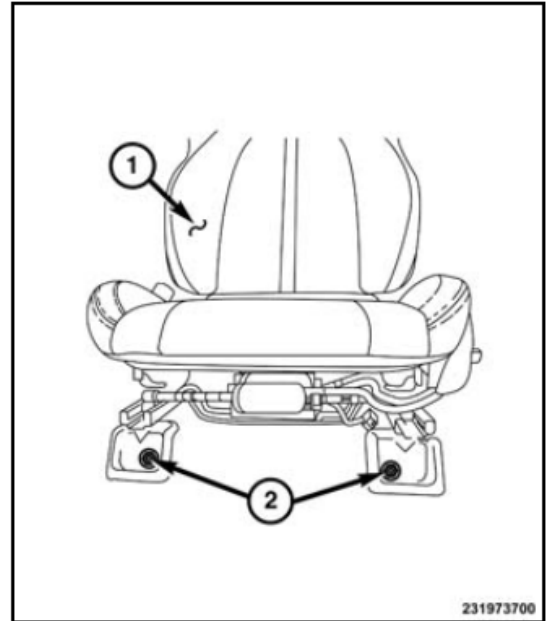

6. Remove the nuts (3) from the rear of the seat (1).
7. Disconnect the seat electrical connector (2) located at the rear underside of seat cushion.
8. Remove seat from vehicle.

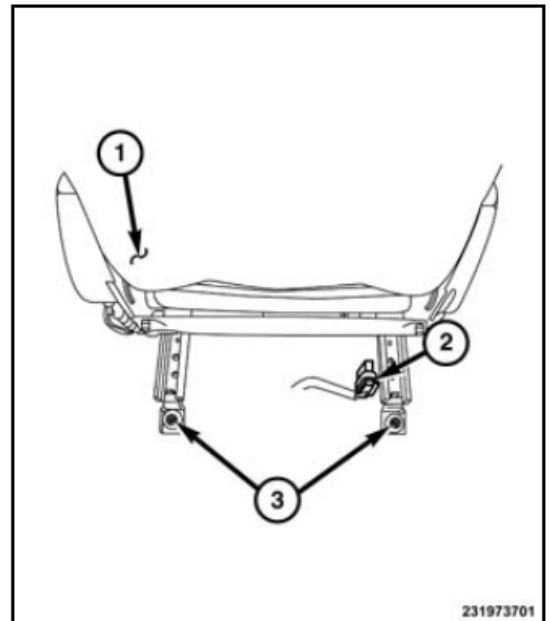

Warning: Only use Class 12.9 or Grade 8 bolts with seat hardware for maximum strength and safety.

- **Bracket Setup**

- If desired, remove the OEM wiring harness and seat belt buckle from the OEM seat. This will prevent codes (driver side) and allow the use of the OEM seat belt buckle. For the passenger side an occupant emulator (available separately) will eliminate codes and allow for the control of the passenger airbag.
- Install the harness and buckle on the seat bracket.
 - Install the buckle using the OEM wavy washer and included hardware.
 - Tighten the nut using Loctite so that there is resistance in the buckle but it is still able to rotate.
 - Note: the seat belt buckle may need to be bent slightly outward after installation to fit the specific seat and setup.
 - Install the wiring with tywraps onto the bracket. Keep all wiring clear of seat hardware and be mindful of sub belt routing to reduce the risk of damage.
 - (optional) Install the passenger occupancy emulator onto the passenger side bracket using loctite and connect to the appropriate connector on the OEM harness.
 - *Note: for full forward position the seat belt track position sensor should be mounted with the steel trigger between the mounting surface and the sensor.*

- **Seat Setup**

- Install the Tillett seat onto the bracket outside of the car. Installation will vary depending on the seat, options and desired incline and position. In general:
 - If you observed seat position on the slider prior to removal from the car you can use this as a starting point for seat position on the bracket.
 - The outer set of holes are to be used for the B6XL / B7XL seats, the inner holes for the B1, B5, and B6/B7 seats.
 - Pick a hard mount point of the 5 available. The full forward position is achieved from using the mid hole and forward hole in conjunction with the spacer. *Full forward requires the seat position sensor trigger mentioned in the note above.*
 - If height spacers are desired, install these first onto the bracket using the flat head hardware.
 - If a slider is desired install either directly to the bracket or on the seat spacer. *Slider will need to be spaced off of the bracket with washers to allow clearance for the lever.*
 - Install the Tillett seat brackets on the bracket, seat spacer or slider. Leave hardware somewhat loose for in/out adjustment.
 - Pick a seat height and incline position as a starting point. Note the various plastic spacers included in the kit are meant to fill the gap between the Tillett bracket and side of the seat. These gaps will vary with seat height and position. 2 longer 30mm socket cap screws are included to ensure enough thread (min 10mm) in the seat for thicker spacing. *Minimize spacer us as much as possible.*
 - Install the forward carpet spacers. Note these may need to be removed later if they block the bolts being used.
 - With everything adjusted as desired, preliminarily tighten the hardware down and place the seat in the car for a test fit.
 - Note adjustments that may be required (fore/aft/incline).
 - Repeat adjustment steps above and test fit until desired setup is achieved.
 - *With desired setup achieved note clearances in the car for the rearward studs and nuts. This will determine if the seat assembly can be fully installed prior to installation in the car or if the seat bracket will need to be installed in the car before installing the seat.*
 - Confirm seat belt buckle clears seat and enables latching while in the car.
 - Remove the seat from the car one final time.
 - Remove each bolt and apply Loctite and tighten the M8 hardware to 27 ft-lb (37 NM).
 - Install the forward carpet spacers using Loctite.
 - Assemble as necessary for in car installation.
 - Before final installation, connect the electrical connectors and battery and power the car (ignition position) to confirm no codes are set and operation of the optional occupancy emulator.

1. Before proceeding with the following repair procedure, review all warnings and cautions, ([Refer to 23 - Body/Seats - Warning](#)).
2. Place the seat assembly in the vehicle.
3. Loosely install the front seat attaching bolts and nuts.

NOTE: The front BOLTS must be torqued to the specified torque prior to the rear NUTS being secured.

4. Tighten inboard front seat front bolt to 43 N·m (32 ft. lbs.) torque.
5. Tighten outboard front seat front bolt to 43 N·m (32 ft. lbs.) torque.

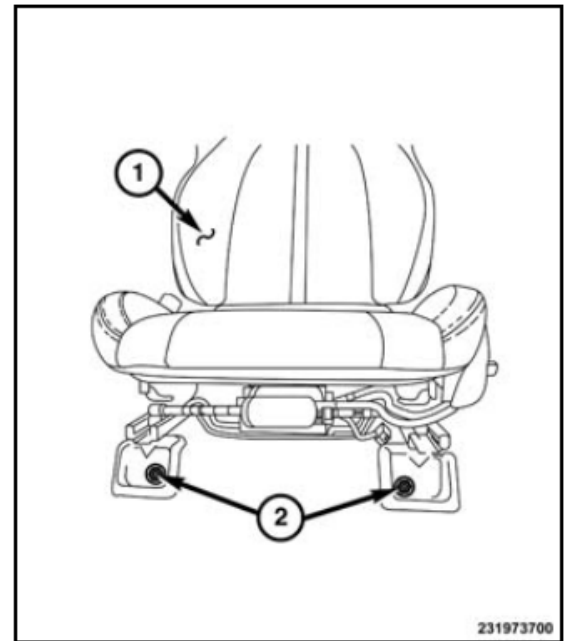

6. Tighten the inboard rear nut to 37 N·m (27 ft. lbs.) torque.
7. Tighten the outboard rear nut to 37 N·m (27 ft. lbs.) torque.
8. Connect the electrical connector (2).

WARNING: Do not connect the battery negative cable . Serious or fatal injury may result if the system test is not performed first.

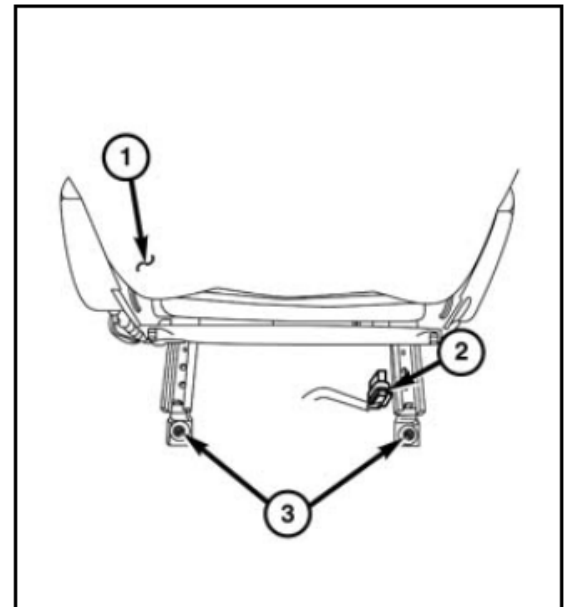

9. Perform supplemental restraint system test, ([Refer to 10 - Restraints/Diagnosis and Testing](#)).
10. Place battery access cover into place and install four bolts.
11. Close deck lid.

Note for B6/B7 Seats: To use the OEM lap belt the belt will need to be run through the outboard seat belt holes.

- Remove the seat belt anchor bolt.
- Route the seat belt through the outer side of the B6/B7 seat.
- Apply Loctite and tighten the screw to 40 N·m (30 ft. lbs.).

Inspection and Maintenance:

- Periodically inspect the bracket and hardware to ensure nothing is loose or damaged.

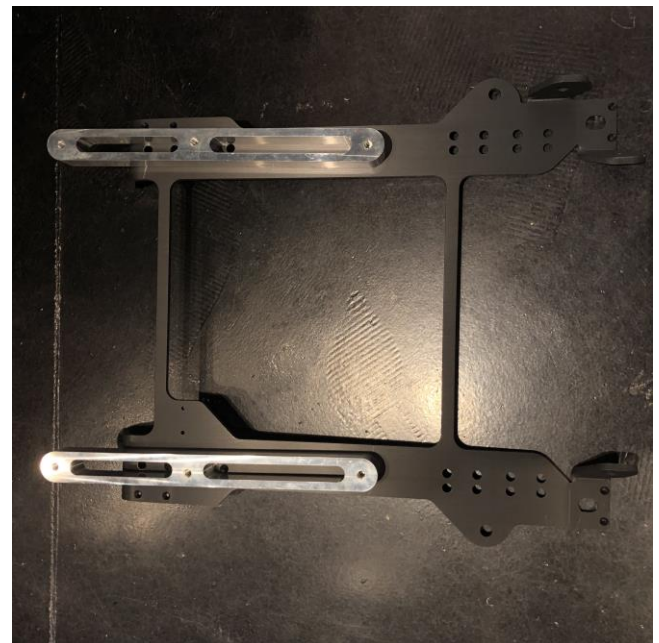

Spacers Installed in Far Forward Position

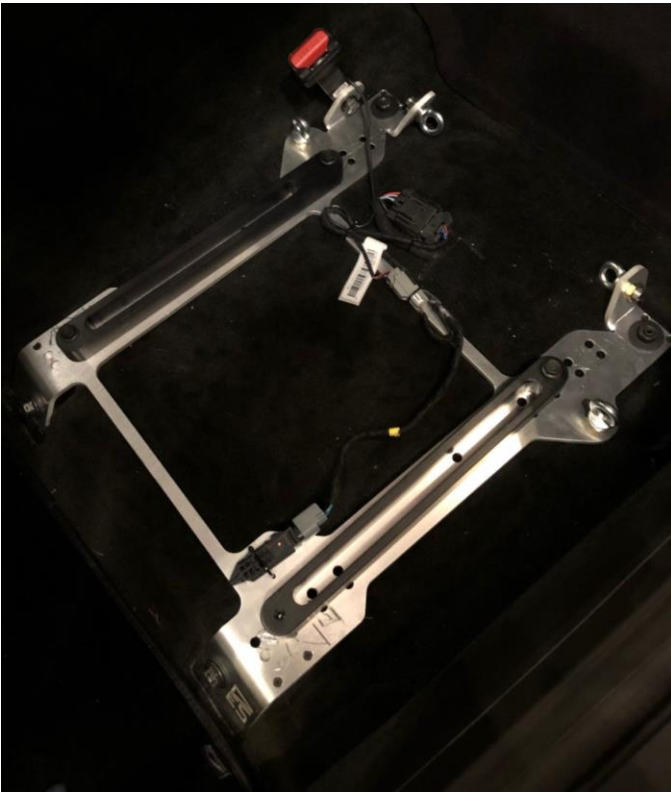

Bracket installed with Optional Seat Spacers

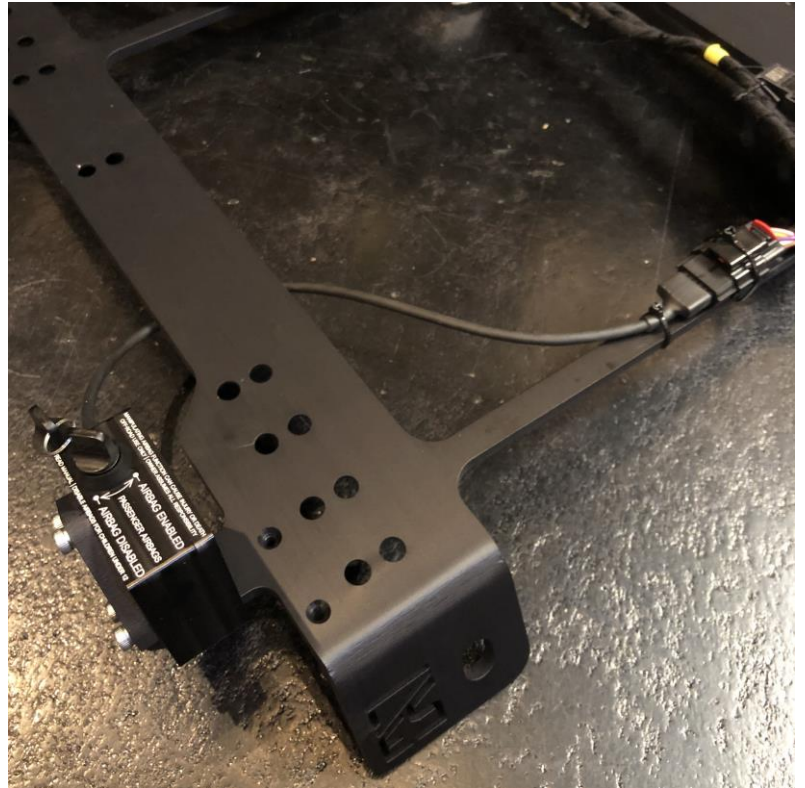

Occupancy Emulator Installed on Passenger Side Bracket

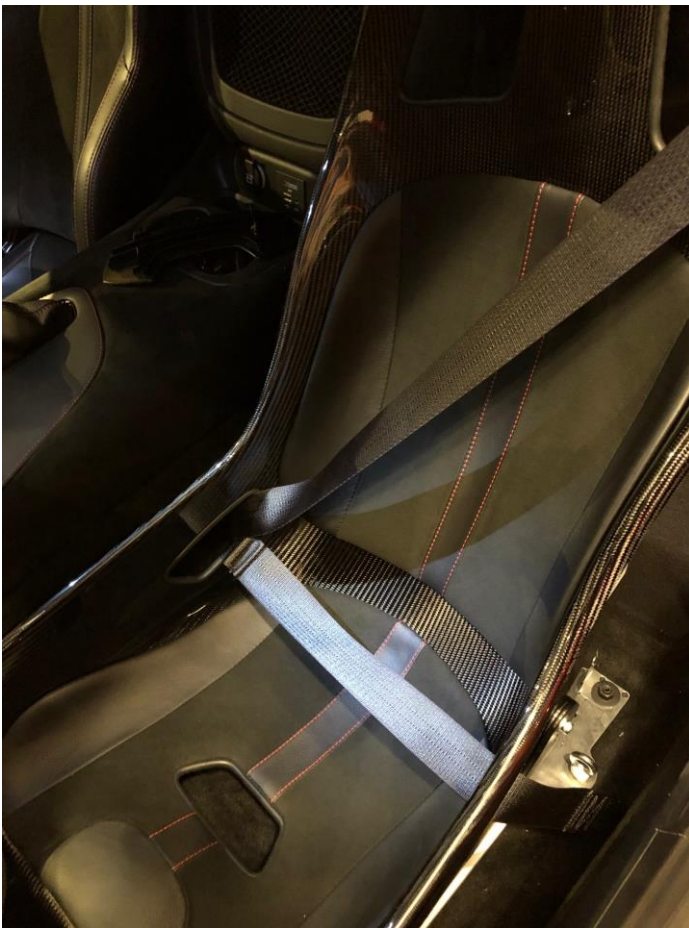

B7 Seat Installed with OEM Lap Belt Routed Through Seat

Thank you for your purchase!

Your business is appreciated and customer satisfaction is our top priority! Don't hesitate to contact us via email with any questions or feedback. Word of mouth is the best form of advertising so if you are satisfied please spread the word!

Disclaimer of Liability:

Doug Shelby Engineering assumes no liability expressed or implied for the improper installation or use of this product or its components. Doug Shelby Engineering is NOT responsible for any damage, consequential or otherwise for equipment failure after installation.

Vehicle Modification:

Modification of your vehicle with the parts identified above may alter its stock performance; the buyer hereby expressly assumes all risks associated with any such modification.

Disclaimer of Warranty:

Seller disclaims any warranty express or implied with respect to the parts sold hereby whether as to merchantability, fitness for particular purpose, or any other matter.